

CD54HC4538, CD74HC4538, CD54HCT4538, CD74HCT4538

High-Speed CMOS Logic Dual Retriggerable Precision Monostable Multivibrator

Features

- Retriggerable/Resettable Capability
- Trigger and Reset Propagation Delays Independent of R_X , C_X
- Triggering from the Leading or Trailing Edge
- Q and \bar{Q} Buffered Outputs Available
- Separate Resets
- Wide Range of Output Pulse Widths
- Schmitt Trigger Input on A and \bar{B} Inputs
- Retrigger Time is Independent of C_X
- Fanout (Over Temperature Range)
 - Standard Outputs 10 LSTTL Loads
 - Bus Driver Outputs 15 LSTTL Loads
- Wide Operating Temperature Range . . . -55°C to 125°C
- Balanced Propagation Delay and Transition Times
- Significant Power Reduction Compared to LSTTL Logic ICs
- HC Types
 - 2V to 6V Operation
 - High Noise Immunity: $N_{IL} = 30\%$, $N_{IH} = 30\%$ of V_{CC} at $V_{CC} = 5V$
- HCT Types
 - 4.5V to 5.5V Operation
 - Direct LSTTL Input Logic Compatibility, $V_{IL} = 0.8V$ (Max), $V_{IH} = 2V$ (Min)
 - CMOS Input Compatibility, $I_I \leq 1\mu A$ at V_{OL} , V_{OH}

Pinout

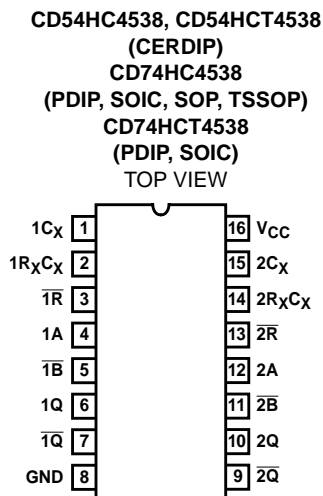

Description

The 'HC4538 and 'HCT4538 are dual retriggerable/resettable monostable precision multivibrators for fixed voltage timing applications. An external resistor (R_X) and an external capacitor (C_X) control the timing and the accuracy for the circuit. Adjustment of R_X and C_X provides a wide range of output pulse widths from the Q and \bar{Q} terminals. The propagation delay from trigger input-to-output transition and the propagation delay from reset input-to-output transition are independent of R_X and C_X .

Leading-edge triggering (A) and trailing edge triggering (\bar{B}) inputs are provided for triggering from either edge of the input pulse. An unused "A" input should be tied to GND and an unused \bar{B} should be tied to V_{CC} . On power up the IC is reset. Unused resets and sections must be terminated. In normal operation the circuit retriggers on the application of each new trigger pulse. To operate in the non-triggerable mode \bar{Q} is connected to \bar{B} when leading edge triggering (A) is used or Q is connected to A when trailing edge triggering (\bar{B}) is used. The period (τ) can be calculated from $\tau = (0.7) R_X C_X$; R_{MIN} is 5k Ω . C_{MIN} is 0pF.

Ordering Information

PART NUMBER	TEMP. RANGE (°C)	PACKAGE
CD54HC4538F3A	-55 to 125	16 Ld CERDIP
CD54HCT4538F3A	-55 to 125	16 Ld CERDIP
CD74HC4538E	-55 to 125	16 Ld PDIP
CD74HC4538M	-55 to 125	16 Ld SOIC
CD74HC4538MT	-55 to 125	16 Ld SOIC
CD74HC4538M96	-55 to 125	16 Ld SOIC
CD74HC4538NSR	-55 to 125	16 Ld SOP
CD74HC4538PW	-55 to 125	16 Ld TSSOP
CD74HC4538PWR	-55 to 125	16 Ld TSSOP
CD74HC4538PWT	-55 to 125	16 Ld TSSOP
CD74HCT4538E	-55 to 125	16 Ld PDIP
CD74HCT4538M	-55 to 125	16 Ld SOIC
CD74HCT4538MT	-55 to 125	16 Ld SOIC
CD74HCT4538M96	-55 to 125	16 Ld SOIC

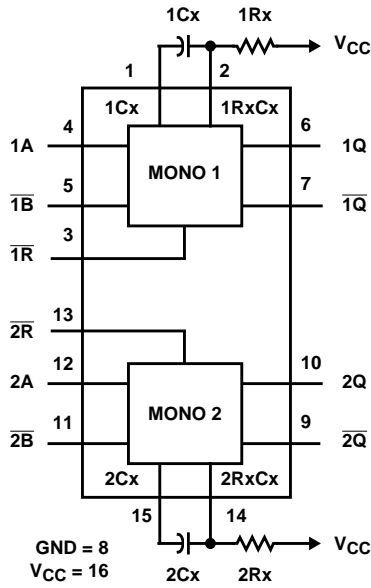

NOTE: When ordering, use the entire part number. The suffixes 96 and R denote tape and reel. The suffix T denotes a small-quantity reel of 250.

Functional Diagram



TRUTH TABLE

INPUTS			OUTPUTS	
\bar{R}	A	\bar{B}	Q	\bar{Q}
L	X	X	L	H
X	H	X	L	H
X	X	L	L	H
H	L	↓	One High Level Pulse	One Low Level Pulse
H	↑	H	One High Level Pulse	One Low Level Pulse

H = High Level, L = Low Level, ↑ = Transition from Low to High,
 ↓ = Transition from High to Low,  One High Level Pulse,
 One Low Level Pulse, X = Irrelevant.

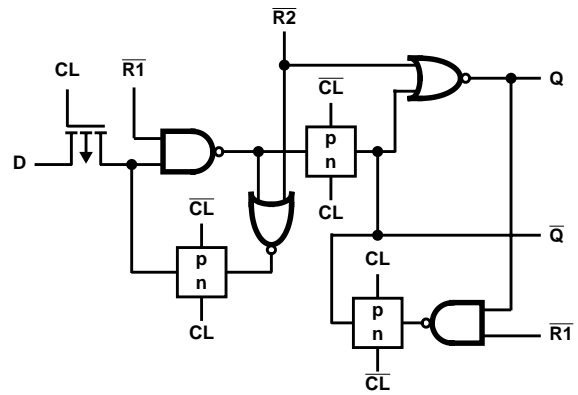

FIGURE 1. FF DETAIL

CD54HC4538, CD74HC4538, CD54HCT4538, CD74HCT4538

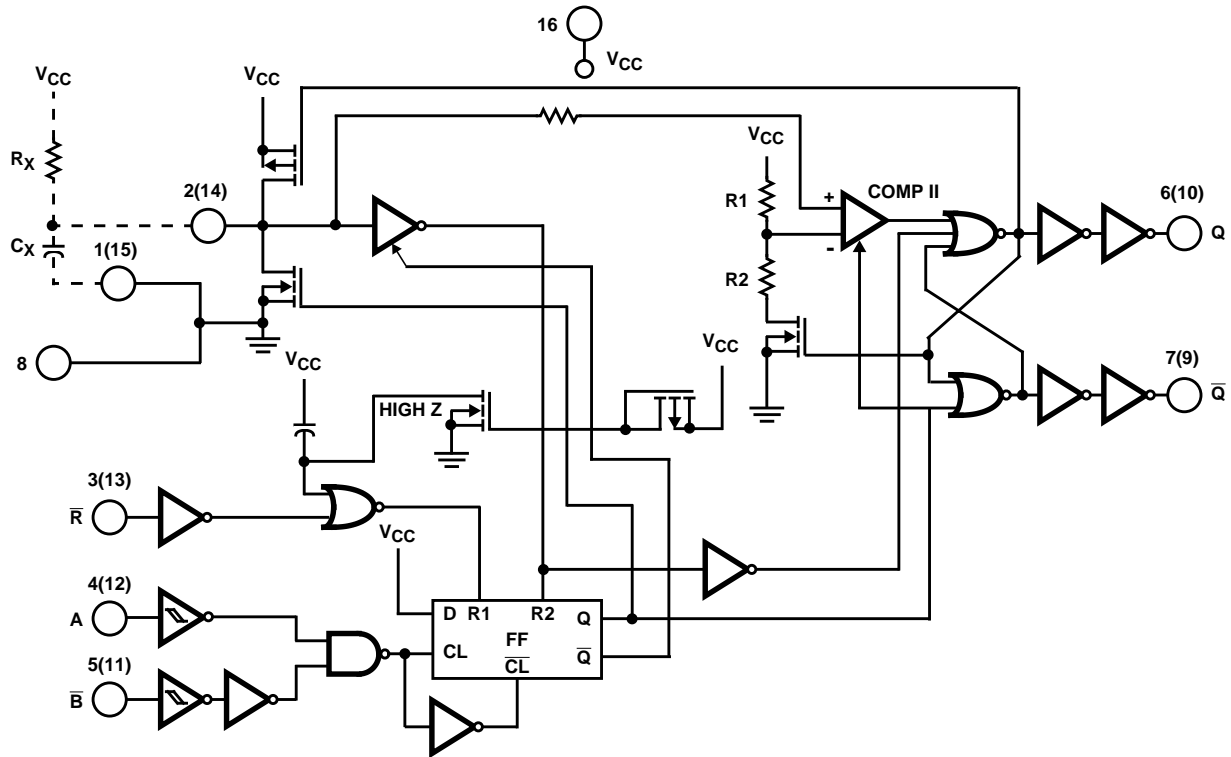

FIGURE 2. LOGIC DIAGRAM (1 MONO)

FUNCTIONAL TERMINAL CONNECTIONS

FUNCTION	V _{CC} TO TERMINAL NUMBER		GND TO TERMINAL NUMBER		INPUT PULSE TO TERMINAL NUMBER		OTHER CONNECTIONS	
	MONO ₁	MONO ₂	MONO ₁	MONO ₂	MONO ₁	MONO ₂	MONO ₁	MONO ₂
Leading-Edge Trigger/Retriggerable	3, 5	11, 13			4	12		
Leading-Edge Trigger/Non-Retriggerable	3	13			4	12	5-7	11-9
Trailing-Edge Trigger/Retriggerable	3	13	4	12	5	11		
Trailing-Edge Trigger/Non-Retriggerable	3	13			5	11	4-6	12-10

NOTES:

1. A retriggerable one-shot multivibrator has an output pulse width which is extended one full time period (T) after application of the last trigger pulse.
2. A non-triggerable one-shot multivibrator has a time period (T) referenced from the application of the first trigger pulse.



FIGURE 3. INPUT PULSE TRAIN

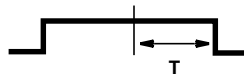

FIGURE 4. RETRIGGERABLE MODE PULSE WIDTH (A MODE)

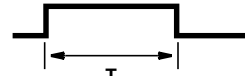

FIGURE 5. NON-RETRIGGERABLE MODE PULSE WIDTH (A MODE)

CD54HC4538, CD74HC4538, CD54HCT4538, CD74HCT4538

Absolute Maximum Ratings

DC Supply Voltage, V_{CC}	-0.5V to 7V
DC Input Diode Current, I_{IK}	
For $V_I < -0.5V$ or $V_I > V_{CC} + 0.5V$	$\pm 20mA$
DC Output Diode Current, I_{OK}	
For $V_O < -0.5V$ or $V_O > V_{CC} + 0.5V$	$\pm 20mA$
DC Output Source or Sink Current per Output Pin, I_O	
For $V_O > -0.5V$ or $V_O < V_{CC} + 0.5V$	$\pm 25mA$
DC V_{CC} or Ground Current, I_{CC}	$\pm 50mA$

Operating Conditions

Temperature Range, T_A	-55°C to 125°C
Supply Voltage Range, V_{CC} (Note 3)	
HC Types2V to 6V
HCT Types	4.5V to 5.5V
DC Input or Output Voltage, V_I, V_O	0V to V_{CC}
Input Rise and Fall Times, t_r, t_f	
Reset Input:	
2V	1000ns (Max)
4.5V	500ns (Max)
6V	400ns (Max)
Trigger Inputs A or B:	
2V	Unlimited (Max)
4.5V	Unlimited (Max)
6V	Unlimited (Max)
External Timing Resistor, R_X (Note 4)	5k Ω (Min)
External Timing Capacitor, C_X (Note 4)	0 (Min)

CAUTION: Stresses above those listed in "Absolute Maximum Ratings" may cause permanent damage to the device. This is a stress only rating and operation of the device at these or any other conditions above those indicated in the operational sections of this specification is not implied.

NOTES:

3. Unless otherwise specified, all voltages are referenced to ground.
4. The maximum allowable values of R_X and C_X are a function of leakage of capacitor C_X , the leakage of the 'HC4538, and leakage due to board layout and surface resistance. Values of R_X and C_X should be chosen so that the maximum current into pin 2 or pin 14 is 30mA. Susceptibility to externally induced noise signals may occur for $R_X > 1M\Omega$.
5. The package thermal impedance is calculated in accordance with JESD 51-7.

DC Electrical Specifications

PARAMETER	SYMBOL	TEST CONDITIONS		V_{CC} (V)	25°C			-40°C TO 85°C		-55°C TO 125°C		UNITS	
		V_I (V)	I_O (mA)		MIN	TYP	MAX	MIN	MAX	MIN	MAX		
HC TYPES													
High Level Input Voltage	V_{IH}	-	-	2	1.5	-	-	1.5	-	1.5	-	V	
				4.5	3.15	-	-	3.15	-	3.15	-	V	
				6	4.2	-	-	4.2	-	4.2	-	V	
Low Level Input Voltage	V_{IL}	-	-	2	-	-	0.5	-	0.5	-	0.5	V	
				4.5	-	-	1.35	-	1.35	-	1.35	V	
				6	-	-	1.8	-	1.8	-	1.8	V	
High Level Output Voltage CMOS Loads	V_{OH}	V_{IH} or V_{IL}	-0.02	2	1.9	-	-	1.9	-	1.9	-	V	
				4.5	4.4	-	-	4.4	-	4.4	-	V	
				6	5.9	-	-	5.9	-	5.9	-	V	
High Level Output Voltage TTL Loads	V_{OH}	V_{IH} or V_{IL}	-	-	-	-	-	-	-	-	-	V	
				-4	4.5	3.98	-	-	3.84	-	3.7	-	V
				-5.2	6	5.48	-	-	5.34	-	5.2	-	V

CD54HC4538, CD74HC4538, CD54HCT4538, CD74HCT4538

DC Electrical Specifications (Continued)

PARAMETER	SYMBOL	TEST CONDITIONS		V _{CC} (V)	25°C			-40°C TO 85°C		-55°C TO 125°C		UNITS
		V _I (V)	I _O (mA)		MIN	TYP	MAX	MIN	MAX	MIN	MAX	
Low Level Output Voltage CMOS Loads	V _{OL}	V _{IH} or V _{IL}	0.02	2	-	-	0.1	-	0.1	-	0.1	V
			0.02	4.5	-	-	0.1	-	0.1	-	0.1	V
			0.02	6	-	-	0.1	-	0.1	-	0.1	V
Low Level Output Voltage TTL Loads	V _{OL}	V _{IH} or V _{IL}	-	-	-	-	-	-	-	-	-	V
			4	4.5	-	-	0.26	-	0.33	-	0.4	V
			5.2	6	-	-	0.26	-	0.33	-	0.4	V
Input Leakage Current A, B, R	I _I	V _{CC} or GND	-	6	-	-	±0.1	-	±1	-	±1	µA
Input Leakage Current R _X C _X (Note 6)			-	6	-	-	±0.05	-	±0.5	-	±0.5	µA
Quiescent Device Current	I _{CC}	V _{CC} or GND	0	6	-	-	8	-	80	-	160	µA
Active Device Current Q = High & Pins 2, 14 at V _{CC} /4	I _{CC}	V _{CC} or GND	0	6	-	-	0.6	-	0.8	-	1	mA
HCT TYPES												
High Level Input Voltage	V _{IH}	-	-	4.5 to 5.5	2	-	-	2	-	2	-	V
Low Level Input Voltage	V _{IL}	-	-	4.5 to 5.5	-	-	0.8	-	0.8	-	0.8	V
High Level Output Voltage CMOS Loads	V _{OH}	V _{IH} or V _{IL}	-0.02	4.5	4.4	-	-	4.4	-	4.4	-	V
			-4	4.5	3.98	-	-	3.84	-	3.7	-	V
Low Level Output Voltage CMOS Loads	V _{OL}	V _{IH} or V _{IL}	0.02	4.5	-	-	0.1	-	0.1	-	0.1	V
			4	4.5	-	-	0.26	-	0.33	-	0.4	V
Low Level Output Voltage TTL Loads	V _{OL}	V _{IH} or V _{IL}	-	-	-	-	-	-	-	-	-	V
			4	4.5	-	-	0.26	-	0.33	-	0.4	V
Input Leakage Current	I _I	V _{CC} and GND	-	5.5	-	-	±0.1	-	±1	-	±1	µA
Input Leakage Current R _X C _X (Note 6)			-	5.5	-	-	±0.05	-	±0.5	-	±0.5	µA
Quiescent Device Current	I _{CC}	V _{CC} or GND	0	5.5	-	-	8	-	80	-	160	µA
Active Device Current Q = High & Pins 2, 14 at V _{CC} /4	I _{CC}	V _{CC} or GND	0	5.5	-	-	0.6	-	0.8	-	1	mA
Additional Quiescent Device Current Per Input Pin: 1 Unit Load	ΔI _{CC} (Note 7)	V _{CC} -2.1	-	4.5 to 5.5	-	100	360	-	450	-	490	µA

NOTES:

- When testing I_{IL} the Q output must be high. If Q is low (device not triggered) the pull-up P device will be ON and the low resistance path from V_{DD} to the test pin will cause a current far exceeding the specification.
- For dual-supply systems theoretical worst case (V_I = 2.4V, V_{CC} = 5.5V) specification is 1.8mA.

CD54HC4538, CD74HC4538, CD54HCT4538, CD74HCT4538

HCT Input Loading Table

INPUT	UNIT LOADS
All	0.5

NOTE: Unit Load is ΔI_{CC} limit specified in DC Electrical Table, e.g. 360 μ A max at 25°C.

Prerequisite for Switching Specifications

PARAMETER	SYMBOL	V_{CC} (V)	25°C			-40°C TO 85°C			-55°C TO 125°C			UNITS
			MIN	TYP	MAX	MIN	TYP	MAX	MIN	TYP	MAX	
HC TYPES												
Input Pulse Widths A, \bar{B}	t_{WH}, t_{WL}	2	80	-	-	100	-	-	120	-	-	ns
		4.5	16	-	-	20	-	-	24	-	-	ns
		6	14	-	-	17	-	-	20	-	-	ns
\bar{R}	t_{WL}	2	80	-	-	100	-	-	120	-	-	ns
		4.5	16	-	-	20	-	-	24	-	-	ns
		6	14	-	-	17	-	-	20	-	-	ns
Reset Recovery Time	t_{REC}	2	5	-	-	5	-	-	5	-	-	ns
		4.5	5	-	-	5	-	-	5	-	-	ns
		6	5	-	-	5	-	-	5	-	-	ns
Retrigger Time (Figure 11)	t_{rT}	5	-	175	-	-	-	-	-	-	-	ns
HCT TYPES												
Input Pulse Widths A, \bar{B}	t_{WH}, t_{WL}	4.5	16	-	-	20	-	-	24	-	-	ns
		\bar{R}	t_{WL}	4.5	20	-	-	25	-	-	30	-
Reset Recovery Time	t_{REC}	4.5	5	-	-	5	-	-	5	-	-	ns
Retrigger Time (Figure 11)	t_{rT}	5	-	175	-	-	-	-	-	-	-	ns

CD54HC4538, CD74HC4538, CD54HCT4538, CD74HCT4538

Switching Specifications $C_L = 50\text{pF}$, Input $t_r, t_f = 6\text{ns}$, $R_X = 10\text{K}\Omega$, $C_X = 0$

PARAMETER	SYMBOL	TEST CONDITIONS	V_{CC} (V)	25°C			-40°C TO 85°C		-55°C TO 125°C		UNITS
				MIN	TYP	MAX	MIN	MAX	MIN	MAX	
HC TYPES											
Propagation Delay A, \bar{B} to Q	t_{PLH}	$C_L = 50\text{pF}$	2	-	-	250	-	315	-	375	ns
			4.5	-	-	50	-	63	-	75	ns
		$C_L = 15\text{pF}$	5	-	21	-	-	-	-	-	ns
		$C_L = 50\text{pF}$	6	-	-	43	-	54	-	64	ns
A, \bar{B} to \bar{Q}	t_{PHL}	$C_L = 50\text{pF}$	2	-	-	250	-	315	-	375	ns
			4.5	-	-	50	-	63	-	75	ns
		$C_L = 15\text{pF}$	5	-	21	-	-	-	-	-	ns
		$C_L = 50\text{pF}$	6	-	-	43	-	54	-	64	ns
\bar{R} to Q	t_{PHL}	$C_L = 50\text{pF}$	2	-	-	250	-	315	-	375	ns
			4.5	-	-	50	-	63	-	75	ns
		$C_L = 15\text{pF}$	5	-	21	-	-	-	-	-	ns
		$C_L = 50\text{pF}$	6	-	-	43	-	54	-	64	ns
\bar{R} to \bar{Q}	t_{PLH}	$C_L = 50\text{pF}$	2	-	-	250	-	315	-	375	ns
			4.5	-	-	50	-	63	-	75	ns
		$C_L = 15\text{pF}$	5	-	21	-	-	-	-	-	ns
		$C_L = 50\text{pF}$	6	-	-	43	-	54	-	64	ns
Output Transition Time	t_{TLH}, t_{THL}	$C_L = 50\text{pF}$	2	-	-	75	-	95	-	110	ns
			4.5	-	-	15	-	19	-	22	ns
			6	-	-	13	-	16	-	19	ns
Output Pulse Width $R_X = 10\text{k}$, $C_X = 0.1\mu\text{F}$	τ	$C_L = 50\text{pF}$	3	0.64	-	0.78	0.612	0.812	0.605	0.819	ms
			5	0.63	-	0.77	0.602	0.798	0.595	0.805	ms
Output Pulse Width Match, Same Package	-	-	-	-	± 1	-	-	-	-	%	
Power Dissipation Capacitance (Notes 8, 9)	C_{PD}	$C_L = 15\text{pF}$	5	-	136	-	-	-	-	-	pF
Input Capacitance	C_I	$C_L = 50\text{pF}$	-	10	-	10	-	10	-	10	pF
HCT TYPES											
Propagation Delay A, \bar{B} to Q	t_{PLH}	$C_L = 50\text{pF}$	4.5	-	-	55	-	69	-	83	ns
		$C_L = 15\text{pF}$	5	-	23	-	-	-	-	-	ns
A, \bar{B} to \bar{Q}	t_{PHL}	$C_L = 50\text{pF}$	4.5	-	-	55	-	69	-	83	ns
		$C_L = 15\text{pF}$	5	-	23	-	-	-	-	-	ns

CD54HC4538, CD74HC4538, CD54HCT4538, CD74HCT4538

Switching Specifications $C_L = 50\text{pF}$, Input $t_r, t_f = 6\text{ns}$, $R_X = 10\text{K}\Omega$, $C_X = 0$ (Continued)

PARAMETER	SYMBOL	TEST CONDITIONS	V_{CC} (V)	25°C			-40°C TO 85°C		-55°C TO 125°C		UNITS
				MIN	TYP	MAX	MIN	MAX	MIN	MAX	
\bar{R} to Q	t_{PHL}	$C_L = 50\text{pF}$	4.5	-	-	40	-	50	-	60	ns
		$C_L = 15\text{pF}$	5	-	17	-	-	-	-	-	ns
\bar{R} to \bar{Q}	t_{PLH}	$C_L = 50\text{pF}$	4.5	-	-	50	-	63	-	75	ns
		$C_L = 15\text{pF}$	5	-	21	-	-	-	-	-	ns
Output Transition Time	t_{TLH}, t_{THL}	$C_L = 50\text{pF}$	4.5	-	-	15	-	19	-	22	ns
Output Pulse Width $R_X = 10\text{k}$, $C_X = 0.1\mu\text{F}$	τ	$C_L = 50\text{pF}$	5	0.63	-	0.77	0.602	0.798	0.595	0.805	ms
Output Pulse Width Match, Same Package	-	-	-	-	± 1	-	-	-	-	-	%
Power Dissipation Capacitance (Notes 8, 9)	C_{PD}	$C_L = 15\text{pF}$	5	-	134	-	-	-	-	-	pF
Input Capacitance	C_i	$C_L = 50\text{pF}$	-	10	-	10	-	10	-	10	pF

NOTES:

8. C_{PD} is used to determine the dynamic power consumption, per one shot.
9. $P_D = (C_{PD} + C_X) V_{CC}^2 f_i \sum (C_L V_{CC}^2 f_O)$ where f_i = input frequency, f_O = output frequency, C_L = output load capacitance, C_X = external capacitance V_{CC} = supply voltage assuming $f_i \ll \frac{1}{\tau}$

Test Circuits and Waveforms

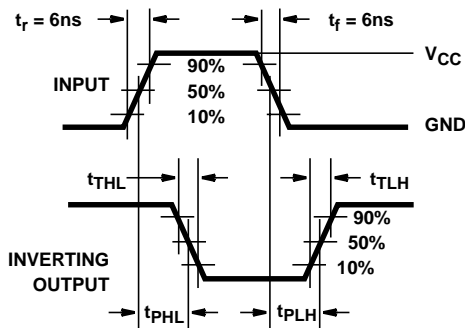

FIGURE 6. HC AND HCU TRANSITION TIMES AND PROPAGATION DELAY TIMES, COMBINATION LOGIC

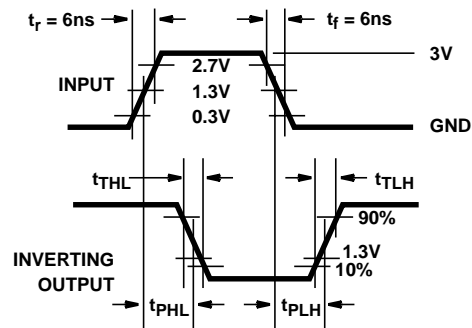

FIGURE 7. HCT TRANSITION TIMES AND PROPAGATION DELAY TIMES, COMBINATION LOGIC

Typical Performance Curves

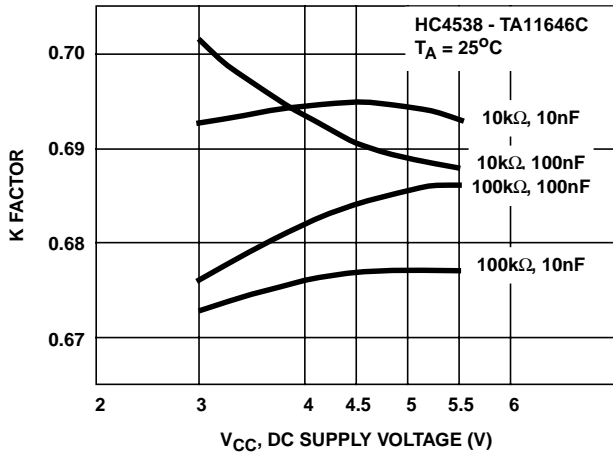

FIGURE 8. K FACTOR vs DC SUPPLY VOLTAGE (V_{CC}) - V

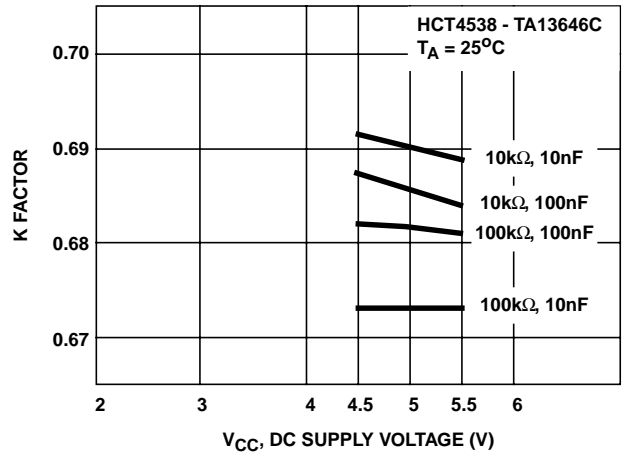

FIGURE 9. K FACTOR vs DC SUPPLY VOLTAGE (V_{CC}) - V

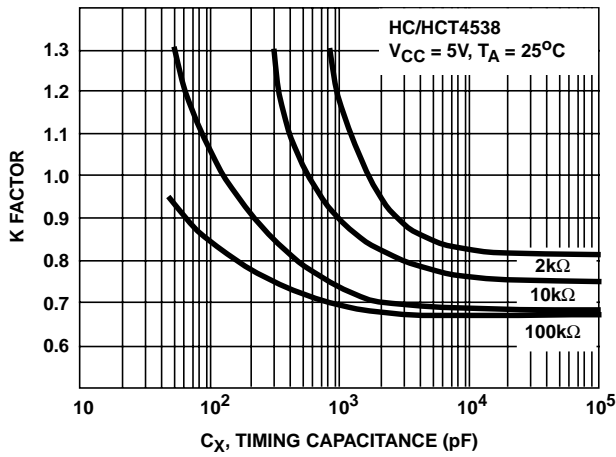

FIGURE 10. K FACTOR vs C_X

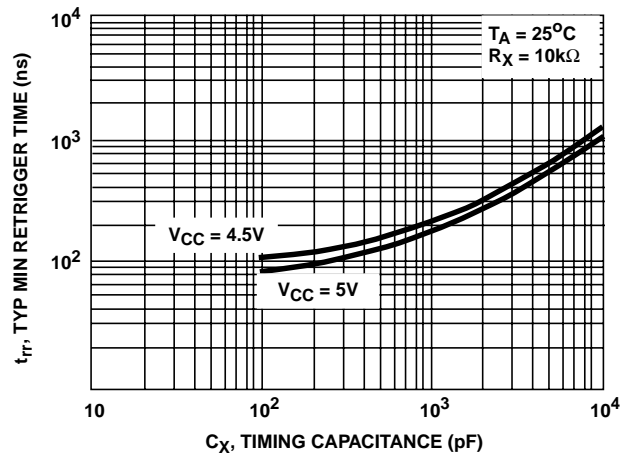

FIGURE 11. MINIMUM RETRIGGER TIME vs TIMING CAPACITANCE

Power-Down Mode

During a rapid power-down condition, as would occur with a power-supply short circuit with a poorly filtered power supply, the energy stored in C_X could discharge into Pin 2 or 14. To avoid possible device damage in this mode, when C_X is $\geq 0.5\mu\text{F}$, a protection diode with a 1 ampere or higher rating (1N5395 or equivalent) and a separate ground return for C_X should be provided as shown in Figure 12.

An alternate protection method is shown in Figure 13, where a 51Ω current-limiting resistor is inserted in series with C_X . Note that a small pulse width decrease will occur however, and R_X must be appropriately increased to obtain the originally desired pulse width.

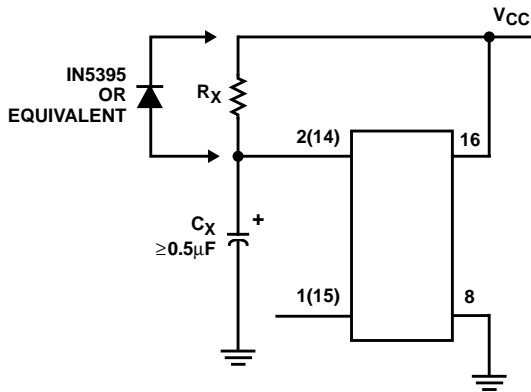

FIGURE 12. RAPID POWER-DOWN PROTECTION CIRCUIT

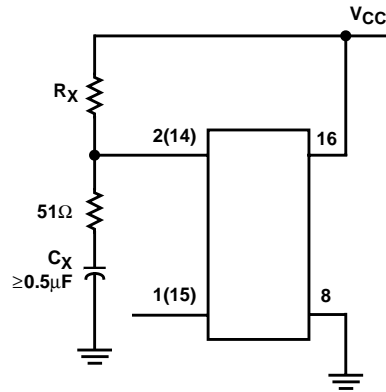

FIGURE 13. ALTERNATE RAPID POWER-DOWN PROTECTION CIRCUIT

PACKAGING INFORMATION

Orderable Device	Status ⁽¹⁾	Package Type	Package Drawing	Pins	Package Qty	Eco Plan ⁽²⁾	Lead/Ball Finish	MSL Peak Temp ⁽³⁾
5962-8688601EA	ACTIVE	CDIP	J	16	1	TBD	A42	N / A for Pkg Type
CD54HC4538F	ACTIVE	CDIP	J	16	1	TBD	A42	N / A for Pkg Type
CD54HC4538F3A	ACTIVE	CDIP	J	16	1	TBD	A42	N / A for Pkg Type
CD54HCT4538F3A	ACTIVE	CDIP	J	16	1	TBD	A42	N / A for Pkg Type
CD74HC4538E	ACTIVE	PDIP	N	16	25	Pb-Free (RoHS)	CU NIPDAU	N / A for Pkg Type
CD74HC4538EE4	ACTIVE	PDIP	N	16	25	Pb-Free (RoHS)	CU NIPDAU	N / A for Pkg Type
CD74HC4538M	ACTIVE	SOIC	D	16	40	Green (RoHS & no Sb/Br)	CU NIPDAU	Level-1-260C-UNLIM
CD74HC4538M96	ACTIVE	SOIC	D	16	2500	Green (RoHS & no Sb/Br)	CU NIPDAU	Level-1-260C-UNLIM
CD74HC4538M96E4	ACTIVE	SOIC	D	16	2500	Green (RoHS & no Sb/Br)	CU NIPDAU	Level-1-260C-UNLIM
CD74HC4538M96G4	ACTIVE	SOIC	D	16	2500	Green (RoHS & no Sb/Br)	CU NIPDAU	Level-1-260C-UNLIM
CD74HC4538ME4	ACTIVE	SOIC	D	16	40	Green (RoHS & no Sb/Br)	CU NIPDAU	Level-1-260C-UNLIM
CD74HC4538MG4	ACTIVE	SOIC	D	16	40	Green (RoHS & no Sb/Br)	CU NIPDAU	Level-1-260C-UNLIM
CD74HC4538MT	ACTIVE	SOIC	D	16	250	Green (RoHS & no Sb/Br)	CU NIPDAU	Level-1-260C-UNLIM
CD74HC4538MTE4	ACTIVE	SOIC	D	16	250	Green (RoHS & no Sb/Br)	CU NIPDAU	Level-1-260C-UNLIM
CD74HC4538MTG4	ACTIVE	SOIC	D	16	250	Green (RoHS & no Sb/Br)	CU NIPDAU	Level-1-260C-UNLIM
CD74HC4538NSR	ACTIVE	SO	NS	16	2000	Green (RoHS & no Sb/Br)	CU NIPDAU	Level-1-260C-UNLIM
CD74HC4538NSRE4	ACTIVE	SO	NS	16	2000	Green (RoHS & no Sb/Br)	CU NIPDAU	Level-1-260C-UNLIM
CD74HC4538NSRG4	ACTIVE	SO	NS	16	2000	Green (RoHS & no Sb/Br)	CU NIPDAU	Level-1-260C-UNLIM
CD74HC4538PW	ACTIVE	TSSOP	PW	16	90	Green (RoHS & no Sb/Br)	CU NIPDAU	Level-1-260C-UNLIM
CD74HC4538PWE4	ACTIVE	TSSOP	PW	16	90	Green (RoHS & no Sb/Br)	CU NIPDAU	Level-1-260C-UNLIM
CD74HC4538PWG4	ACTIVE	TSSOP	PW	16	90	Green (RoHS & no Sb/Br)	CU NIPDAU	Level-1-260C-UNLIM
CD74HC4538PWR	ACTIVE	TSSOP	PW	16	2000	Green (RoHS & no Sb/Br)	CU NIPDAU	Level-1-260C-UNLIM
CD74HC4538PWRE4	ACTIVE	TSSOP	PW	16	2000	Green (RoHS & no Sb/Br)	CU NIPDAU	Level-1-260C-UNLIM
CD74HC4538PWRG4	ACTIVE	TSSOP	PW	16	2000	Green (RoHS & no Sb/Br)	CU NIPDAU	Level-1-260C-UNLIM
CD74HC4538PWT	ACTIVE	TSSOP	PW	16	250	Green (RoHS & no Sb/Br)	CU NIPDAU	Level-1-260C-UNLIM
CD74HC4538PWTE4	ACTIVE	TSSOP	PW	16	250	Green (RoHS & no Sb/Br)	CU NIPDAU	Level-1-260C-UNLIM
CD74HC4538PWTG4	ACTIVE	TSSOP	PW	16	250	Green (RoHS & no Sb/Br)	CU NIPDAU	Level-1-260C-UNLIM

Orderable Device	Status ⁽¹⁾	Package Type	Package Drawing	Pins	Package Qty	Eco Plan ⁽²⁾	Lead/Ball Finish	MSL Peak Temp ⁽³⁾
						no Sb/Br)		
CD74HCT4538E	ACTIVE	PDIP	N	16	25	Pb-Free (RoHS)	CU NIPDAU	N / A for Pkg Type
CD74HCT4538EE4	ACTIVE	PDIP	N	16	25	Pb-Free (RoHS)	CU NIPDAU	N / A for Pkg Type
CD74HCT4538M	ACTIVE	SOIC	D	16	40	Green (RoHS & no Sb/Br)	CU NIPDAU	Level-1-260C-UNLIM
CD74HCT4538M96	ACTIVE	SOIC	D	16	2500	Green (RoHS & no Sb/Br)	CU NIPDAU	Level-1-260C-UNLIM
CD74HCT4538M96E4	ACTIVE	SOIC	D	16	2500	Green (RoHS & no Sb/Br)	CU NIPDAU	Level-1-260C-UNLIM
CD74HCT4538M96G4	ACTIVE	SOIC	D	16	2500	Green (RoHS & no Sb/Br)	CU NIPDAU	Level-1-260C-UNLIM
CD74HCT4538ME4	ACTIVE	SOIC	D	16	40	Green (RoHS & no Sb/Br)	CU NIPDAU	Level-1-260C-UNLIM
CD74HCT4538MG4	ACTIVE	SOIC	D	16	40	Green (RoHS & no Sb/Br)	CU NIPDAU	Level-1-260C-UNLIM
CD74HCT4538MT	ACTIVE	SOIC	D	16	250	Green (RoHS & no Sb/Br)	CU NIPDAU	Level-1-260C-UNLIM
CD74HCT4538MTE4	ACTIVE	SOIC	D	16	250	Green (RoHS & no Sb/Br)	CU NIPDAU	Level-1-260C-UNLIM
CD74HCT4538MTG4	ACTIVE	SOIC	D	16	250	Green (RoHS & no Sb/Br)	CU NIPDAU	Level-1-260C-UNLIM

⁽¹⁾ The marketing status values are defined as follows:

ACTIVE: Product device recommended for new designs.

LIFEBUY: TI has announced that the device will be discontinued, and a lifetime-buy period is in effect.

NRND: Not recommended for new designs. Device is in production to support existing customers, but TI does not recommend using this part in a new design.

PREVIEW: Device has been announced but is not in production. Samples may or may not be available.

OBSOLETE: TI has discontinued the production of the device.

⁽²⁾ Eco Plan - The planned eco-friendly classification: Pb-Free (RoHS), Pb-Free (RoHS Exempt), or Green (RoHS & no Sb/Br) - please check <http://www.ti.com/productcontent> for the latest availability information and additional product content details.

TBD: The Pb-Free/Green conversion plan has not been defined.

Pb-Free (RoHS): TI's terms "Lead-Free" or "Pb-Free" mean semiconductor products that are compatible with the current RoHS requirements for all 6 substances, including the requirement that lead not exceed 0.1% by weight in homogeneous materials. Where designed to be soldered at high temperatures, TI Pb-Free products are suitable for use in specified lead-free processes.

Pb-Free (RoHS Exempt): This component has a RoHS exemption for either 1) lead-based flip-chip solder bumps used between the die and package, or 2) lead-based die adhesive used between the die and leadframe. The component is otherwise considered Pb-Free (RoHS compatible) as defined above.

Green (RoHS & no Sb/Br): TI defines "Green" to mean Pb-Free (RoHS compatible), and free of Bromine (Br) and Antimony (Sb) based flame retardants (Br or Sb do not exceed 0.1% by weight in homogeneous material)

⁽³⁾ MSL, Peak Temp. -- The Moisture Sensitivity Level rating according to the JEDEC industry standard classifications, and peak solder temperature.

Important Information and Disclaimer:The information provided on this page represents TI's knowledge and belief as of the date that it is provided. TI bases its knowledge and belief on information provided by third parties, and makes no representation or warranty as to the accuracy of such information. Efforts are underway to better integrate information from third parties. TI has taken and continues to take reasonable steps to provide representative and accurate information but may not have conducted destructive testing or chemical analysis on incoming materials and chemicals. TI and TI suppliers consider certain information to be proprietary, and thus CAS numbers and other limited information may not be available for release.

In no event shall TI's liability arising out of such information exceed the total purchase price of the TI part(s) at issue in this document sold by TI to Customer on an annual basis.

OTHER QUALIFIED VERSIONS OF CD54HC4538, CD54HCT4538, CD74HC4538, CD74HCT4538 :

- Automotive: [CD74HC4538-Q1](#)

NOTE: Qualified Version Definitions:

- Automotive - Q100 devices qualified for high-reliability automotive applications targeting zero defects

TAPE AND REEL INFORMATION

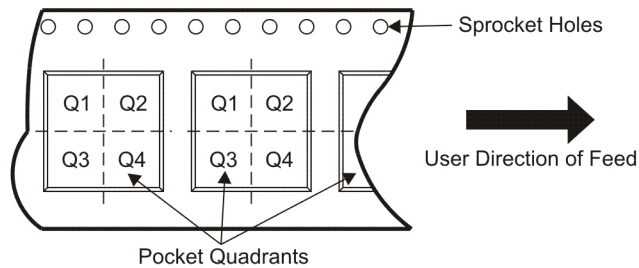
QUADRANT ASSIGNMENTS FOR PIN 1 ORIENTATION IN TAPE

*All dimensions are nominal

Device	Package Type	Package Drawing	Pins	SPQ	Reel Diameter (mm)	Reel Width W1 (mm)	A0 (mm)	B0 (mm)	K0 (mm)	P1 (mm)	W (mm)	Pin1 Quadrant
CD74HC4538M96	SOIC	D	16	2500	330.0	16.4	6.5	10.3	2.1	8.0	16.0	Q1
CD74HC4538NSR	SO	NS	16	2000	330.0	16.4	8.2	10.5	2.5	12.0	16.0	Q1
CD74HC4538PWR	TSSOP	PW	16	2000	330.0	12.4	6.9	5.6	1.6	8.0	12.0	Q1
CD74HC4538PWT	TSSOP	PW	16	250	330.0	12.4	6.9	5.6	1.6	8.0	12.0	Q1
CD74HCT4538M96	SOIC	D	16	2500	330.0	16.4	6.5	10.3	2.1	8.0	16.0	Q1

TAPE AND REEL BOX DIMENSIONS

*All dimensions are nominal

Device	Package Type	Package Drawing	Pins	SPQ	Length (mm)	Width (mm)	Height (mm)
CD74HC4538M96	SOIC	D	16	2500	333.2	345.9	28.6
CD74HC4538NSR	SO	NS	16	2000	346.0	346.0	33.0
CD74HC4538PWR	TSSOP	PW	16	2000	346.0	346.0	29.0
CD74HC4538PWT	TSSOP	PW	16	250	346.0	346.0	29.0
CD74HCT4538M96	SOIC	D	16	2500	333.2	345.9	28.6

J (R-GDIP-T**)

14 LEADS SHOWN

CERAMIC DUAL IN-LINE PACKAGE



DIM \ PINS **	14	16	18	20
A	0.300 (7,62) BSC	0.300 (7,62) BSC	0.300 (7,62) BSC	0.300 (7,62) BSC
B MAX	0.785 (19,94)	.840 (21,34)	0.960 (24,38)	1.060 (26,92)
B MIN	—	—	—	—
C MAX	0.300 (7,62)	0.300 (7,62)	0.310 (7,87)	0.300 (7,62)
C MIN	0.245 (6,22)	0.245 (6,22)	0.220 (5,59)	0.245 (6,22)



4040083/F 03/03

- NOTES:
- All linear dimensions are in inches (millimeters).
 - This drawing is subject to change without notice.
 - This package is hermetically sealed with a ceramic lid using glass frit.
 - Index point is provided on cap for terminal identification only on press ceramic glass frit seal only.
 - Falls within MIL STD 1835 GDIP1-T14, GDIP1-T16, GDIP1-T18 and GDIP1-T20.

N (R-PDIP-T**)

PLASTIC DUAL-IN-LINE PACKAGE

16 PINS SHOWN



- NOTES:
- A. All linear dimensions are in inches (millimeters).
 - B. This drawing is subject to change without notice.
 - Falls within JEDEC MS-001, except 18 and 20 pin minimum body length (Dim A).
 - The 20 pin end lead shoulder width is a vendor option, either half or full width.

D (R-PDSO-G16)

PLASTIC SMALL-OUTLINE PACKAGE

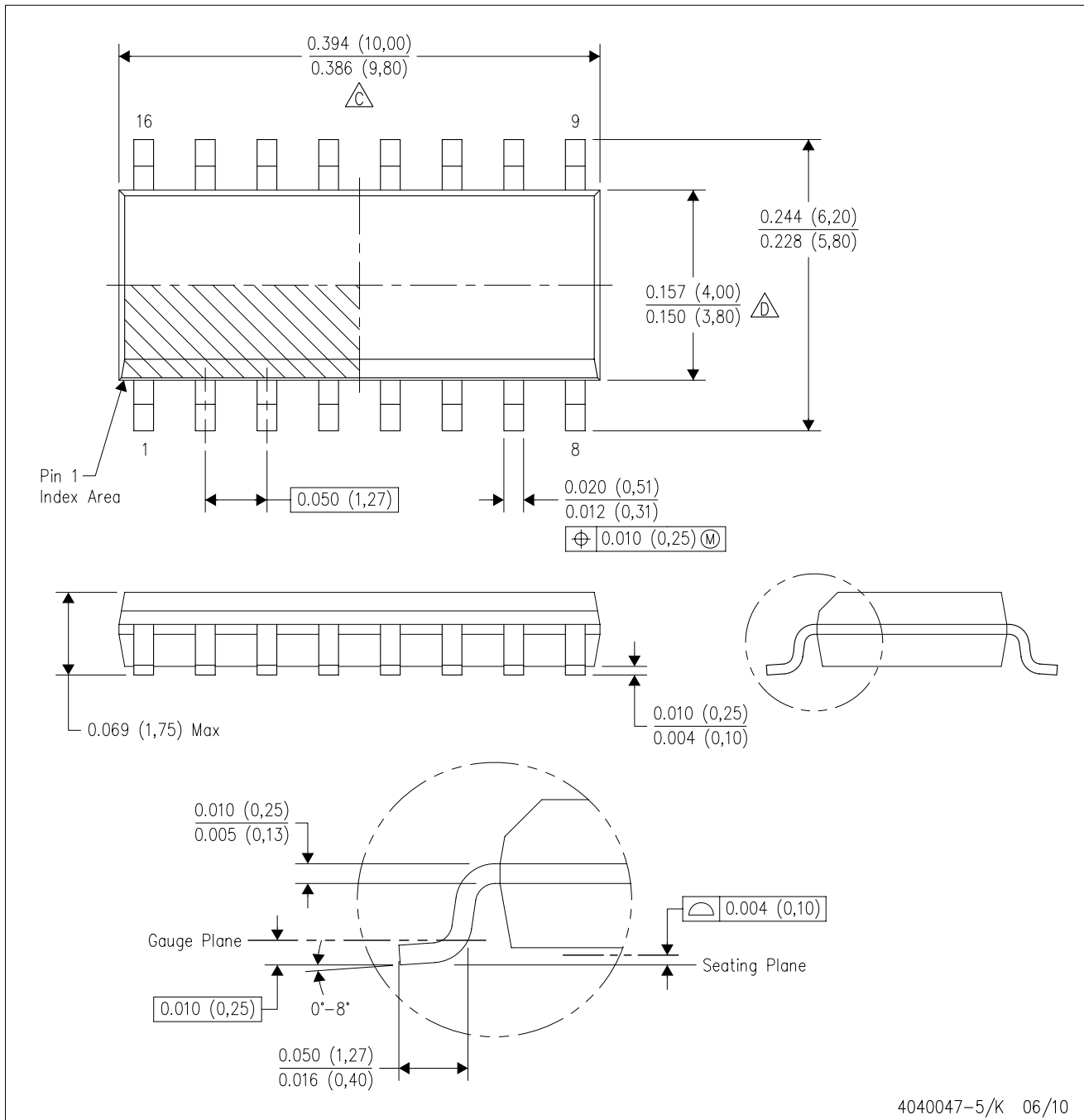

- NOTES:
- A. All linear dimensions are in inches (millimeters).
 - B. This drawing is subject to change without notice.
 - C. Body length does not include mold flash, protrusions, or gate burrs. Mold flash, protrusions, or gate burrs shall not exceed .006 (0,15) per end.
 - D. Body width does not include interlead flash. Interlead flash shall not exceed .017 (0,43) per side.
 - E. Reference JEDEC MS-012 variation AC.

D (R-PDSO-G16)

PLASTIC SMALL OUTLINE

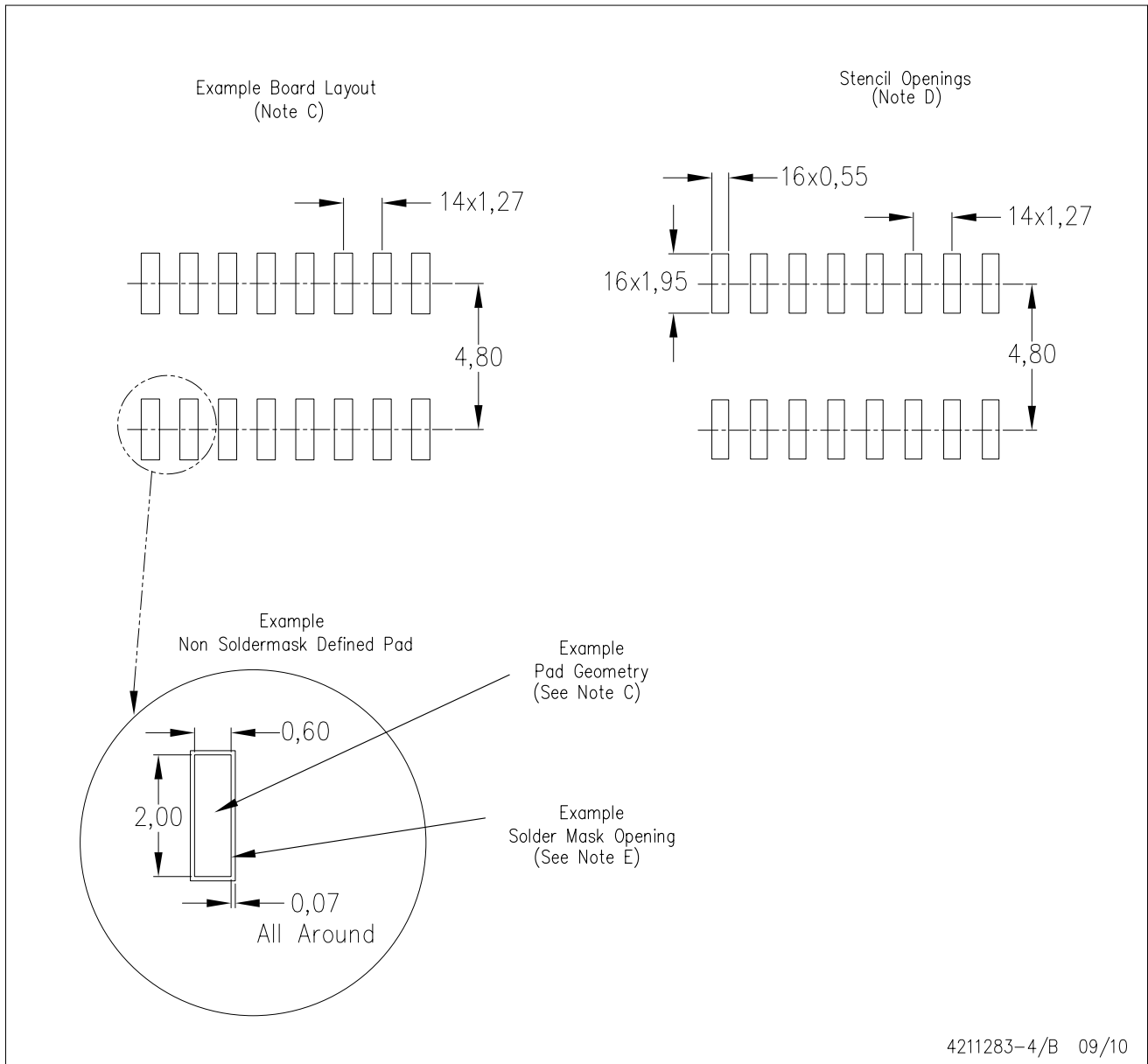

- NOTES:
- All linear dimensions are in millimeters.
 - This drawing is subject to change without notice.
 - Publication IPC-7351 is recommended for alternate designs.
 - Laser cutting apertures with trapezoidal walls and also rounding corners will offer better paste release. Customers should contact their board assembly site for stencil design recommendations. Refer to IPC-7525 for other stencil recommendations.
 - Customers should contact their board fabrication site for solder mask tolerances between and around signal pads.

MECHANICAL DATA

NS (R-PDSO-G**)

PLASTIC SMALL-OUTLINE PACKAGE

14-PINS SHOWN



- NOTES:
- A. All linear dimensions are in millimeters.
 - B. This drawing is subject to change without notice.
 - C. Body dimensions do not include mold flash or protrusion, not to exceed 0,15.

PW (R-PDSO-G**)

PLASTIC SMALL-OUTLINE PACKAGE

14 PINS SHOWN



4040064/F 01/97

- NOTES: A. All linear dimensions are in millimeters.
 B. This drawing is subject to change without notice.
 C. Body dimensions do not include mold flash or protrusion not to exceed 0,15.
 D. Falls within JEDEC MO-153

PW (R-PDSO-G16)

PLASTIC SMALL OUTLINE

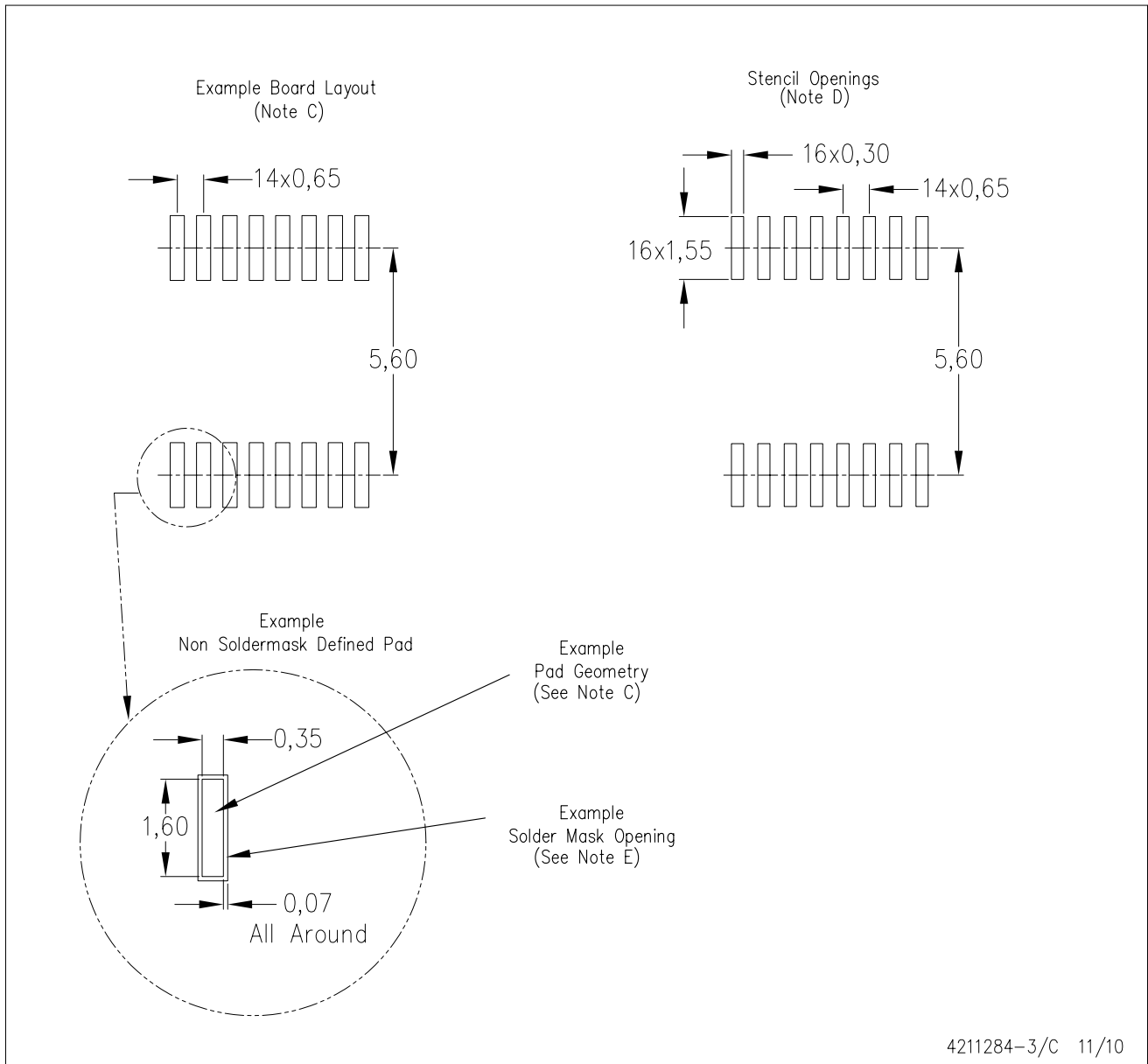

- NOTES:
- All linear dimensions are in millimeters.
 - This drawing is subject to change without notice.
 - Publication IPC-7351 is recommended for alternate designs.
 - Laser cutting apertures with trapezoidal walls and also rounding corners will offer better paste release. Customers should contact their board assembly site for stencil design recommendations. Refer to IPC-7525 for other stencil recommendations.
 - Customers should contact their board fabrication site for solder mask tolerances between and around signal pads.

IMPORTANT NOTICE

Texas Instruments Incorporated and its subsidiaries (TI) reserve the right to make corrections, modifications, enhancements, improvements, and other changes to its products and services at any time and to discontinue any product or service without notice. Customers should obtain the latest relevant information before placing orders and should verify that such information is current and complete. All products are sold subject to TI's terms and conditions of sale supplied at the time of order acknowledgment.

TI warrants performance of its hardware products to the specifications applicable at the time of sale in accordance with TI's standard warranty. Testing and other quality control techniques are used to the extent TI deems necessary to support this warranty. Except where mandated by government requirements, testing of all parameters of each product is not necessarily performed.

TI assumes no liability for applications assistance or customer product design. Customers are responsible for their products and applications using TI components. To minimize the risks associated with customer products and applications, customers should provide adequate design and operating safeguards.

TI does not warrant or represent that any license, either express or implied, is granted under any TI patent right, copyright, mask work right, or other TI intellectual property right relating to any combination, machine, or process in which TI products or services are used. Information published by TI regarding third-party products or services does not constitute a license from TI to use such products or services or a warranty or endorsement thereof. Use of such information may require a license from a third party under the patents or other intellectual property of the third party, or a license from TI under the patents or other intellectual property of TI.

Reproduction of TI information in TI data books or data sheets is permissible only if reproduction is without alteration and is accompanied by all associated warranties, conditions, limitations, and notices. Reproduction of this information with alteration is an unfair and deceptive business practice. TI is not responsible or liable for such altered documentation. Information of third parties may be subject to additional restrictions.

Resale of TI products or services with statements different from or beyond the parameters stated by TI for that product or service voids all express and any implied warranties for the associated TI product or service and is an unfair and deceptive business practice. TI is not responsible or liable for any such statements.

TI products are not authorized for use in safety-critical applications (such as life support) where a failure of the TI product would reasonably be expected to cause severe personal injury or death, unless officers of the parties have executed an agreement specifically governing such use. Buyers represent that they have all necessary expertise in the safety and regulatory ramifications of their applications, and acknowledge and agree that they are solely responsible for all legal, regulatory and safety-related requirements concerning their products and any use of TI products in such safety-critical applications, notwithstanding any applications-related information or support that may be provided by TI. Further, Buyers must fully indemnify TI and its representatives against any damages arising out of the use of TI products in such safety-critical applications.

TI products are neither designed nor intended for use in military/aerospace applications or environments unless the TI products are specifically designated by TI as military-grade or "enhanced plastic." Only products designated by TI as military-grade meet military specifications. Buyers acknowledge and agree that any such use of TI products which TI has not designated as military-grade is solely at the Buyer's risk, and that they are solely responsible for compliance with all legal and regulatory requirements in connection with such use.

TI products are neither designed nor intended for use in automotive applications or environments unless the specific TI products are designated by TI as compliant with ISO/TS 16949 requirements. Buyers acknowledge and agree that, if they use any non-designated products in automotive applications, TI will not be responsible for any failure to meet such requirements.

Following are URLs where you can obtain information on other Texas Instruments products and application solutions:

Products		Applications	
Amplifiers	amplifier.ti.com	Audio	www.ti.com/audio
Data Converters	dataconverter.ti.com	Automotive	www.ti.com/automotive
DLP® Products	www.dlp.com	Communications and Telecom	www.ti.com/communications
DSP	dsp.ti.com	Computers and Peripherals	www.ti.com/computers
Clocks and Timers	www.ti.com/clocks	Consumer Electronics	www.ti.com/consumer-apps
Interface	interface.ti.com	Energy	www.ti.com/energy
Logic	logic.ti.com	Industrial	www.ti.com/industrial
Power Mgmt	power.ti.com	Medical	www.ti.com/medical
Microcontrollers	microcontroller.ti.com	Security	www.ti.com/security
RFID	www.ti-rfid.com	Space, Avionics & Defense	www.ti.com/space-avionics-defense
RF/IF and ZigBee® Solutions	www.ti.com/lprf	Video and Imaging	www.ti.com/video
		Wireless	www.ti.com/wireless-apps

Mailing Address: Texas Instruments, Post Office Box 655303, Dallas, Texas 75265
Copyright © 2010, Texas Instruments Incorporated