

## High-Speed CMOS Logic Analog Multiplexers/Demultiplexers with Latch

### Features

- Wide Analog Input Voltage Range . . . . .  $\pm 5V$  (Max)
- Low "On" Resistance
  - $V_{CC} - V_{EE} = 4.5V$  . . . . .  $70\Omega$  (Typ)
  - $V_{CC} - V_{EE} = 9V$  . . . . .  $40\Omega$  (Typ)
- Low Crosstalk Between Switches
- Fast Switching and Propagation Speeds
- "Break-Before-Make" Switching
- Wide Operating Temperature Range . . .  $-55^{\circ}C$  to  $125^{\circ}C$
- HC Types
  - 2V to 6V Operation, Control; 0V to 10V Switch
  - High Noise Immunity:  $N_{IL} = 30\%$ ,  $N_{IH} = 30\%$  of  $V_{CC}$  at  $V_{CC} = 5V$
- HCT Types
  - 4.5V to 5.5V Operation, Control; 0V to 10V Switch
  - Direct LSTTL Input Logic Compatibility,  $V_{IL} = 0.8V$  (Max),  $V_{IH} = 2V$  (Min)
  - CMOS Input Compatibility,  $I_I \leq 1\mu A$  at  $V_{OL}$ ,  $V_{OH}$

### Description

The 'HC4351, CD74HCT4351, and CD74HC4352 are digitally controlled analog switches which utilize silicon-gate

CMOS technology to achieve operating speeds similar to LSTTL with the low power consumption of standard CMOS integrated circuits.

These analog multiplexers/demultiplexers are, in essence, the HC/HCT4015 and HC4052 preceded by address latches that are controlled by an active low Latch Enable input ( $\overline{LE}$ ). Two Enable inputs, one active low ( $\overline{E1}$ ), and the other active high (E2) are provided allowing enabling with either input voltage level.

### Ordering Information

PART NUMBER	TEMP. RANGE (°C)	PACKAGE
CD54HC4351F3A	-55 to 125	20 Ld CERDIP
CD74HC4351E	-55 to 125	20 Ld PDIP
CD74HC4351M	-55 to 125	20 Ld SOIC
CD74HC4351M96	-55 to 125	20 Ld SOIC
CD74HCT4351E	-55 to 125	20 Ld PDIP
CD74HC4352E	-55 to 125	20 Ld PDIP

NOTE: When ordering, use the entire part number. The suffix 96 denotes tape and reel.

### Pinouts

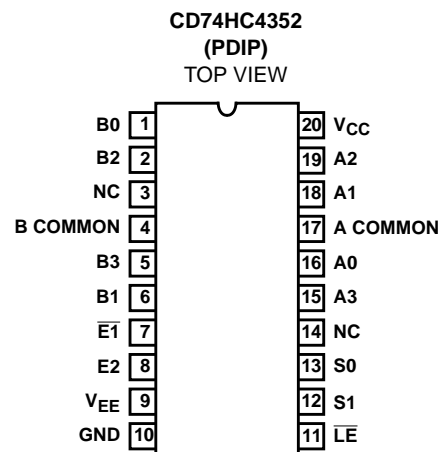
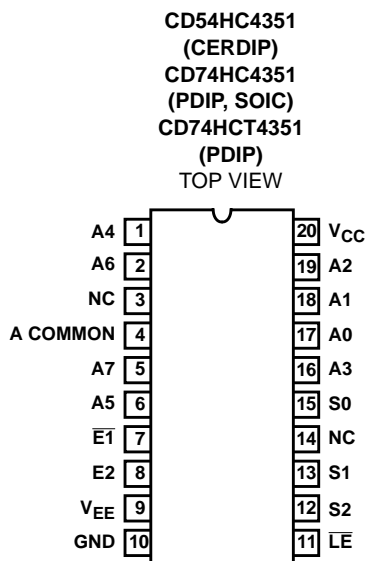

Functional Diagram

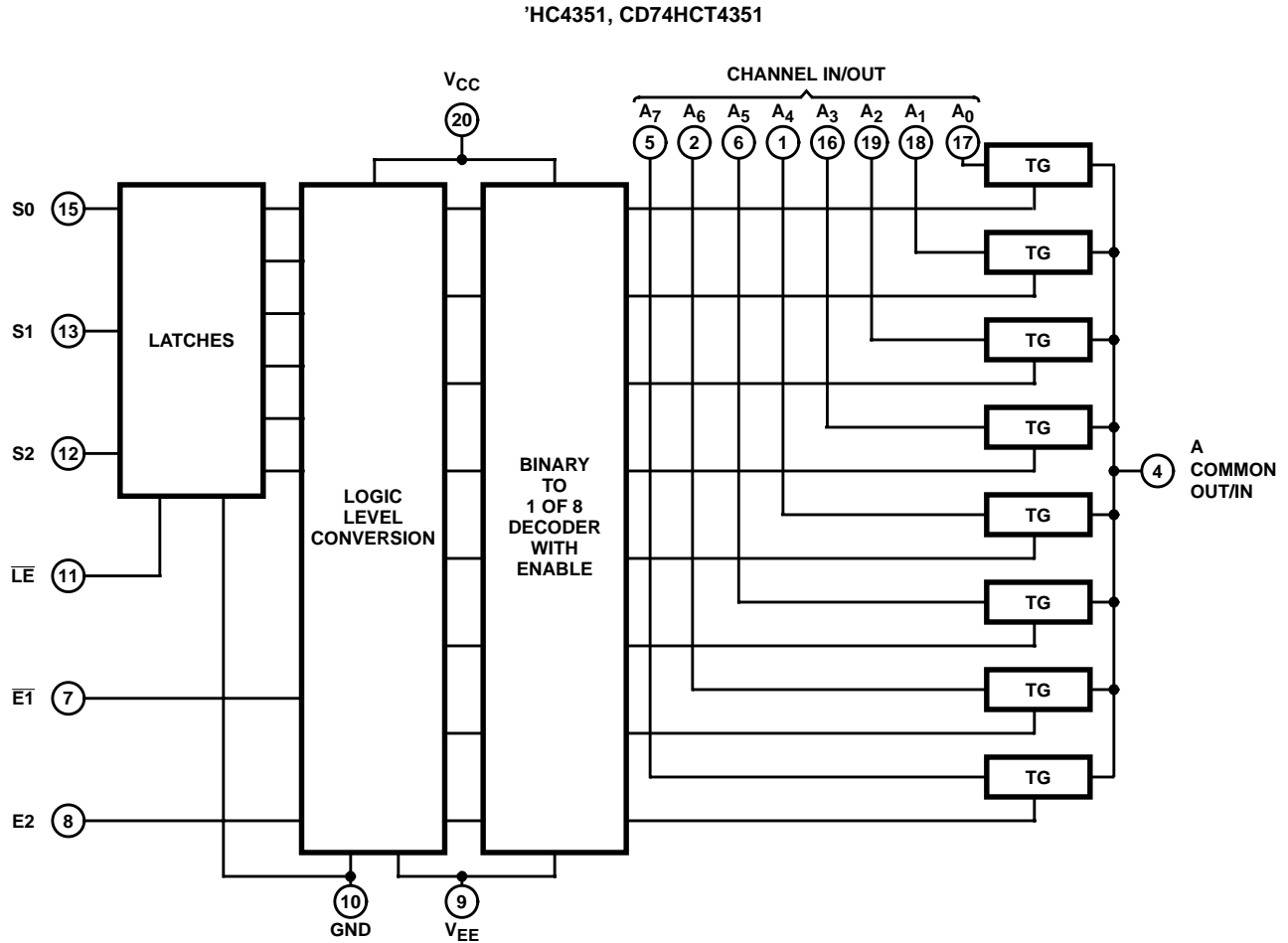

TRUTH TABLE  
'HC4351, CD74HCT4351

INPUT STATES					(NOTE 1) "ON" SWITCHES $\overline{LE} = H$
$\overline{E1}$	E2	S2	S1	S0	
L	H	L	L	L	A <sub>0</sub>
L	H	L	L	H	A <sub>1</sub>
L	H	L	H	L	A <sub>2</sub>
L	H	L	H	H	A <sub>3</sub>
L	H	H	L	L	A <sub>4</sub>
L	H	H	L	H	A <sub>5</sub>
L	H	H	H	L	A <sub>6</sub>
L	H	H	H	H	A <sub>7</sub>
H	L	X	X	X	None

H = High Voltage Level, L = Low Voltage Level, X = Don't Care

NOTE:

1. When  $\overline{LE}$  is low S0-S2 data are latched and switches cannot change state.

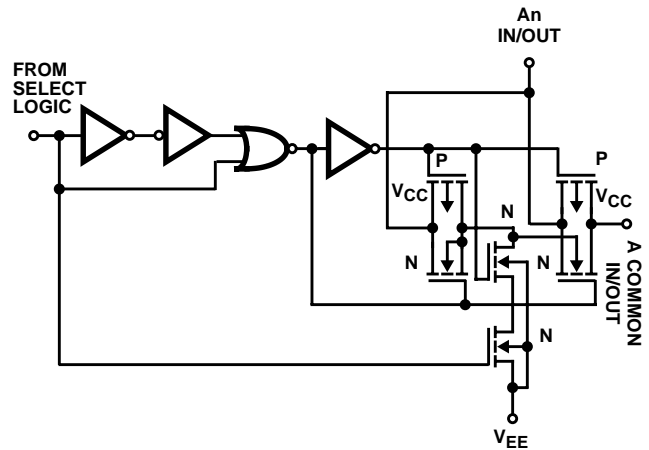
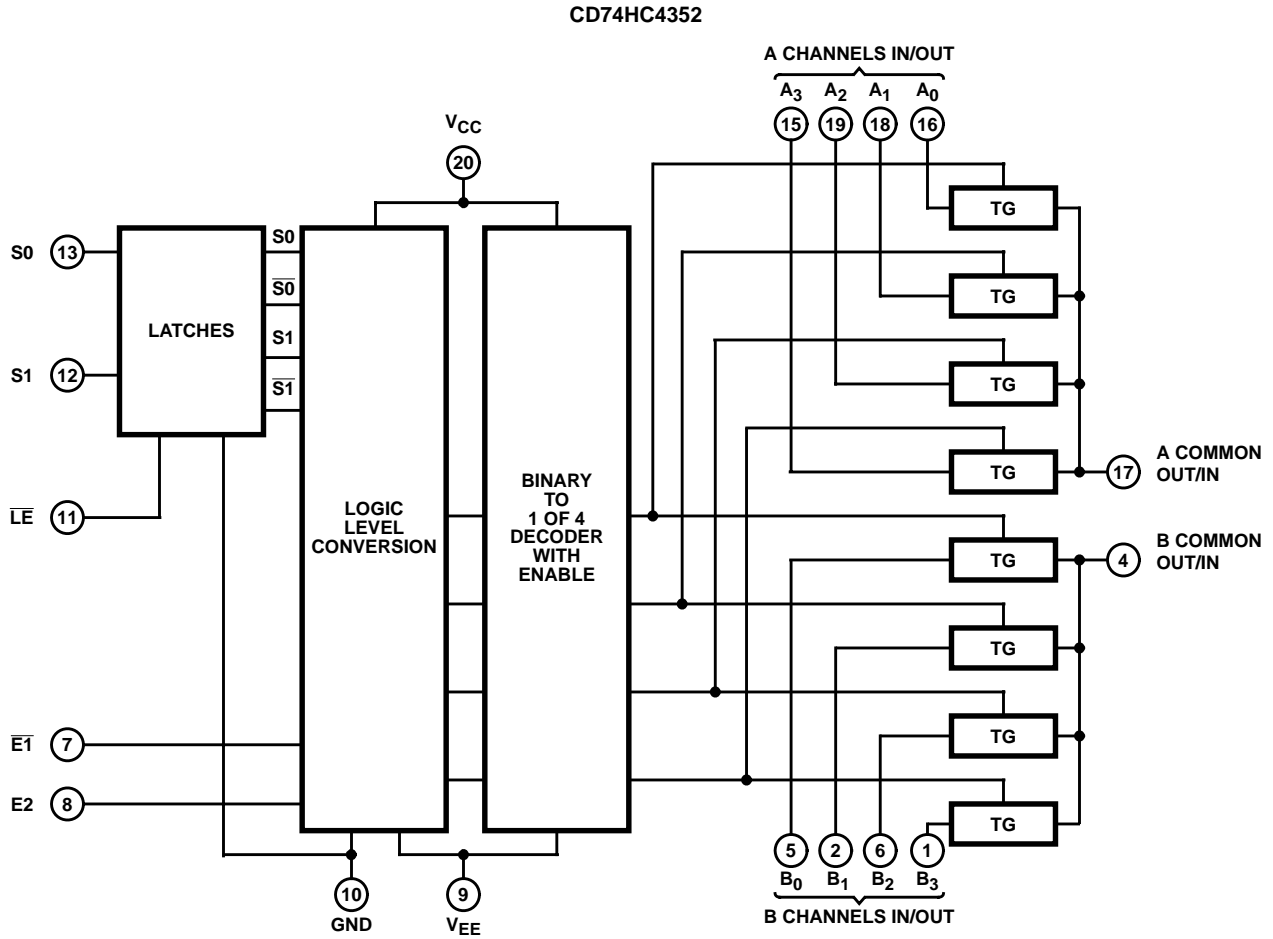

FIGURE 1. DETAIL OF ONE HC/HCT4351 SWITCH

Functional Diagram



TRUTH TABLE  
CD74HC4352

INPUT STATES				(NOTE 2) "ON" SWITCHES $\overline{LE} = H$
$\overline{E1}$	E2	S1	S0	
L	H	L	L	A <sub>0</sub> , B <sub>0</sub>
L	H	L	H	A <sub>1</sub> , B <sub>1</sub>
L	H	H	L	A <sub>2</sub> , B <sub>2</sub>
L	H	H	H	A <sub>3</sub> , B <sub>3</sub>
H	L	X	X	None

H = High Voltage Level, L = Low Voltage Level, X = Don't Care  
NOTE:

- When Latch Enable is "Low" channel-select data is latched and switches cannot change state.

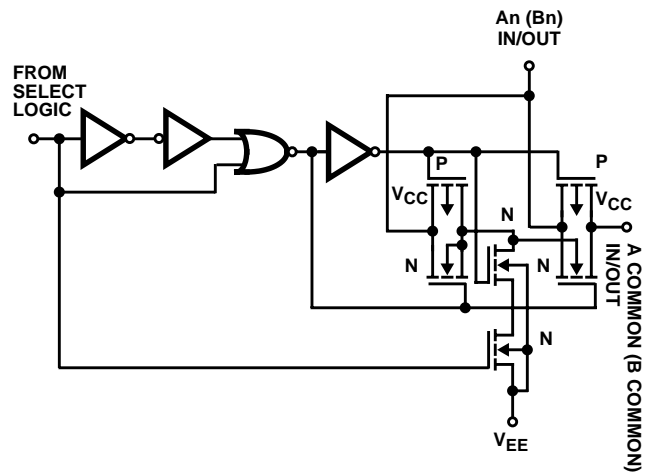

FIGURE 2. DETAIL OF ONE CD74HC4352 SWITCH

**Absolute Maximum Ratings**

DC Supply Voltage, $V_{CC}$ .....	-0.5V to 7V
DC Supply Voltage, $V_{CC} - V_{EE}$ .....	-0.5V to 10.5V
DC Supply Voltage, $V_{EE}$ .....	0.5V to -7V
DC Input Diode Current, $I_{IK}$ For $V_I < -0.5V$ or $V_I > V_{CC} + 0.5V$ .....	$\pm 20mA$
DC Switch Diode Current, $I_{OK}$ For $V_I < V_{EE} - 0.5V$ or $V_I < V_{CC} + 0.5V$ .....	$\pm 25mA$
DC Switch Current, $I_{OK}$ (Note 3) For $V_I > V_{EE} - 0.5V$ or $V_I < V_{CC} + 0.5V$ .....	$\pm 20mA$
DC Output Diode Current, $I_{OK}$ For $V_O < -0.5V$ or $V_O > V_{CC} + 0.5V$ .....	$\pm 20mA$
DC Output Source or Sink Current per Output Pin, $I_O$ For $V_O > -0.5V$ or $V_O < V_{CC} + 0.5V$ .....	$\pm 25mA$
DC $V_{CC}$ or Ground Current, $I_{CC}$ .....	$\pm 50mA$

**Operating Conditions**

Temperature Range, $T_A$ .....	-55°C to 125°C
Supply Voltage Range, $V_{CC}$ HC Types .....	.2V to 6V
HCT Types .....	4.5V to 5.5V
Supply Voltage Range, $V_{CC} - V_{EE}$ HC, HCT Types (Figure 3) .....	.2V to 10V
Supply Voltage Range, $V_{EE}$ HC, HCT Types (Figure 4) .....	0V to -6V
DC Input or Output Voltage, $V_I$ .....	GND to $V_{CC}$
Analog Switch I/O Voltage, $V_{IS}$ .....	$V_{EE}$ (Min) ..... $V_{CC}$ (Max)
Input Rise and Fall Time, $t_r, t_f$ 2V .....	1000ns (Max)
4.5V .....	500ns (Max)
6V .....	400ns (Max)

CAUTION: Stresses above those listed in "Absolute Maximum Ratings" may cause permanent damage to the device. This is a stress only rating and operation of the device at these or any other conditions above those indicated in the operational sections of this specification is not implied.

NOTES:

- In certain applications, the external load-resistor current may include both  $V_{CC}$  and signal-line components. To avoid drawing  $V_{CC}$  current when switch current flows into the transmission gate inputs, the voltage drop across the bidirectional switch must not exceed 0.6V (calculated from  $R_{ON}$  values shown in the DC Electrical Specifications table). No  $V_{CC}$  current will flow through  $R_L$  if the switch current flows into terminal 3 on the 'HC4351 and CD74HCT4351; terminals 3 and 13 on the CD74HC4352.
- The package thermal impedance is calculated in accordance with JESD 51-7.

**Thermal Information**

Thermal Resistance (Typical, Note 4)	$\theta_{JA}$ (°C/W)
E (PDIP) Package .....	69
M (SOIC) Package .....	58
Maximum Junction Temperature .....	150°C
Maximum Storage Temperature Range .....	-65°C to 150°C
Maximum Lead Temperature (Soldering 10s) .....	300°C (SOIC - Lead Tips Only)

**Recommended Operating Area as a Function of Supply Voltage**

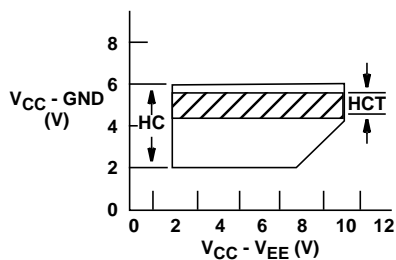

FIGURE 3.

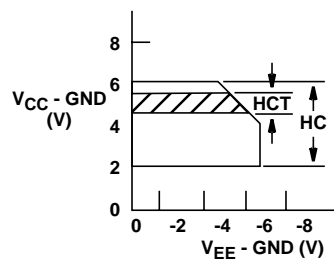

FIGURE 4.

**CD54HC4351, CD74HC4351, CD74HCT4351, CD74HC4352**

**DC Electrical Specifications**

PARAMETER	SYMBOL	TEST CONDITIONS				25°C			-40°C TO 85°C		-55°C TO 125°C		UNITS	
		V <sub>I</sub> (V)	V <sub>IS</sub> (V)	V <sub>EE</sub> (V)	V <sub>CC</sub> (V)	MIN	TYP	MAX	MIN	MAX	MIN	MAX		
<b>HC TYPES</b>														
High Level Input Voltage	V <sub>IH</sub>	-	-	-	2	1.5	-	-	1.5	-	1.5	-	V	
					4.5	3.15	-	-	3.15	-	3.15	-	V	
					6	4.2	-	-	4.2	-	4.2	-	V	
Low Level Input Voltage	V <sub>IL</sub>	-	-	-	2	-	-	0.5	-	0.5	-	0.5	V	
					4.5	-	-	1.35	-	1.35	-	1.35	V	
					6	-	-	1.8	-	1.8	-	1.8	V	
“ON” Resistance I <sub>O</sub> = 1mA Figure 9	R <sub>ON</sub>	V <sub>IH</sub> or V <sub>IL</sub>	V <sub>CC</sub> or V <sub>EE</sub>	0	4.5	-	70	160	-	200	-	240	Ω	
				0	6	-	60	140	-	175	-	210	Ω	
				-4.5	4.5	-	40	120	-	150	-	180	Ω	
			V <sub>CC</sub> to V <sub>EE</sub>	0	4.5	-	90	180	-	225	-	270	Ω	
				0	6	-	80	160	-	200	-	240	Ω	
				-4.5	4.5	-	45	130	-	162	-	195	Ω	
Maximum “ON” Resistance Between Any Two Channels	ΔR <sub>ON</sub>	-	-	0	4.5	-	10	-	-	-	-	-	Ω	
				0	6	-	8.5	-	-	-	-	-	Ω	
				-4.5	4.5	-	5	-	-	-	-	-	Ω	
Switch On/Off Leakage Current 4 Channels (4352)	I <sub>IZ</sub>	V <sub>IH</sub> or V <sub>IL</sub>	For Switch OFF: When V <sub>IS</sub> = V <sub>CC</sub> V <sub>OS</sub> = V <sub>EE</sub> ; When V <sub>IS</sub> = V <sub>EE</sub> ; V <sub>OS</sub> = V <sub>CC</sub> For Switch ON: All Applicable Combinations of V <sub>IS</sub> and V <sub>OS</sub> Voltage Levels	0	6	-	-	±0.1	-	±1	-	±1	μA	
				-5	5	-	-	±0.2	-	±2	-	±2	μA	
Switch On/Off Leakage Current 8 Channels (4351)	I <sub>IZ</sub>	V <sub>IH</sub> or V <sub>IL</sub>		0	6	-	-	±0.2	-	±2	-	±2	μA	
				-5	5	-	-	±0.4	-	±4	-	±4	μA	
Control Input Leakage Current	I <sub>IL</sub>	V <sub>CC</sub> or GND		-	0	6	-	-	±0.1	-	±1	-	±1	μA
Quiescent Device Current I <sub>O</sub> = 0	I <sub>CC</sub>	V <sub>CC</sub> or GND		When V <sub>IS</sub> = V <sub>EE</sub> ; V <sub>OS</sub> = V <sub>CC</sub> ; When V <sub>IS</sub> = V <sub>CC</sub> ; V <sub>OS</sub> = V <sub>EE</sub>	0	6	-	-	8	-	80	-	160	μA
			-5		5	-	-	16	-	160	-	320	μA	

**CD54HC4351, CD74HC4351, CD74HCT4351, CD74HC4352**

**DC Electrical Specifications (Continued)**

PARAMETER	SYMBOL	TEST CONDITIONS				25°C			-40°C TO 85°C		-55°C TO 125°C		UNITS
		V <sub>I</sub> (V)	V <sub>IS</sub> (V)	V <sub>EE</sub> (V)	V <sub>CC</sub> (V)	MIN	TYP	MAX	MIN	MAX	MIN	MAX	
<b>HCT TYPES</b>													
High Level Input Voltage	V <sub>IH</sub>	-	-	-	4.5 to 5.5	2	-	-	2	-	2	-	V
Low Level Input Voltage	V <sub>IL</sub>	-	-	-	4.5 to 5.5	-	-	0.8	-	0.8	-	0.8	V
“ON” Resistance I <sub>O</sub> = 1mA Figure 9	R <sub>ON</sub>	V <sub>IH</sub> or V <sub>IL</sub>	V <sub>CC</sub> or V <sub>EE</sub>	0	4.5	-	70	160	-	200	-	240	Ω
				-4.5	4.5	-	40	120	-	150	-	180	Ω
		V <sub>CC</sub> to V <sub>EE</sub>	0	4.5	-	90	180	-	225	-	270	Ω	
			-4.5	4.5	-	45	130	-	162	-	195	Ω	
Maximum “ON” Resistance Between Any Two Channels	ΔR <sub>ON</sub>	-	-	0	4.5	-	10	-	-	-	-	-	Ω
				-4.5	4.5	-	5	-	-	-	-	-	-
Switch On/Off Leakage Current 4 Channels (4352)	I <sub>IZ</sub>	V <sub>IH</sub> or V <sub>IL</sub>	For Switch OFF: When V <sub>IS</sub> = V <sub>CC</sub> V <sub>OS</sub> = V <sub>EE</sub> ; When V <sub>IS</sub> = V <sub>EE</sub> , V <sub>OS</sub> = V <sub>CC</sub> For Switch ON: All Applicable Combinations of V <sub>IS</sub> and V <sub>OS</sub> Voltage Levels	0	6	-	-	±0.1	-	±1	-	±1	μA
-5				5	-	-	±0.2	-	±2	-	±2	μA	
0				6	-	-	±0.2	-	±2	-	±2	μA	
-5				5	-	-	±0.4	-	±4	-	±4	μA	
Switch On/Off Leakage Current 8 Channels (4351)													
Control Input Leakage Current	I <sub>I</sub>	V <sub>CC</sub> or GND	-	0	5.5	-	-	±0.1	-	±1	-	±1	μA
Quiescent Device Current I <sub>O</sub> = 0	I <sub>CC</sub>	Any Voltage Between V <sub>CC</sub> and GND	When V <sub>IS</sub> = V <sub>EE</sub> , V <sub>OS</sub> = V <sub>CC</sub> ; When V <sub>IS</sub> = V <sub>CC</sub> , V <sub>OS</sub> = V <sub>EE</sub>	0	5.5	-	-	8	-	80	-	160	μA
				-4.5	5.5	-	-	16	-	160	-	320	μA
Additional Quiescent Device Current Per Input Pin: 1 Unit Load	ΔI <sub>CC</sub> (Note 5)	V <sub>CC</sub> -2.1	-	-	4.5 to 5.5	-	100	360	-	450	-	490	μA

NOTE:

5. For dual-supply systems theoretical worst case (V<sub>I</sub> = 2.4V, V<sub>CC</sub> = 5.5V) specification is 1.8mA.

**HCT Input Loading Table**

TYPE	INPUT	UNIT LOADS
All	$\overline{E}1, E2, Sn$	0.5
(4351, 4352)	$\overline{LE}$	1.5

NOTE: Unit Load is ΔI<sub>CC</sub> limit specified in DC Electrical Table, e.g., 360μA max at 25°C.

**CD54HC4351, CD74HC4351, CD74HCT4351, CD74HC4352**

**Switching Specifications** Input  $t_r, t_f = 6\text{ns}$

PARAMETER	SYMBOL	TEST CONDITIONS	$V_{EE}$ (V)	$V_{CC}$ (V)	25°C			-40°C TO 85°C		-55°C TO 125°C		UNITS
					MIN	TYP	MAX	MIN	MAX	MIN	MAX	
<b>HC TYPES</b>												
Propagation Delay, Switch In to Switch Out	$t_{PLH}, t_{PHL}$	$C_L = 50\text{pF}$	0	2	-	-	35	-	45	-	55	ns
			0	4.5	-	-	7	-	9	-	11	ns
			0	6	-	-	6	-	8	-	9	ns
			-4.5	4.5	-	-	5	-	7	-	8	ns
Maximum Switch Turn "ON" Delay 4351 $\bar{E}1, E2, \bar{L}E$ to $V_{OS}$	$t_{PZH}, t_{PZL}$	$C_L = 50\text{pF}$	0	2	-	-	300	-	375	-	450	ns
			0	4.5	-	-	60	-	75	-	90	ns
			0	6	-	-	51	-	64	-	77	ns
			-4.5	4.5	-	-	55	-	69	-	83	ns
		$C_L = 15\text{pF}$	-	5	-	27	-	-	-	-	-	ns
Maximum Switch Turn "ON" Delay 4352 $\bar{E}1, E2, \bar{L}E$ to $V_{OS}$	$t_{PZH}, t_{PZL}$	$C_L = 50\text{pF}$	0	2	-	-	350	-	440	-	525	ns
			0	4.5	-	-	70	-	88	-	105	ns
			0	6	-	-	60	-	75	-	90	ns
			-4.5	4.5	-	-	60	-	75	-	90	ns
		$C_L = 15\text{pF}$	-	5	-	35	-	-	-	-	-	ns
Maximum Switch Turn "ON" Delay 4351 $S_n$ to $V_{OS}$	$t_{PZH}, t_{PZL}$	$C_L = 50\text{pF}$	0	2	-	-	300	-	375	-	450	ns
			0	4.5	-	-	60	-	75	-	90	ns
			0	6	-	-	51	-	64	-	77	ns
			-4.5	4.5	-	-	50	-	63	-	75	ns
		$C_L = 15\text{pF}$	-	5	-	27	-	-	-	-	-	ns
Maximum Switch Turn "ON" Delay 4352 $S_n$ to $V_{OS}$	$t_{PZH}, t_{PZL}$	$C_L = 50\text{pF}$	0	2	-	-	375	-	470	-	565	ns
			0	4.5	-	-	75	-	94	-	113	ns
			0	6	-	-	64	-	80	-	96	ns
			-4.5	4.5	-	-	55	-	69	-	83	ns
		$C_L = 15\text{pF}$	-	5	-	35	-	-	-	-	-	ns
Maximum Switch Turn "OFF" Delay 4351 $\bar{E}1$ to $V_{OS}$	$t_{PHZ}, t_{PLZ}$	$C_L = 50\text{pF}$	0	2	-	-	250	-	315	-	375	ns
			0	4.5	-	-	50	-	63	-	75	ns
			0	6	-	-	43	-	54	-	64	ns
			-4.5	4.5	-	-	40	-	50	-	60	ns
		$C_L = 15\text{pF}$	-	5	-	21	-	-	-	-	-	ns

**CD54HC4351, CD74HC4351, CD74HCT4351, CD74HC4352**

**Switching Specifications** Input  $t_r$ ,  $t_f = 6\text{ns}$  (Continued)

PARAMETER	SYMBOL	TEST CONDITIONS	V <sub>EE</sub> (V)	V <sub>CC</sub> (V)	25°C			-40°C TO 85°C		-55°C TO 125°C		UNITS
					MIN	TYP	MAX	MIN	MAX	MIN	MAX	
Maximum Switch Turn "OFF" Delay 4351 E2 to V <sub>OS</sub>	t <sub>PHZ</sub> , t <sub>PLZ</sub>	C <sub>L</sub> = 50pF	0	2	-	-	250	-	315	-	375	ns
			0	4.5	-	-	50	-	63	-	75	ns
			0	6	-	-	43	-	54	-	64	ns
			-4.5	4.5	-	-	40	-	50	-	60	ns
		C <sub>L</sub> = 15pF	-	5	-	21	-	-	-	-	-	ns
Maximum Switch Turn "OFF" Delay 4351 LE to V <sub>OS</sub>	t <sub>PHZ</sub> , t <sub>PLZ</sub>	C <sub>L</sub> = 50pF	0	2	-	-	275	-	345	-	415	ns
			0	4.5	-	-	55	-	69	-	83	ns
			0	6	-	-	47	-	59	-	71	ns
			-4.5	4.5	-	-	45	-	56	-	68	ns
		C <sub>L</sub> = 15pF	-	5	-	21	-	-	-	-	-	ns
Maximum Switch Turn "OFF" Delay 4351 Sn to V <sub>OS</sub>	t <sub>PHZ</sub> , t <sub>PLZ</sub>	C <sub>L</sub> = 50pF	0	2	-	-	275	-	345	-	415	ns
			0	4.5	-	-	55	-	69	-	83	ns
			0	6	-	-	47	-	59	-	71	ns
			-4.5	4.5	-	-	48	-	60	-	71	ns
		C <sub>L</sub> = 15pF	-	5	-	21	-	-	-	-	-	ns
Maximum Switch Turn "OFF" Delay 4352 E1, E2, LE to V <sub>OS</sub>	t <sub>PHZ</sub> , t <sub>PLZ</sub>	C <sub>L</sub> = 50pF	0	2	-	-	275	-	345	-	415	ns
			0	4.5	-	-	55	-	69	-	83	ns
			0	6	-	-	47	-	59	-	71	ns
			-4.5	4.5	-	-	50	-	63	-	75	ns
		C <sub>L</sub> = 15pF	-	5	-	21	-	-	-	-	-	ns
Setup Time 4351 Sn to LE	t <sub>SU</sub>	C <sub>L</sub> = 50pF	0	2	-	-	60	-	75	-	90	ns
			0	4.5	-	-	12	-	15	-	18	ns
			0	6	-	-	10	-	13	-	15	ns
			-4.5	4.5	-	-	18	-	23	-	27	ns
			C <sub>L</sub> = 15pF	-	5	-	21	-	-	-	-	-
Hold Time 4351 and 4352 Sn to LE	t <sub>H</sub>	C <sub>L</sub> = 50pF	0	2	5	-	-	5	-	5	-	ns
			0	4.5	5	-	-	5	-	5	-	ns
			0	6	5	-	-	5	-	5	-	ns
			-4.5	4.5	5	-	-	5	-	5	-	ns
			C <sub>L</sub> = 15pF	-	5	-	21	-	-	-	-	-
Pulse Width 4351 and 4352 LE	t <sub>W</sub>	C <sub>L</sub> = 50pF	0	2	100	-	-	125	-	150	-	ns
			0	4.5	20	-	-	25	-	30	-	ns
			0	6	17	-	-	21	-	26	-	ns
			-4.5	4.5	25	-	-	31	-	38	-	ns
			C <sub>L</sub> = 15pF	-	5	-	21	-	-	-	-	-
Input (Control) Capacitance	C <sub>I</sub>	-	-	-	-	10	-	10	-	10	pF	
Power Dissipation Capacitance (Notes 6, 7) 4351	C <sub>PD</sub>	-	-	5	-	50	-	-	-	-	pF	

**CD54HC4351, CD74HC4351, CD74HCT4351, CD74HC4352**

**Switching Specifications** Input  $t_r, t_f = 6\text{ns}$  (Continued)

PARAMETER	SYMBOL	TEST CONDITIONS	V <sub>EE</sub> (V)	V <sub>CC</sub> (V)	25°C			-40°C TO 85°C		-55°C TO 125°C		UNITS
					MIN	TYP	MAX	MIN	MAX	MIN	MAX	
Power Dissipation Capacitance (Notes 6, 7) 4352	C <sub>PD</sub>	-	-	5	-	74	-	-	-	-	-	pF
<b>HCT TYPES</b>												
Propagation Delay, Switch In to Switch Out	t <sub>PLH</sub> , t <sub>PHL</sub>	C <sub>L</sub> = 50pF	0	4.5	-	-	7	-	9	-	11	ns
			-4.5	4.5	-	-	5	-	7	-	8	ns
Maximum Switch Turn "ON" Delay 4351 E <sub>1</sub> , E <sub>2</sub> , LE to V <sub>OS</sub>	t <sub>PZH</sub> , t <sub>PZL</sub>	C <sub>L</sub> = 50pF	0	4.5	-	-	75	-	94	-	113	ns
			-4.5	4.5	-	-	60	-	75	-	90	ns
		C <sub>L</sub> = 15pF	-	5	-	35	-	-	-	-	-	ns
Maximum Switch Turn "ON" Delay 4351 Sn to V <sub>OS</sub>	t <sub>PZH</sub> , t <sub>PZL</sub>	C <sub>L</sub> = 50pF	0	4.5	-	-	75	-	94	-	113	ns
			-4.5	4.5	-	-	60	-	75	-	90	ns
		C <sub>L</sub> = 15pF	-	5	-	35	-	-	-	-	-	ns
Maximum Switch Turn "OFF" Delay 4351 E <sub>1</sub> to V <sub>OS</sub>	t <sub>PHZ</sub> , t <sub>PLZ</sub>	C <sub>L</sub> = 50pF	0	4.5	-	-	55	-	69	-	83	ns
			-4.5	4.5	-	-	40	-	50	-	60	ns
		C <sub>L</sub> = 15pF	-	5	-	23	-	-	-	-	-	ns
Maximum Switch Turn "OFF" Delay 4351 E <sub>2</sub> to V <sub>OS</sub>	t <sub>PHZ</sub> , t <sub>PLZ</sub>	C <sub>L</sub> = 50pF	0	4.5	-	-	60	-	75	-	90	ns
			-4.5	4.5	-	-	50	-	63	-	75	ns
		C <sub>L</sub> = 15pF	-	5	-	23	-	-	-	-	-	ns
Maximum Switch Turn "OFF" Delay 4351 LE to V <sub>OS</sub>	t <sub>PHZ</sub> , t <sub>PLZ</sub>	C <sub>L</sub> = 50pF	0	4.5	-	-	60	-	75	-	90	ns
			-4.5	4.5	-	-	55	-	69	-	83	ns
		C <sub>L</sub> = 15pF	-	5	-	23	-	-	-	-	-	ns
Maximum Switch Turn "OFF" Delay 4351 Sn to V <sub>OS</sub>	t <sub>PHZ</sub> , t <sub>PLZ</sub>	C <sub>L</sub> = 50pF	0	4.5	-	-	65	-	81	-	98	ns
			-4.5	4.5	-	-	55	-	69	-	83	ns
		C <sub>L</sub> = 15pF	-	5	-	23	-	-	-	-	-	ns
Setup Time 4351 Sn to LE		C <sub>L</sub> = 50pF	0	4.5	-	-	12	-	15	-	18	ns
			-4.5	4.5	-	-	14	-	18	-	21	ns
Hold Time 4351 and 4352 Sn to LE		C <sub>L</sub> = 50pF	0	4.5	5	-	-	5	-	5	-	ns
			-4.5	4.5	5	-	-	5	-	5	-	ns
Pulse Width 4351 LE	t <sub>W</sub>	C <sub>L</sub> = 50pF	0	4.5	25	-	-	31	-	28	-	ns
			-4.5	4.5	25	-	-	31	-	38	-	ns
Input (Control) Capacitance	C <sub>I</sub>	-	-	-	-	-	10	-	10	-	10	pF
Power Dissipation Capacitance (Notes 6, 7) 4351	C <sub>PD</sub>	-	-	5	-	52	-	-	-	-	-	pF

**NOTES:**

6. C<sub>PD</sub> is used to determine the dynamic power consumption, per package.

7.  $P_D = C_{PD} V_{CC}^2 f_i + \sum (C_L + C_S) V_{CC}^2 f_o$  where  $f_i$  = input frequency,  $f_o$  = output frequency,  $C_L$  = output load capacitance,  $C_S$  = switch capacitance,  $V_{CC}$  = supply voltage.

**CD54HC4351, CD74HC4351, CD74HCT4351, CD74HC4352**

**Analog Channel Specifications**  $T_A = 25^\circ\text{C}$

PARAMETER	SYMBOL	TEST CONDITIONS	TYPE	$V_{EE}$ (V)	$V_{CC}$ (V)	HC/HCT	UNITS
Switch Input Capacitance	$C_I$		All	-	-	5	pF
Common Capacitance	$C_{COM}$		4351	-	-	25	pF
			4352	-	-	12	pF
Minimum Switch Frequency Response at -3dB (Figure 6, 8)	$f_{MAX}$	See Figure 11 (Notes 8, 9)	4351	-	-	145	MHz
			4352	-2.25	2.25	165	MHz
			4351	-	-	180	MHz
			4352	-4.5	4.5	185	MHz
Crosstalk Between Any Two Switches (Note 11)		See Figure 10 (Notes 9, 10)	4351	-	-	N/A	dB
			4352	-2.25	2.25	(TBE)	dB
			4351	-	-	N/A	dB
			4352	-4.5	4.5	(TBE)	dB
Sine-Wave Distortion		See Figure 12	All	-2.25	2.25	0.035	%
			All	-4.5	4.5	0.018	%
$\bar{E}$ or S to Switch Feedthrough Noise		See Figure 13 (Notes 9, 10)	4351	-	-	-	mV
			4352	-2.25	2.25	(TBE)	mV
			4351	-	-	-	mV
			4352	-4.5	4.5	(TBE)	mV
Switch "OFF" Signal Feedthrough (Figure 6, 8)		See Figure 14 (Notes 9, 10)	4351	-	-	-73	dB
			4352	-2.25	2.25	-65	dB
			4351	-	-	-75	dB
			4352	-4.5	4.5	-67	dB

**NOTES:**

8. Adjust input voltage to obtain 0dBm at  $V_{OS}$  for,  $f_{in} = 1\text{MHz}$ .
9.  $V_{IS}$  is centered at  $(V_{CC} - V_{EE})/2$ .
10. Adjust input for 0dBm.
11. Not applicable for 'HC4351 and CD74HCT4351.

Typical Performance Curves

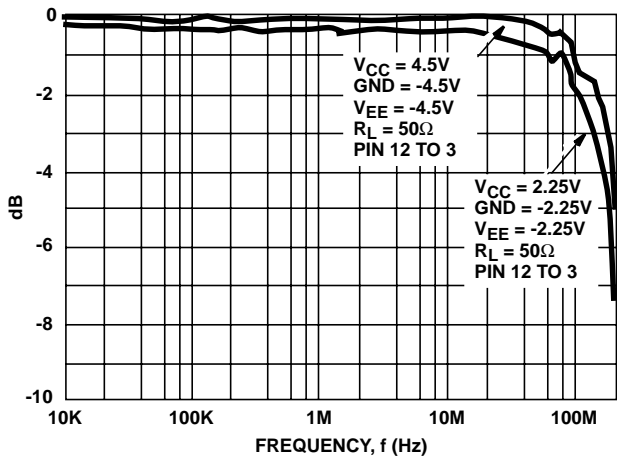

FIGURE 5. CHANNEL ON BANDWIDTH ('HC4351, CD74HCT4351)

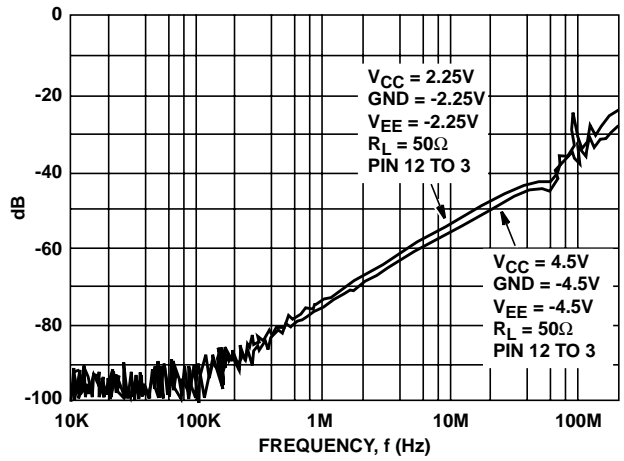

FIGURE 6. CHANNEL OFF FEEDTHROUGH ('HC4351, CD74HCT4351)

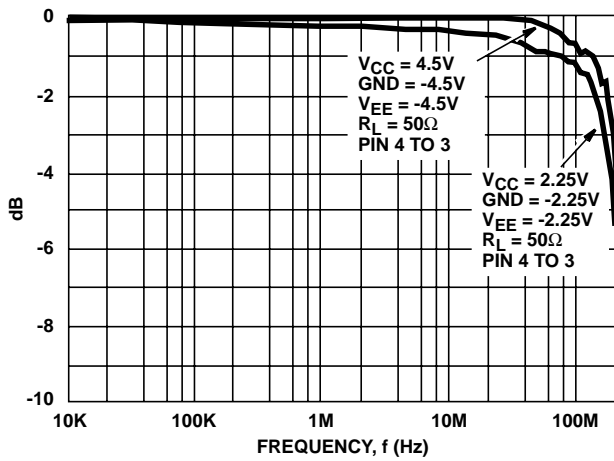

FIGURE 7. CHANNEL ON BANDWIDTH (CD74HC4352)

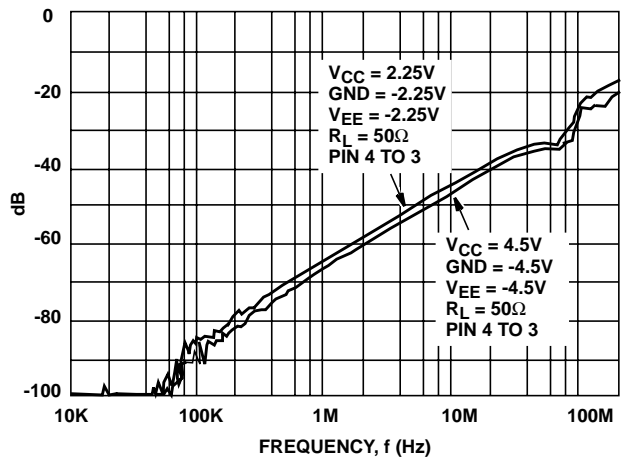

FIGURE 8. CHANNEL OFF FEEDTHROUGH (CD74HC4352)

Typical Performance Curves (Continued)

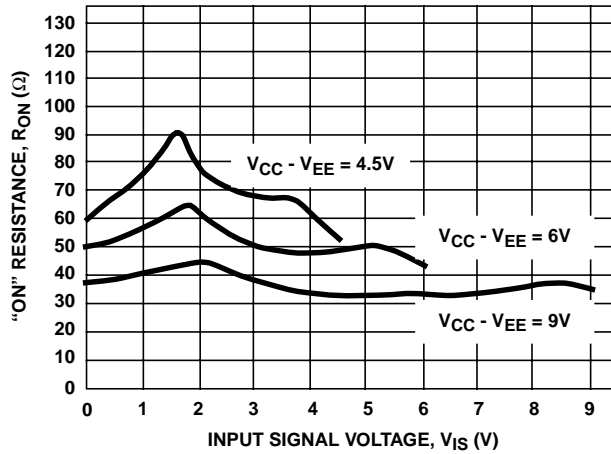

FIGURE 9. TYPICAL ON RESISTANCE vs INPUT SIGNAL VOLTAGE

Analog Test Circuits

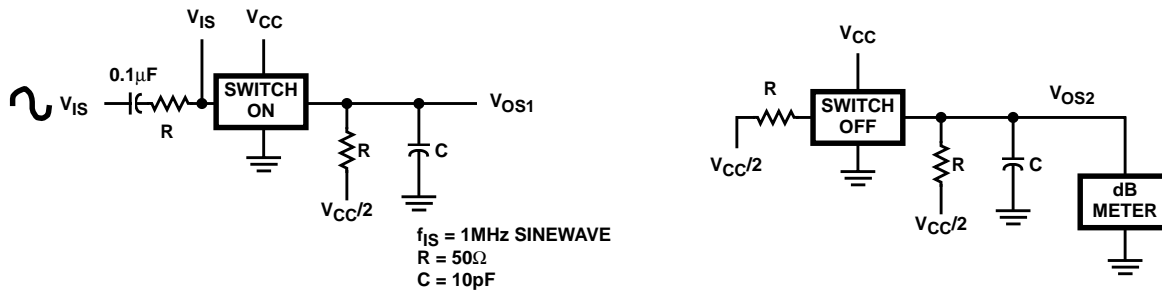

FIGURE 10. CROSTALK BETWEEN TWO SWITCHES TEST CIRCUIT

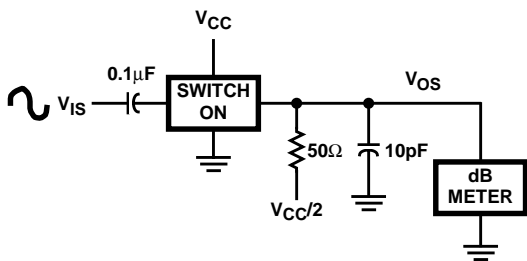

FIGURE 11. FREQUENCY RESPONSE TEST CIRCUIT

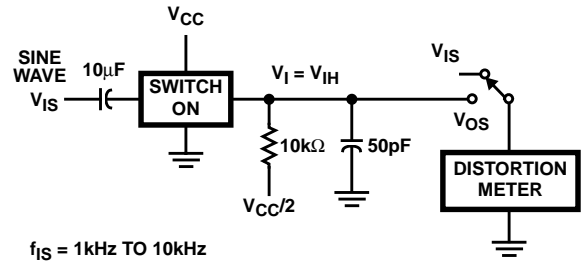

FIGURE 12. TOTAL HARMONIC DISTORTION TEST CIRCUIT

Analog Test Circuits (Continued)

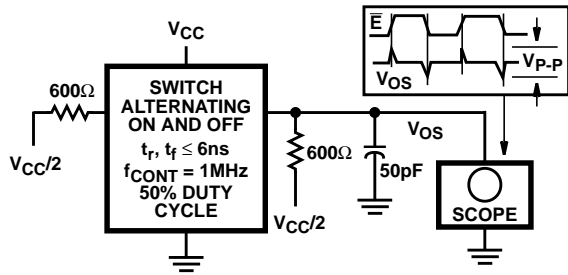

FIGURE 13. CONTROL-TO-SWITCH FEEDTHROUGH NOISE TEST CIRCUIT

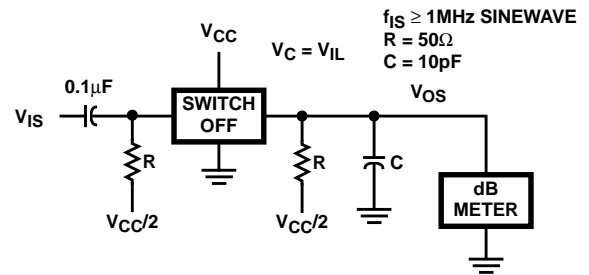
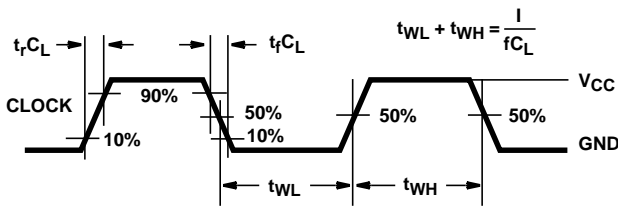

FIGURE 14. SWITCH OFF SIGNAL FEEDTHROUGH

Test Circuits and Waveforms



NOTE: Outputs should be switching from 10%  $V_{CC}$  to 90%  $V_{CC}$  in accordance with device truth table. For  $f_{MAX}$ , input duty cycle = 50%.

FIGURE 15. HC CLOCK PULSE RISE AND FALL TIMES AND PULSE WIDTH

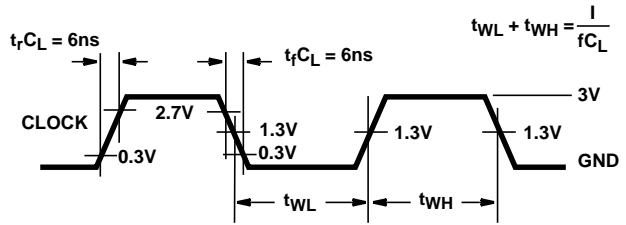

NOTE: Outputs should be switching from 10%  $V_{CC}$  to 90%  $V_{CC}$  in accordance with device truth table. For  $f_{MAX}$ , input duty cycle = 50%.

FIGURE 16. HCT CLOCK PULSE RISE AND FALL TIMES AND PULSE WIDTH

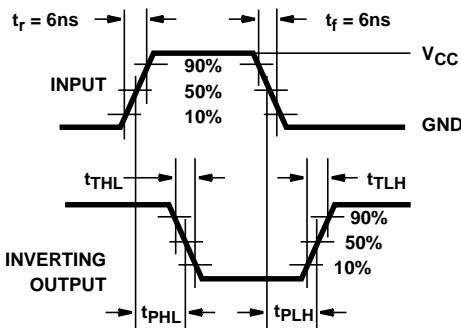

FIGURE 17. HC TRANSITION TIMES AND PROPAGATION DELAY TIMES, COMBINATION LOGIC

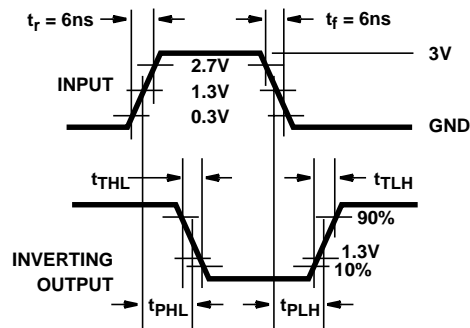

FIGURE 18. HCT TRANSITION TIMES AND PROPAGATION DELAY TIMES, COMBINATION LOGIC

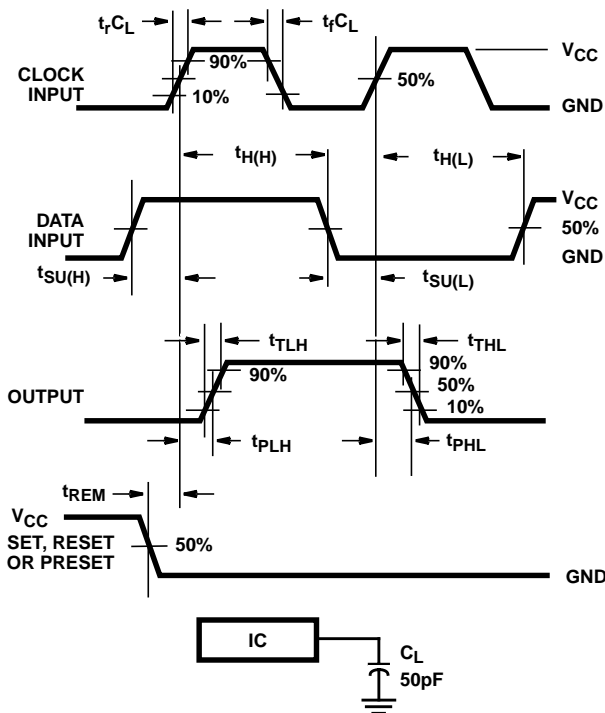

FIGURE 19. HC SETUP TIMES, HOLD TIMES, REMOVAL TIME, AND PROPAGATION DELAY TIMES FOR EDGE TRIGGERED SEQUENTIAL LOGIC CIRCUITS

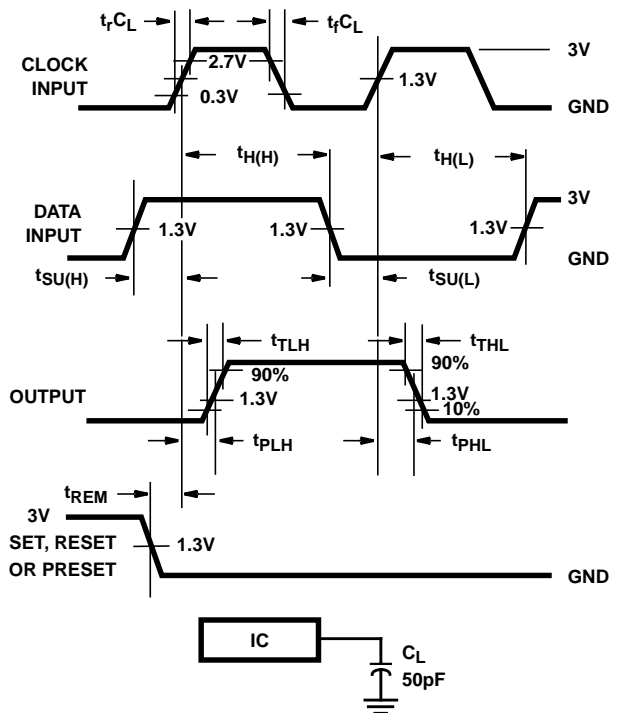

FIGURE 20. HCT SETUP TIMES, HOLD TIMES, REMOVAL TIME, AND PROPAGATION DELAY TIMES FOR EDGE TRIGGERED SEQUENTIAL LOGIC CIRCUITS

**Test Circuits and Waveforms** (Continued)

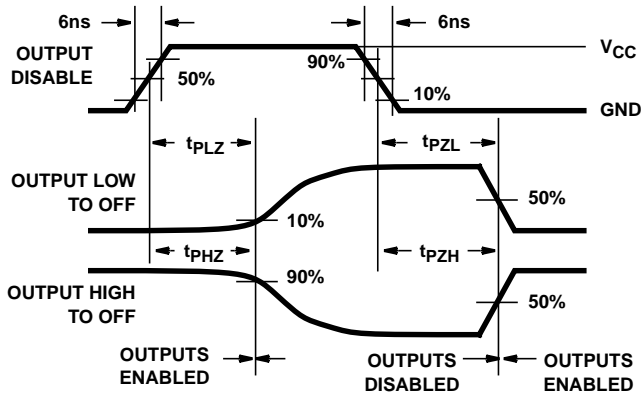

FIGURE 21. HC THREE-STATE PROPAGATION DELAY WAVEFORM

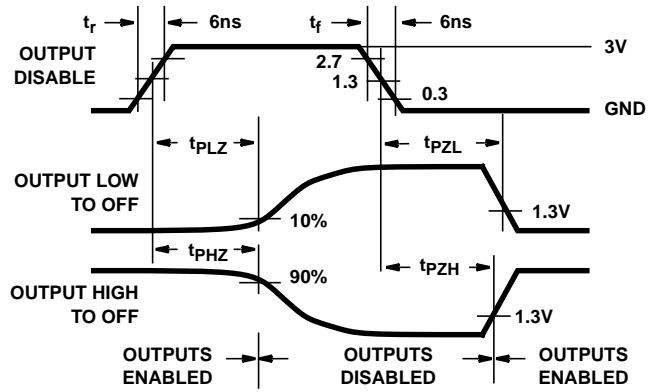
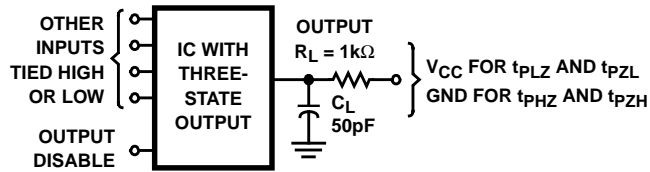

FIGURE 22. HCT THREE-STATE PROPAGATION DELAY WAVEFORM



NOTE: Open drain waveforms  $t_{PLZ}$  and  $t_{PZL}$  are the same as those for three-state shown on the left. The test circuit is Output  $R_L = 1k\Omega$  to  $V_{CC}$ ,  $C_L = 50pF$ .

FIGURE 23. HC AND HCT THREE-STATE PROPAGATION DELAY TEST CIRCUIT

**PACKAGING INFORMATION**

Orderable Device	Status <sup>(1)</sup>	Package Type	Package Drawing	Pins	Package Qty	Eco Plan <sup>(2)</sup>	Lead/Ball Finish	MSL Peak Temp <sup>(3)</sup>
CD54HC4351F3A	ACTIVE	CDIP	J	20	1	TBD	A42	N / A for Pkg Type
CD74HC4351E	ACTIVE	PDIP	N	20	20	Pb-Free (RoHS)	CU NIPDAU	N / A for Pkg Type
CD74HC4351EE4	ACTIVE	PDIP	N	20	20	Pb-Free (RoHS)	CU NIPDAU	N / A for Pkg Type
CD74HC4351M	ACTIVE	SOIC	DW	20	25	Green (RoHS & no Sb/Br)	CU NIPDAU	Level-1-260C-UNLIM
CD74HC4351M96	ACTIVE	SOIC	DW	20	2000	Green (RoHS & no Sb/Br)	CU NIPDAU	Level-1-260C-UNLIM
CD74HC4351M96E4	ACTIVE	SOIC	DW	20	2000	Green (RoHS & no Sb/Br)	CU NIPDAU	Level-1-260C-UNLIM
CD74HC4351M96G4	ACTIVE	SOIC	DW	20	2000	Green (RoHS & no Sb/Br)	CU NIPDAU	Level-1-260C-UNLIM
CD74HC4351ME4	ACTIVE	SOIC	DW	20	25	Green (RoHS & no Sb/Br)	CU NIPDAU	Level-1-260C-UNLIM
CD74HC4351MG4	ACTIVE	SOIC	DW	20	25	Green (RoHS & no Sb/Br)	CU NIPDAU	Level-1-260C-UNLIM
CD74HC4352E	ACTIVE	PDIP	N	20	20	Pb-Free (RoHS)	CU NIPDAU	N / A for Pkg Type
CD74HC4352EE4	ACTIVE	PDIP	N	20	20	Pb-Free (RoHS)	CU NIPDAU	N / A for Pkg Type
CD74HCT4351E	ACTIVE	PDIP	N	20	20	Pb-Free (RoHS)	CU NIPDAU	N / A for Pkg Type
CD74HCT4351EE4	ACTIVE	PDIP	N	20	20	Pb-Free (RoHS)	CU NIPDAU	N / A for Pkg Type

<sup>(1)</sup> The marketing status values are defined as follows:

**ACTIVE:** Product device recommended for new designs.

**LIFEBUY:** TI has announced that the device will be discontinued, and a lifetime-buy period is in effect.

**NRND:** Not recommended for new designs. Device is in production to support existing customers, but TI does not recommend using this part in a new design.

**PREVIEW:** Device has been announced but is not in production. Samples may or may not be available.

**OBSOLETE:** TI has discontinued the production of the device.

<sup>(2)</sup> Eco Plan - The planned eco-friendly classification: Pb-Free (RoHS), Pb-Free (RoHS Exempt), or Green (RoHS & no Sb/Br) - please check <http://www.ti.com/productcontent> for the latest availability information and additional product content details.

**TBD:** The Pb-Free/Green conversion plan has not been defined.

**Pb-Free (RoHS):** TI's terms "Lead-Free" or "Pb-Free" mean semiconductor products that are compatible with the current RoHS requirements for all 6 substances, including the requirement that lead not exceed 0.1% by weight in homogeneous materials. Where designed to be soldered at high temperatures, TI Pb-Free products are suitable for use in specified lead-free processes.

**Pb-Free (RoHS Exempt):** This component has a RoHS exemption for either 1) lead-based flip-chip solder bumps used between the die and package, or 2) lead-based die adhesive used between the die and leadframe. The component is otherwise considered Pb-Free (RoHS compatible) as defined above.

**Green (RoHS & no Sb/Br):** TI defines "Green" to mean Pb-Free (RoHS compatible), and free of Bromine (Br) and Antimony (Sb) based flame retardants (Br or Sb do not exceed 0.1% by weight in homogeneous material)

<sup>(3)</sup> MSL, Peak Temp. -- The Moisture Sensitivity Level rating according to the JEDEC industry standard classifications, and peak solder temperature.

**Important Information and Disclaimer:** The information provided on this page represents TI's knowledge and belief as of the date that it is provided. TI bases its knowledge and belief on information provided by third parties, and makes no representation or warranty as to the accuracy of such information. Efforts are underway to better integrate information from third parties. TI has taken and continues to take reasonable steps to provide representative and accurate information but may not have conducted destructive testing or chemical analysis on incoming materials and chemicals. TI and TI suppliers consider certain information to be proprietary, and thus CAS numbers and other limited

information may not be available for release.

In no event shall TI's liability arising out of such information exceed the total purchase price of the TI part(s) at issue in this document sold by TI to Customer on an annual basis.

**TAPE AND REEL INFORMATION**



**QUADRANT ASSIGNMENTS FOR PIN 1 ORIENTATION IN TAPE**



\*All dimensions are nominal

Device	Package Type	Package Drawing	Pins	SPQ	Reel Diameter (mm)	Reel Width W1 (mm)	A0 (mm)	B0 (mm)	K0 (mm)	P1 (mm)	W (mm)	Pin1 Quadrant
CD74HC4351M96	SOIC	DW	20	2000	330.0	24.4	10.8	13.0	2.7	12.0	24.0	Q1

**TAPE AND REEL BOX DIMENSIONS**



\*All dimensions are nominal

Device	Package Type	Package Drawing	Pins	SPQ	Length (mm)	Width (mm)	Height (mm)
CD74HC4351M96	SOIC	DW	20	2000	346.0	346.0	41.0



N (R-PDIP-T\*\*)

PLASTIC DUAL-IN-LINE PACKAGE

16 PINS SHOWN



- NOTES:
- A. All linear dimensions are in inches (millimeters).
  - B. This drawing is subject to change without notice.
  - Falls within JEDEC MS-001, except 18 and 20 pin minimum body length (Dim A).
  - The 20 pin end lead shoulder width is a vendor option, either half or full width.

DW (R-PDSO-G20)

PLASTIC SMALL OUTLINE

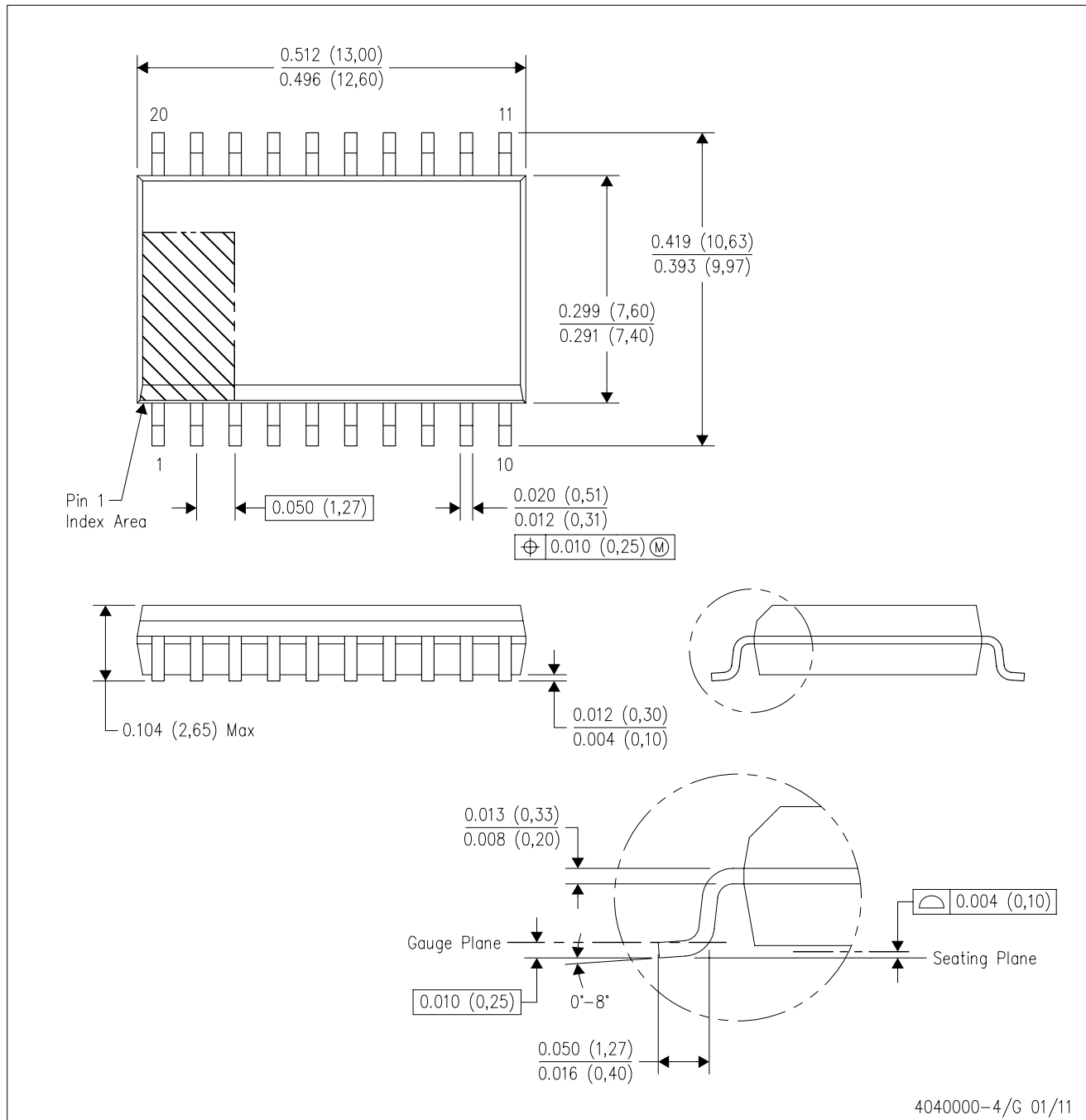

- NOTES:
- A. All linear dimensions are in inches (millimeters). Dimensioning and tolerancing per ASME Y14.5M-1994.
  - B. This drawing is subject to change without notice.
  - C. Body dimensions do not include mold flash or protrusion not to exceed 0.006 (0,15).
  - D. Falls within JEDEC MS-013 variation AC.

DW (R-PDSO-G20)

PLASTIC SMALL OUTLINE

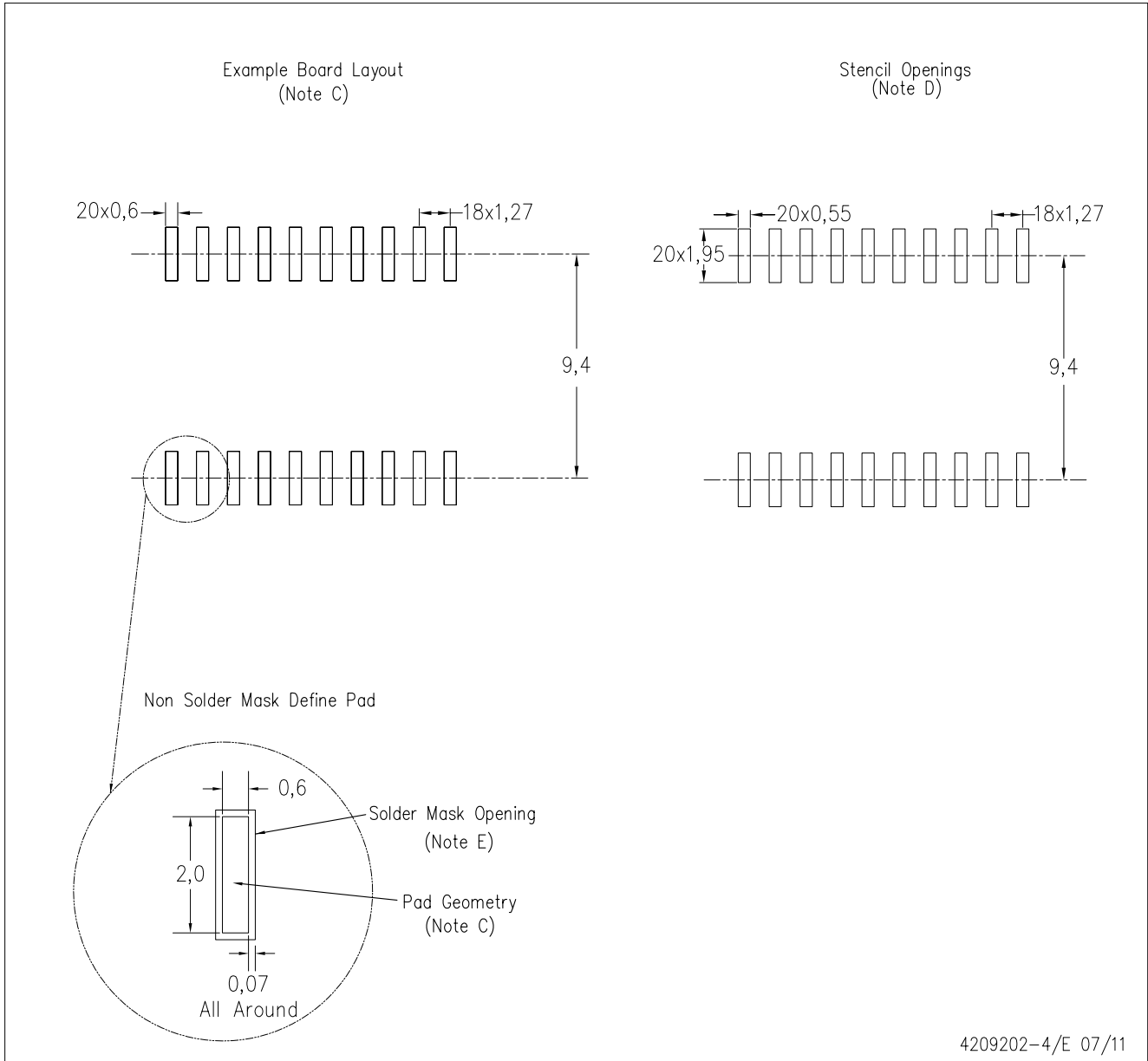

4209202-4/E 07/11

- NOTES:
- A. All linear dimensions are in millimeters.
  - B. This drawing is subject to change without notice.
  - C. Refer to IPC7351 for alternate board design.
  - D. Laser cutting apertures with trapezoidal walls and also rounding corners will offer better paste release. Customers should contact their board assembly site for stencil design recommendations. Refer to IPC-7525
  - E. Customers should contact their board fabrication site for solder mask tolerances between and around signal pads.

## IMPORTANT NOTICE

Texas Instruments Incorporated and its subsidiaries (TI) reserve the right to make corrections, modifications, enhancements, improvements, and other changes to its products and services at any time and to discontinue any product or service without notice. Customers should obtain the latest relevant information before placing orders and should verify that such information is current and complete. All products are sold subject to TI's terms and conditions of sale supplied at the time of order acknowledgment.

TI warrants performance of its hardware products to the specifications applicable at the time of sale in accordance with TI's standard warranty. Testing and other quality control techniques are used to the extent TI deems necessary to support this warranty. Except where mandated by government requirements, testing of all parameters of each product is not necessarily performed.

TI assumes no liability for applications assistance or customer product design. Customers are responsible for their products and applications using TI components. To minimize the risks associated with customer products and applications, customers should provide adequate design and operating safeguards.

TI does not warrant or represent that any license, either express or implied, is granted under any TI patent right, copyright, mask work right, or other TI intellectual property right relating to any combination, machine, or process in which TI products or services are used. Information published by TI regarding third-party products or services does not constitute a license from TI to use such products or services or a warranty or endorsement thereof. Use of such information may require a license from a third party under the patents or other intellectual property of the third party, or a license from TI under the patents or other intellectual property of TI.

Reproduction of TI information in TI data books or data sheets is permissible only if reproduction is without alteration and is accompanied by all associated warranties, conditions, limitations, and notices. Reproduction of this information with alteration is an unfair and deceptive business practice. TI is not responsible or liable for such altered documentation. Information of third parties may be subject to additional restrictions.

Resale of TI products or services with statements different from or beyond the parameters stated by TI for that product or service voids all express and any implied warranties for the associated TI product or service and is an unfair and deceptive business practice. TI is not responsible or liable for any such statements.

TI products are not authorized for use in safety-critical applications (such as life support) where a failure of the TI product would reasonably be expected to cause severe personal injury or death, unless officers of the parties have executed an agreement specifically governing such use. Buyers represent that they have all necessary expertise in the safety and regulatory ramifications of their applications, and acknowledge and agree that they are solely responsible for all legal, regulatory and safety-related requirements concerning their products and any use of TI products in such safety-critical applications, notwithstanding any applications-related information or support that may be provided by TI. Further, Buyers must fully indemnify TI and its representatives against any damages arising out of the use of TI products in such safety-critical applications.

TI products are neither designed nor intended for use in military/aerospace applications or environments unless the TI products are specifically designated by TI as military-grade or "enhanced plastic." Only products designated by TI as military-grade meet military specifications. Buyers acknowledge and agree that any such use of TI products which TI has not designated as military-grade is solely at the Buyer's risk, and that they are solely responsible for compliance with all legal and regulatory requirements in connection with such use.

TI products are neither designed nor intended for use in automotive applications or environments unless the specific TI products are designated by TI as compliant with ISO/TS 16949 requirements. Buyers acknowledge and agree that, if they use any non-designated products in automotive applications, TI will not be responsible for any failure to meet such requirements.

Following are URLs where you can obtain information on other Texas Instruments products and application solutions:

### Products

Audio	<a href="http://www.ti.com/audio">www.ti.com/audio</a>
Amplifiers	<a href="http://amplifier.ti.com">amplifier.ti.com</a>
Data Converters	<a href="http://dataconverter.ti.com">dataconverter.ti.com</a>
DLP® Products	<a href="http://www.dlp.com">www.dlp.com</a>
DSP	<a href="http://dsp.ti.com">dsp.ti.com</a>
Clocks and Timers	<a href="http://www.ti.com/clocks">www.ti.com/clocks</a>
Interface	<a href="http://interface.ti.com">interface.ti.com</a>
Logic	<a href="http://logic.ti.com">logic.ti.com</a>
Power Mgmt	<a href="http://power.ti.com">power.ti.com</a>
Microcontrollers	<a href="http://microcontroller.ti.com">microcontroller.ti.com</a>
RFID	<a href="http://www.ti-rfid.com">www.ti-rfid.com</a>
RF/IF and ZigBee® Solutions	<a href="http://www.ti.com/lprf">www.ti.com/lprf</a>

### Applications

Communications and Telecom	<a href="http://www.ti.com/communications">www.ti.com/communications</a>
Computers and Peripherals	<a href="http://www.ti.com/computers">www.ti.com/computers</a>
Consumer Electronics	<a href="http://www.ti.com/consumer-apps">www.ti.com/consumer-apps</a>
Energy and Lighting	<a href="http://www.ti.com/energy">www.ti.com/energy</a>
Industrial	<a href="http://www.ti.com/industrial">www.ti.com/industrial</a>
Medical	<a href="http://www.ti.com/medical">www.ti.com/medical</a>
Security	<a href="http://www.ti.com/security">www.ti.com/security</a>
Space, Avionics and Defense	<a href="http://www.ti.com/space-avionics-defense">www.ti.com/space-avionics-defense</a>
Transportation and Automotive	<a href="http://www.ti.com/automotive">www.ti.com/automotive</a>
Video and Imaging	<a href="http://www.ti.com/video">www.ti.com/video</a>
Wireless	<a href="http://www.ti.com/wireless-apps">www.ti.com/wireless-apps</a>

TI E2E Community Home Page

[e2e.ti.com](http://e2e.ti.com)

Mailing Address: Texas Instruments, Post Office Box 655303, Dallas, Texas 75265  
Copyright © 2011, Texas Instruments Incorporated