

CD54HC190, CD74HC190 CD54HC191, CD74HC191, CD54HCT191, CD74HCT191 SYNCHRONOUS UP/DOWN COUNTERS WITH DOWN/UP MODE CONTROL

SCHS275E – MARCH 2002 – REVISED OCTOBER 2003

- 2-V to 6-V V_{CC} Operation ('HC190, 191)
- 4.5-V to 5.5-V V_{CC} Operation ('HCT191)
- Wide Operating Temperature Range of -55°C to 125°C
- Synchronous Counting and Asynchronous Loading
- Two Outputs for n-Bit Cascading
- Look-Ahead Carry for High-Speed Counting
- Balanced Propagation Delays and Transition Times
- Standard Outputs Drive Up To 15 LS-TTL Loads
- Significant Power Reduction Compared to LS-TTL Logic ICs

CD54HC190, 191; CD54HCT191 . . . F PACKAGE
CD74HC190 . . . E, NS, OR PW PACKAGE
CD74HC191, CD74HCT191 . . . E OR M PACKAGE
(TOP VIEW)

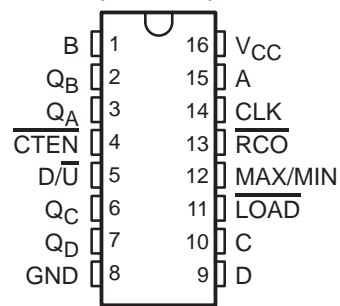

description/ordering information

The CD54/74HC190 are asynchronously presettable BCD decade counters, whereas the CD54/74HC191 and CD54/74HCT191 are asynchronously presettable binary counters.

Presetting the counter to the number on preset data inputs (A–D) is accomplished by a low asynchronous parallel load (LOAD) input. Counting occurs when LOAD is high, count enable (CTEN) is low, and the down/up (D/U) input is either high for down counting or low for up counting. The counter is decremented or incremented synchronously with the low-to-high transition of the clock.

ORDERING INFORMATION

T_A	PACKAGE†		ORDERABLE PART NUMBER	TOP-SIDE MARKING
-55°C to 125°C	PDIP – E	Tube of 25	CD74HC190E	CD74HC190E
			CD74HC191E	CD74HC191E
			CD74HCT191E	CD74HCT191E
	SOIC – M	Tube of 40 Reel of 2500 Reel of 250	CD74HC191M	HC191M
			CD74HC191M96	
			CD74HC191MT	
			Tube of 40	CD74HCT191M
	SOP – NS	Reel of 2000	CD74HC190NSR	HC190M
	TSSOP – PW	Tube of 90	CD74HC190PW	HJ190
		Reel of 2000	CD74HC190PWR	
		Reel of 250	CD74HC190PWT	
	CDIP – F	Tube of 25	CD54HC190F3A	CD54HC190F3A
CD54HC191F3A			CD54HC191F3A	
CD54HCT191F3A			CD54HCT191F3A	

† Package drawings, standard packing quantities, thermal data, symbolization, and PCB design guidelines are available at www.ti.com/sc/package.



Please be aware that an important notice concerning availability, standard warranty, and use in critical applications of Texas Instruments semiconductor products and disclaimers thereto appears at the end of this data sheet.

PRODUCTION DATA information is current as of publication date. Products conform to specifications per the terms of Texas Instruments standard warranty. Production processing does not necessarily include testing of all parameters.

**TEXAS
INSTRUMENTS**

POST OFFICE BOX 655303 • DALLAS, TEXAS 75265

Copyright © 2003, Texas Instruments Incorporated
On products compliant to MIL-PRF-38535, all parameters are tested unless otherwise noted. On all other products, production processing does not necessarily include testing of all parameters.

CD54HC190, CD74HC190
CD54HC191, CD74HC191, CD54HCT191, CD74HCT191
SYNCHRONOUS UP/DOWN COUNTERS WITH DOWN/UP MODE CONTROL



SCHS275E – MARCH 2002 – REVISED OCTOBER 2003

description/ordering information (continued)

When an overflow or underflow of the counter occurs, the MAX/MIN output, which is low during counting, goes high and remains high for one clock cycle. This output can be used for look-ahead carry in high-speed cascading (see Figure 1). The MAX/MIN output also initiates the ripple clock (\overline{RCO}) output, which normally is high, goes low, and remains low for the low-level portion of the clock pulse. These counters can be cascaded using \overline{RCO} (see Figure 2).

If a decade counter is preset to an illegal state or assumes an illegal state when power is applied, it returns to the normal sequence in one or two counts, as shown in the state diagrams (see Figure 3).

FUNCTION TABLE

INPUTS				FUNCTION
\overline{LOAD}	\overline{CTEN}	D/\overline{U}	CLK	
H	L	L		Count up
H	L	H		Count down
L	X	X	X	Asynchronous preset
H	H	X	X	No change

$\overline{D/\overline{U}}$ or \overline{CTEN} should be changed only when clock is high.

X = Don't care

 Low-to-high clock transition

CD54HC190, CD74HC190
CD54HC191, CD74HC191, CD54HCT191, CD74HCT191
SYNCHRONOUS UP/DOWN COUNTERS WITH DOWN/UP MODE CONTROL

SCHS275E – MARCH 2002 – REVISED OCTOBER 2003

'HC190 logic diagram

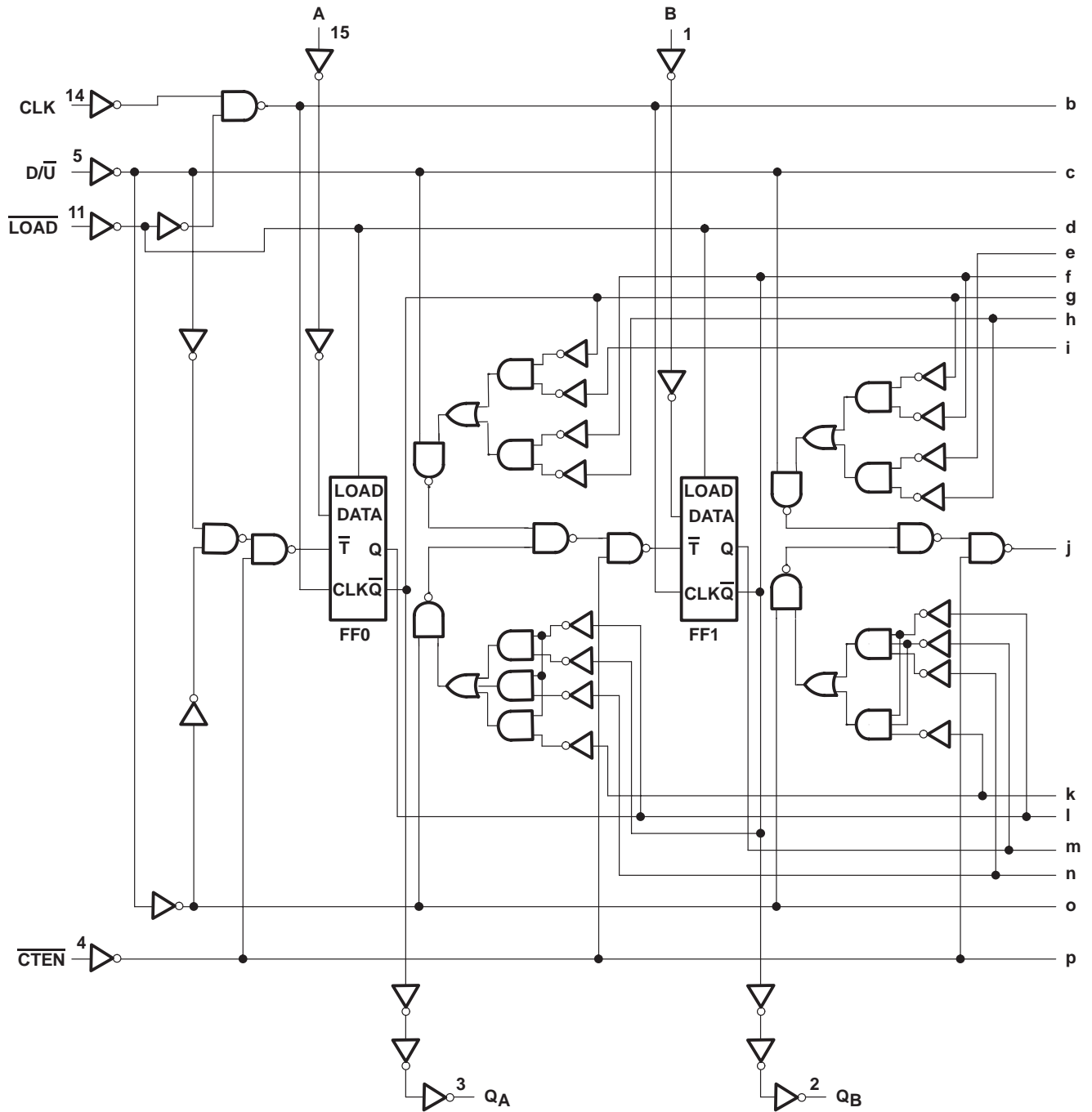

CD54HC190, CD74HC190
CD54HC191, CD74HC191, CD54HCT191, CD74HCT191
SYNCHRONOUS UP/DOWN COUNTERS WITH DOWN/UP MODE CONTROL

SCHS275E – MARCH 2002 – REVISED OCTOBER 2003

'HC190 logic diagram (continued)

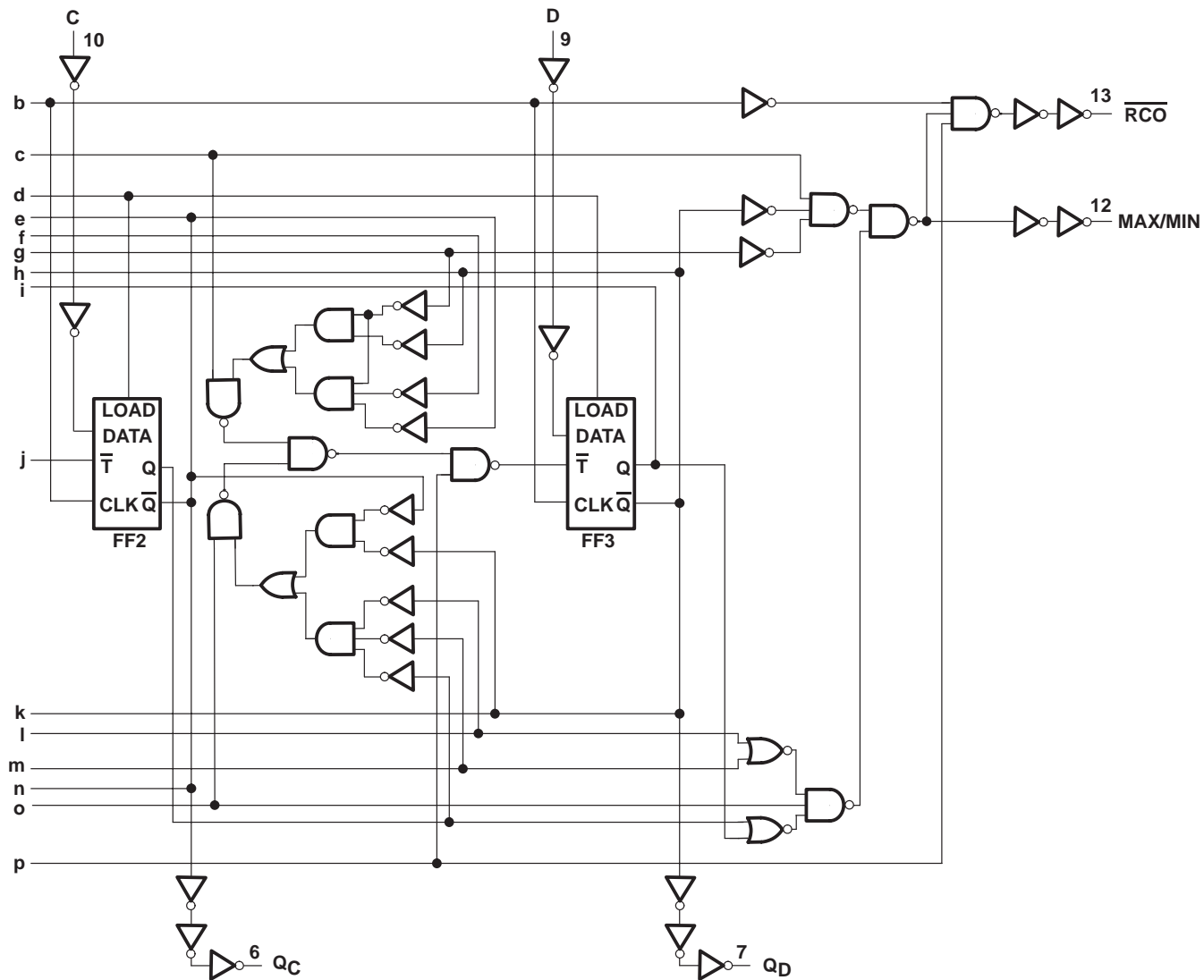

CD54HC190, CD74HC190
CD54HC191, CD74HC191, CD54HCT191, CD74HCT191
SYNCHRONOUS UP/DOWN COUNTERS WITH DOWN/UP MODE CONTROL

SCHS275E – MARCH 2002 – REVISED OCTOBER 2003

'HC191, 'HCT191 logic diagram

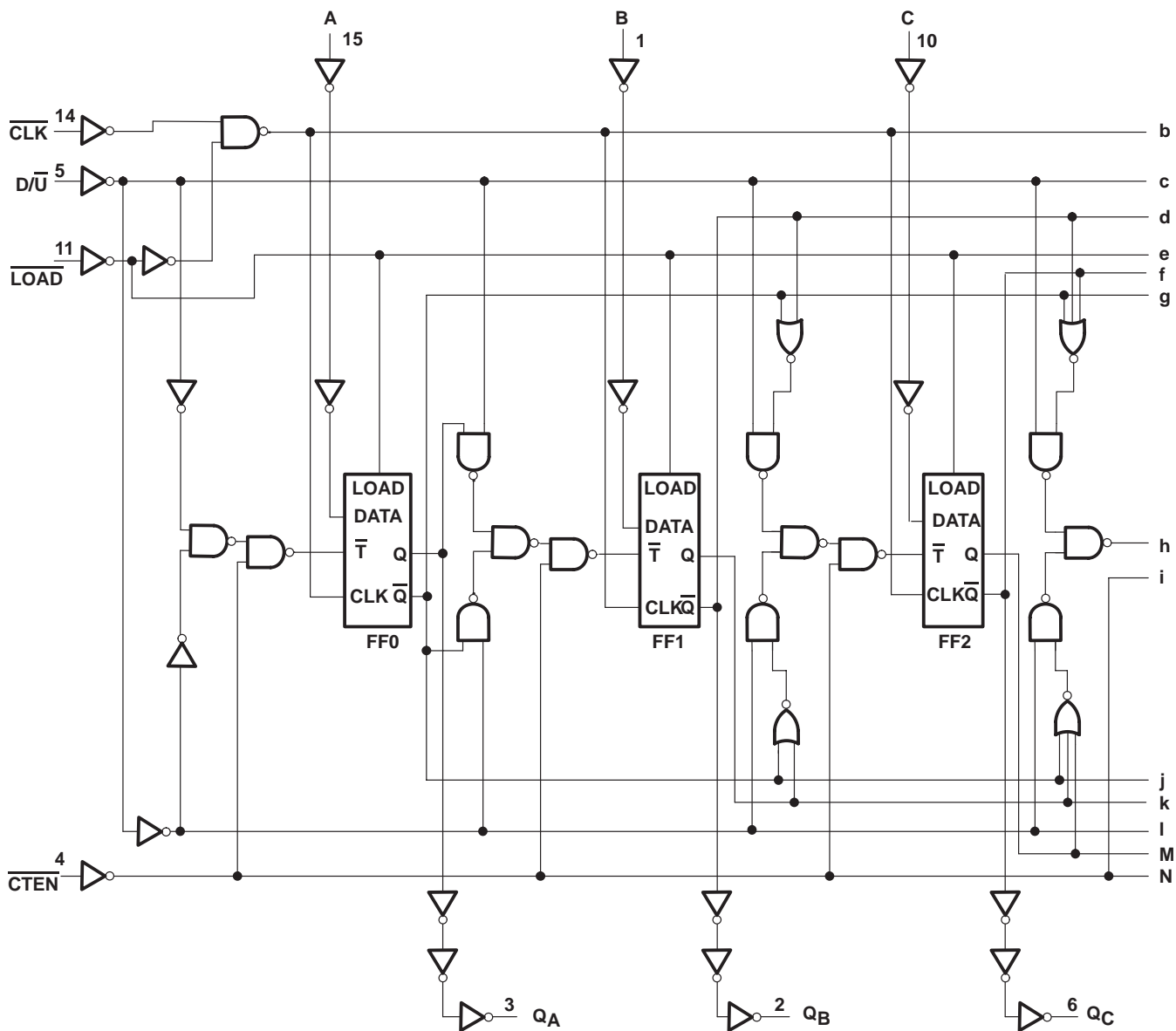

CD54HC190, CD74HC190
CD54HC191, CD74HC191, CD54HCT191, CD74HCT191
SYNCHRONOUS UP/DOWN COUNTERS WITH DOWN/UP MODE CONTROL

SCHS275E – MARCH 2002 – REVISED OCTOBER 2003

'HC190 and 'HC191/HCT191 flip-flop

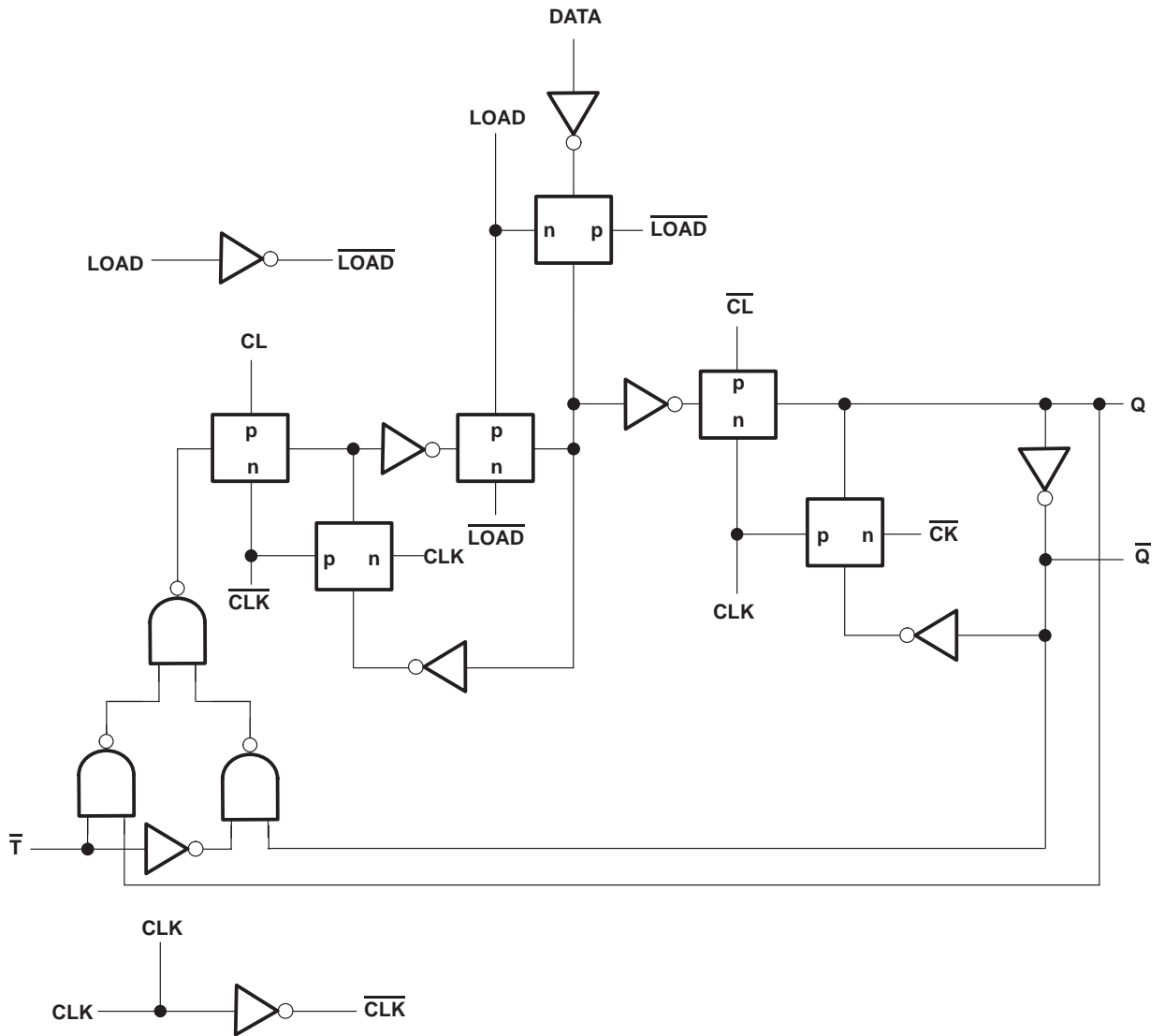

CD54HC190, CD74HC190
CD54HC191, CD74HC191, CD54HCT191, CD74HCT191
SYNCHRONOUS UP/DOWN COUNTERS WITH DOWN/UP MODE CONTROL

SCHS275E – MARCH 2002 – REVISED OCTOBER 2003

typical load, count, and inhibit sequence for 'HC190

The following sequence is illustrated below:

1. Load (preset) to BCD 7
2. Count up to 8, 9 (maximum), 0, 1, and 2
3. Inhibit
4. Count down to 1, 0 (minimum), 9, 8, and 7

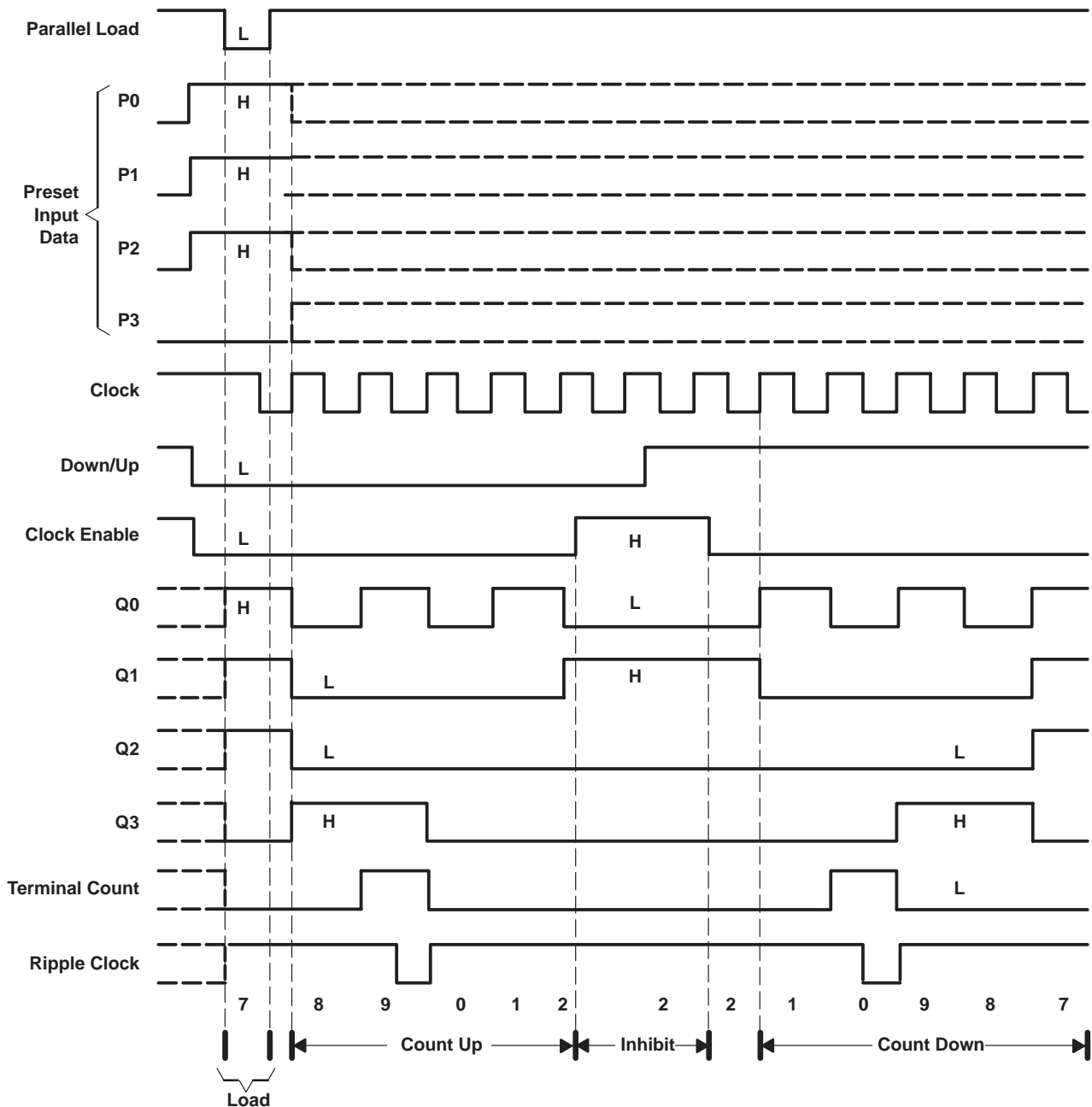

CD54HC190, CD74HC190
CD54HC191, CD74HC191, CD54HCT191, CD74HCT191
SYNCHRONOUS UP/DOWN COUNTERS WITH DOWN/UP MODE CONTROL

SCHS275E – MARCH 2002 – REVISED OCTOBER 2003

typical load, count, and inhibit sequence for 'HC191 and 'HCT191

The following sequence is illustrated below:

1. Load (preset) to binary 13
2. Count up to 14, 15 (maximum), 0, 1, and 2
3. Inhibit
4. Count down to 1, 0 (minimum), 15, 14, and 13

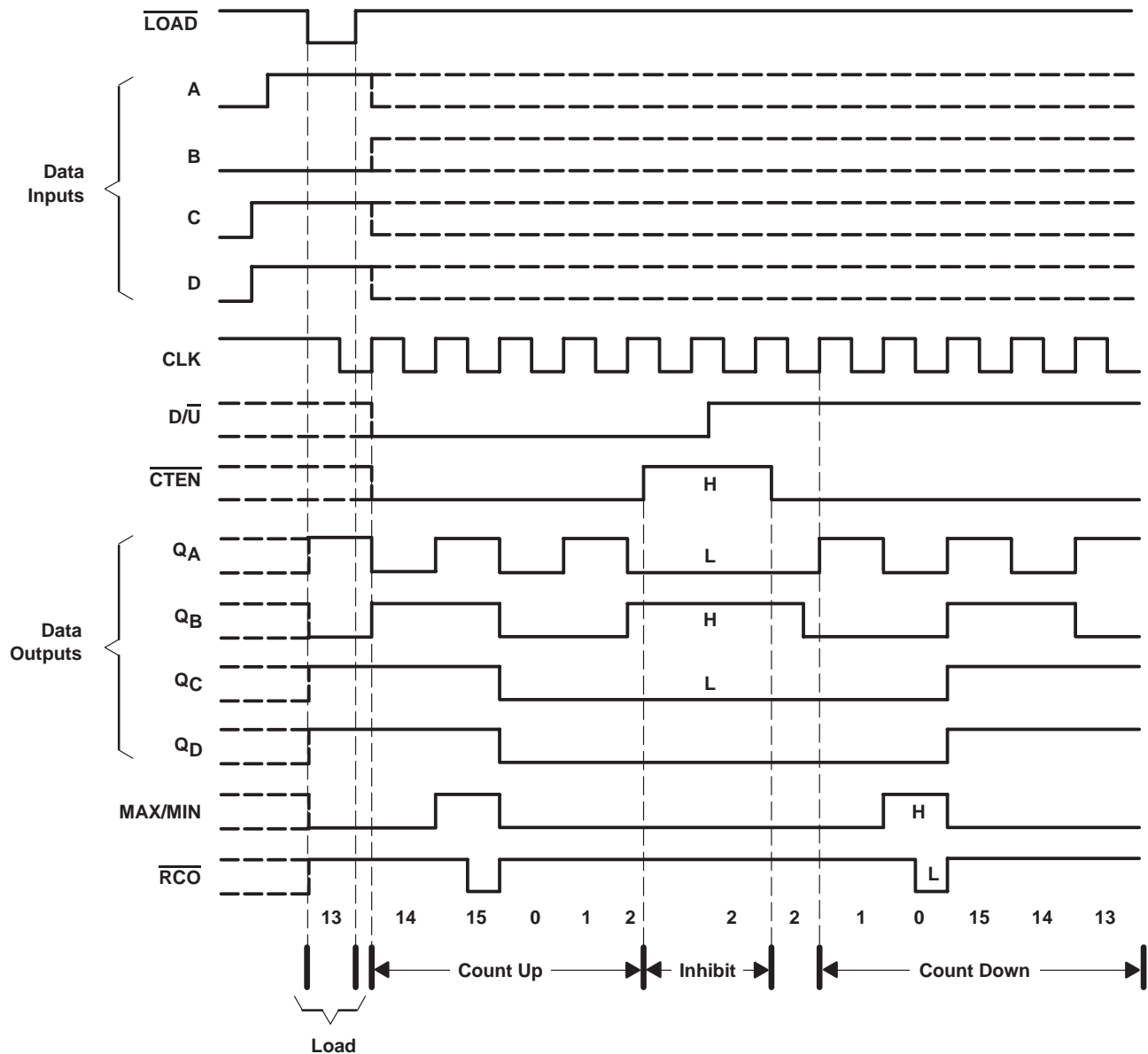

CD54HC190, CD74HC190
CD54HC191, CD74HC191, CD54HCT191, CD74HCT191
SYNCHRONOUS UP/DOWN COUNTERS WITH DOWN/UP MODE CONTROL

SCHS275E – MARCH 2002 – REVISED OCTOBER 2003

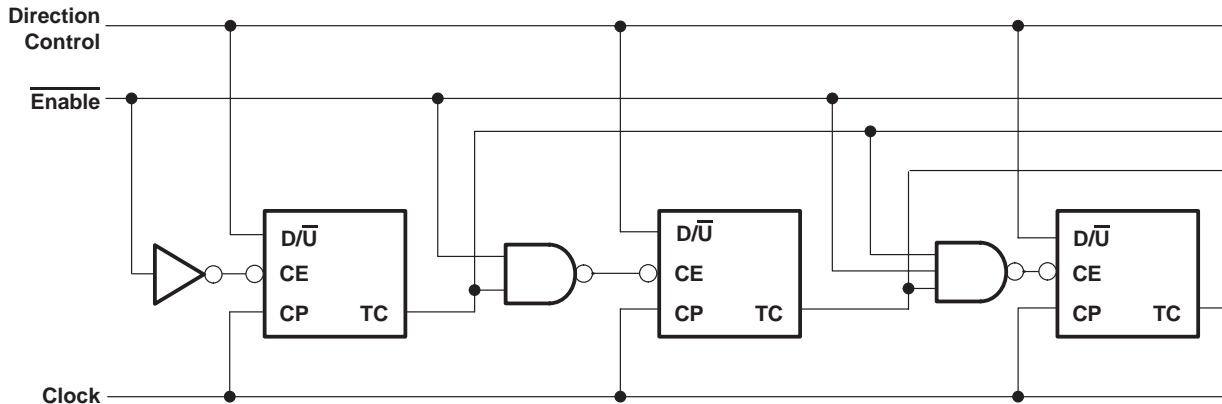

Figure 1. 'HC190 Synchronous n-Stage Counter With Parallel Gated Terminal Count

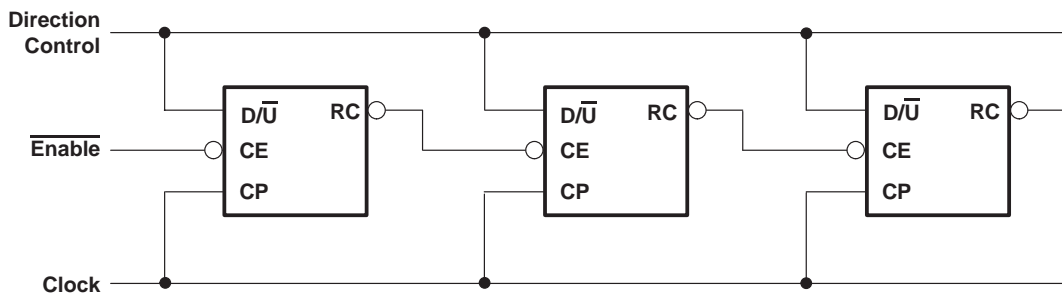
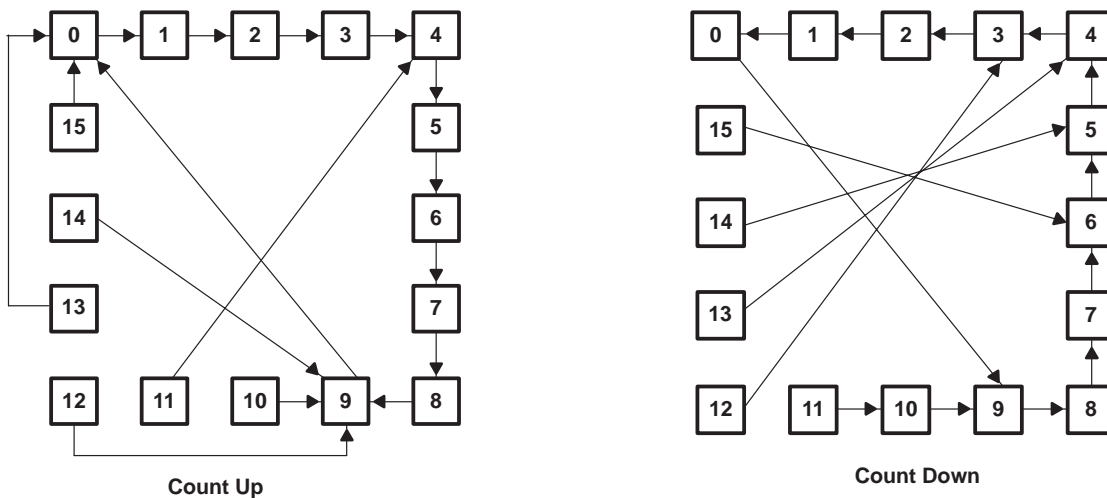

Figure 2. 'HC191, 'HCT191 Synchronous n-Stage Counter With Parallel Gated Terminal Count



NOTE: Illegal states in BCD counters corrected in one count

NOTE: Illegal states in BCD counters corrected in one or two counts

Figure 3. 'HC190 State Diagram

CD54HC190, CD74HC190
CD54HC191, CD74HC191, CD54HCT191, CD74HCT191
SYNCHRONOUS UP/DOWN COUNTERS WITH DOWN/UP MODE CONTROL

SCHS275E – MARCH 2002 – REVISED OCTOBER 2003

absolute maximum ratings over operating free-air temperature range (unless otherwise noted)†

Supply voltage range, V_{CC}	-0.5 V to 7 V
Input clamp current, I_{IK} ($V_I < 0$ or $V_I > V_{CC}$) (see Note 1)	± 20 mA
Output clamp current, I_{OK} ($V_O < 0$ or $V_O > V_{CC}$) (see Note 1)	± 20 mA
Continuous output drain current per output, I_O ($V_O = 0$ to V_{CC})	± 35 mA
Continuous output source or sink current per output, I_O ($V_O = 0$ to V_{CC})	± 25 mA
Continuous current through V_{CC} or GND	± 50 mA
Package thermal impedance, θ_{JA} (see Note 2): E package	67°C/W
M package	73°C/W
NS package	64°C/W
PW package	108°C/W
Storage temperature range, T_{stg}	-65°C to 150°C

† Stresses beyond those listed under “absolute maximum ratings” may cause permanent damage to the device. These are stress ratings only, and functional operation of the device at these or any other conditions beyond those indicated under “recommended operating conditions” is not implied. Exposure to absolute-maximum-rated conditions for extended periods may affect device reliability.

- NOTES: 1. The input and output voltage ratings may be exceeded if the input and output current ratings are observed.
 2. The package thermal impedance is calculated in accordance with JESD 51-7.

recommended operating conditions for 'HC190 and 'HC191 (see Note 3)

		$T_A = 25^\circ\text{C}$		$T_A = -55^\circ\text{C}$ TO 125°C		$T_A = -40^\circ\text{C}$ TO 85°C		UNIT
		MIN	MAX	MIN	MAX	MIN	MAX	
V_{CC}	Supply voltage	2	6	2	6	2	6	V
V_{IH}	High-level input voltage	$V_{CC} = 2\text{ V}$		1.5	1.5	1.5		V
		$V_{CC} = 4.5\text{ V}$		3.15	3.15	3.15		
		$V_{CC} = 6\text{ V}$		4.2	4.2	4.2		
V_{IL}	Low-level input voltage	$V_{CC} = 2\text{ V}$		0.5		0.5		V
		$V_{CC} = 4.5\text{ V}$		1.35		1.35		
		$V_{CC} = 6\text{ V}$		1.8		1.8		
V_I	Input voltage	0	V_{CC}	0	V_{CC}	0	V_{CC}	V
V_O	Output voltage	0	V_{CC}	0	V_{CC}	0	V_{CC}	V
t_t	Input transition (rise and fall) time	$V_{CC} = 2\text{ V}$		1000		1000		ns
		$V_{CC} = 4.5\text{ V}$		500		500		
		$V_{CC} = 6\text{ V}$		400		400		

NOTE 3: All unused inputs of the device must be held at V_{CC} or GND to ensure proper device operation. Refer to the TI application report, *Implications of Slow or Floating CMOS Inputs*, literature number SCBA004.

recommended operating conditions for 'HCT191 (see Note 4)

		$T_A = 25^\circ\text{C}$		$T_A = -55^\circ\text{C}$ TO 125°C		$T_A = -40^\circ\text{C}$ TO 85°C		UNIT
		MIN	MAX	MIN	MAX	MIN	MAX	
V_{CC}	Supply voltage	4.5	5.5	4.5	5.5	4.5	5.5	V
V_{IH}	High-level input voltage	2		2		2		V
V_{IL}	Low-level input voltage	0.8		0.8		0.8		V
V_I	Input voltage	V_{CC}		V_{CC}		V_{CC}		V
V_O	Output voltage	V_{CC}		V_{CC}		V_{CC}		V
t_t	Input transition (rise and fall) time	500		500		500		ns

NOTE 4: All unused inputs of the device must be held at V_{CC} or GND to ensure proper device operation. Refer to the TI application report, *Implications of Slow or Floating CMOS Inputs*, literature number SCBA004.



CD54HC190, CD74HC190
CD54HC191, CD74HC191, CD54HCT191, CD74HCT191
SYNCHRONOUS UP/DOWN COUNTERS WITH DOWN/UP MODE CONTROL

SCHS275E – MARCH 2002 – REVISED OCTOBER 2003

'HC190, 'HC191

electrical characteristics over recommended operating free-air temperature range (unless otherwise noted)

PARAMETER	TEST CONDITIONS		V _{CC}	T _A = 25°C		T _A = -55°C TO 125°C		T _A = -40°C TO 85°C		UNIT
				MIN	MAX	MIN	MAX	MIN	MAX	
V _{OH}	V _I = V _{IH} or V _{IL}	I _{OH} = -20 μA	2 V	1.9	1.9	1.9			V	
			4.5 V	4.4	4.4	4.4				
			6 V	5.9	5.9	5.9				
		I _{OH} = -4 mA	4.5 V	3.98	3.7	3.84				
		I _{OH} = -5.2 mA	6 V	5.48	5.2	5.34				
V _{OL}	V _I = V _{IH} or V _{IL}	I _{OL} = 20 μA	2 V	0.1	0.1	0.1		V		
			4.5 V	0.1	0.1	0.1				
			6 V	0.1	0.1	0.1				
		I _{OL} = 4 mA	4.5 V	0.26	0.4	0.33				
		I _{OL} = 5.2 mA	6 V	0.26	0.4	0.33				
I _I	V _I = V _{CC} or 0		6 V	±0.1		±1	±1	±1	μA	
I _{CC}	V _I = V _{CC} or 0, I _O = 0		6 V	8		160	80	80	μA	
C _i				10		10	10	10	pF	

'HCT191

electrical characteristics over recommended operating free-air temperature range (unless otherwise noted)

PARAMETER	TEST CONDITIONS		V _{CC}	T _A = 25°C			T _A = -55°C TO 125°C		T _A = -40°C TO 85°C		UNIT
				MIN	TYP	MAX	MIN	MAX	MIN	MAX	
V _{OH}	V _I = V _{IH} or V _{IL}	I _{OH} = -20 μA	4.5 V	4.4			4.4		4.4	V	
		I _{OH} = -4 mA		3.98			3.7		3.84		
V _{OL}	V _I = V _{IH} or V _{IL}	I _{OL} = 20 μA	4.5 V				0.1		0.1	V	
		I _{OL} = 4 mA					0.26		0.4		0.33
I _I	V _I = V _{CC} to GND		5.5 V				±0.1		±1	±1	μA
I _{CC}	V _I = V _{CC} or 0, I _O = 0		5.5 V				8		160	80	μA
ΔI _{CC} †	One input at V _{CC} - 2.1 V, Other inputs at 0 or V _{CC}		4.5 V to 5.5 V		100	360			490	450	μA
C _i							10		10	10	pF

† Additional quiescent supply current per input pin, TTL inputs high, 1 unit load

HCT INPUT LOADING TABLE

INPUTS	UNIT LOADS
A-D	0.4
CLK	1.5
LOAD	1.5
D/Ū	1.2
CTEN	1.5

Unit load is ΔI_{CC} limit specified in electrical characteristics table, (e.g., 360 μA max at 25°C).



CD54HC190, CD74HC190
CD54HC191, CD74HC191, CD54HCT191, CD74HCT191
SYNCHRONOUS UP/DOWN COUNTERS WITH DOWN/UP MODE CONTROL

SCHS275E – MARCH 2002 – REVISED OCTOBER 2003

'HC190, 'HC191 timing requirements over recommended operating free-air temperature range (unless otherwise noted) (see Figure 4)

		V _{CC}	T _A = 25°C		T _A = -55°C TO 125°C		T _A = -40°C TO 85°C		UNIT
			MIN	MAX	MIN	MAX	MIN	MAX	
f _{clock}	Clock frequency†	2 V	6		4		5		MHz
		4.5 V	30		20		25		
		6 V	35		23		29		
t _w	$\overline{\text{LOAD}}$ low	2 V	80		120		100		ns
		4.5 V	16		24		20		
		6 V	14		20		17		
	CLK high or low	2 V	100		150		125		
		4.5 V	20		30		25		
		6 V	17		26		21		
t _{su}	Data before $\overline{\text{LOAD}}\uparrow$	2 V	60		90		75		ns
		4.5 V	12		18		15		
		6 V	10		15		13		
	$\overline{\text{CTEN}}$ before CLK \uparrow	2 V	60		90		75		
		4.5 V	12		18		15		
		6 V	10		15		13		
	D/ $\overline{\text{U}}$ before CLK \uparrow	2 V	90		135		115		
		4.5 V	18		27		23		
		6 V	15		23		20		
t _h	Data before $\overline{\text{LOAD}}\uparrow$	2 V	2		2		2		ns
		4.5 V	2		2		2		
		6 V	2		2		2		
	$\overline{\text{CTEN}}$ before CLK \uparrow	2 V	2		2		2		
		4.5 V	2		2		2		
		6 V	2		2		2		
	D/ $\overline{\text{U}}$ before CLK \uparrow	2 V	0		0		0		
		4.5 V	0		0		0		
		6 V	0		0		0		
t _{rec}	$\overline{\text{LOAD}}$ inactive before CLK \uparrow	2 V	60		90		75		ns
		4.5 V	12		18		15		
		6 V	10		15		13		

† Applies to noncascaded operation only. With cascaded counters, clock-to-terminal count propagation delays, CTEN-to-clock setup times, and CTEN-to-clock hold times determine maximum clock frequency. For example, with these HC devices:

$$f_{\text{max}}(\text{CLK}) = \frac{1}{\text{CLK-to-MAX/MIN propagation delay} + \overline{\text{CTEN-to-CLK}} \text{ setup time} + \overline{\text{CTEN-to-CLK}} \text{ hold time}} = \frac{1}{42 + 12 + 2} \approx 18 \text{ MHz}$$



CD54HC190, CD74HC190
CD54HC191, CD74HC191, CD54HCT191, CD74HCT191
SYNCHRONOUS UP/DOWN COUNTERS WITH DOWN/UP MODE CONTROL

SCHS275E – MARCH 2002 – REVISED OCTOBER 2003

'HC190, 'HC191

switching characteristics over recommended operating free-air temperature range (unless otherwise noted) (see Figure 4)

PARAMETER	FROM (INPUT)	TO (OUTPUT)	LOAD CAPACITANCE	V _{CC}	T _A = 25°C			T _A = -55°C TO 125°C		T _A = -40°C TO 85°C		UNIT
					MIN	TYP	MAX	MIN	MAX	MIN	MAX	
f _{max}				2 V	6			4		5	MHz	
				4.5 V	30			20		25		
				6 V	35			23		29		
t _{pd}	$\overline{\text{LOAD}}$	Q	C _L = 50 pF	2 V		195		295		245	ns	
				4.5 V		39		59		49		
				6 V		33		50		42		
	A, B, C, or D	Q	C _L = 50 pF	2 V		175		265		220		
				4.5 V		35		53		44		
				6 V		30		45		37		
	CLK	Q	C _L = 50 pF	2 V		170		255		215		
				4.5 V		34		51		43		
				6 V		29		43		37		
	CLK	$\overline{\text{RCO}}$	C _L = 50 pF	2 V		125		190		155		
				4.5 V		25		38		31		
				6 V		21		32		26		
	CLK	MAX/MIN	C _L = 50 pF	2 V		210		315		265		
				4.5 V		42		63		53		
				6 V		36		54		45		
	D/ $\overline{\text{U}}$	$\overline{\text{RCO}}$	C _L = 50 pF	2 V		150		225		190		
				4.5 V		30		45		38		
				6 V		26		38		33		
	D/ $\overline{\text{U}}$	MAX/MIN	C _L = 50 pF	2 V		165		250		205		
				4.5 V		33		50		41		
				6 V		28		43		35		
	$\overline{\text{CTEN}}$	$\overline{\text{RCO}}$	C _L = 50 pF	2 V		125		190		155		
				4.5 V		25		38		31		
				6 V		21		32		26		
	C _L = 15 pF	5 V	10									
	t _t	Any	C _L = 50 pF	2 V		75		110		95		ns
				4.5 V		15		22		19		
				6 V		13		19		16		



CD54HC190, CD74HC190
CD54HC191, CD74HC191, CD54HCT191, CD74HCT191
SYNCHRONOUS UP/DOWN COUNTERS WITH DOWN/UP MODE CONTROL

SCHS275E – MARCH 2002 – REVISED OCTOBER 2003

'HCT191

timing requirements over recommended operating free-air temperature range $V_{CC} = 4.5\text{ V}$ (unless otherwise noted) (see Figure 5)

		$T_A = 25^\circ\text{C}$		$T_A = -55^\circ\text{C}$ TO 125°C		$T_A = -40^\circ\text{C}$ TO 85°C		UNIT
		MIN	MAX	MIN	MAX	MIN	MAX	
f_{clock}	Clock frequency	30		20		25		MHz
t_w	Pulse duration	$\overline{\text{LOAD}}$ low	16	24	20			ns
		CLK high or low	20	30	25			
t_{su}	Setup time	Data before $\overline{\text{LOAD}}\uparrow$	12	18	15			ns
		$\overline{\text{CTEN}}$ before $\text{CLK}\uparrow$	12	18	15			
		$\text{D}/\overline{\text{U}}$ before $\text{CLK}\uparrow$	18	27	23			
t_h	Hold time	Data before $\overline{\text{LOAD}}\uparrow$	2	2	2			ns
		$\overline{\text{CTEN}}$ before $\text{CLK}\uparrow$	2	2	2			
		$\text{D}/\overline{\text{U}}$ before $\text{CLK}\uparrow$	0	0	0			
t_{rec}	Recovery time	$\overline{\text{LOAD}}$ inactive before $\text{CLK}\uparrow$	12	18	15			ns

'HCT191

switching characteristics over recommended operating free-air temperature range (unless otherwise noted) (see Figure 5)

PARAMETER	FROM (INPUT)	TO (OUTPUT)	LOAD CAPACITANCE	V_{CC}	$T_A = 25^\circ\text{C}$			$T_A = -55^\circ\text{C}$ TO 125°C		$T_A = -40^\circ\text{C}$ TO 85°C		UNIT
					MIN	TYP	MAX	MIN	MAX	MIN	MAX	
f_{max}				4.5 V	30			20		25		MHz
t_{pd}	$\overline{\text{LOAD}}$	Q	$C_L = 50\text{ pF}$	4.5 V			40		60		50	ns
			$C_L = 15\text{ pF}$	5 V		17						
	A, B, C, or D	Q	$C_L = 50\text{ pF}$	4.5 V			38		57		48	
			$C_L = 15\text{ pF}$	5 V		16						
	CLK	$\overline{\text{RCO}}$	$C_L = 50\text{ pF}$	4.5 V			35		53		44	
			$C_L = 15\text{ pF}$	5 V		14						
	CLK	Q	$C_L = 50\text{ pF}$	4.5 V			27		41		34	
			$C_L = 15\text{ pF}$	5 V		11						
	CLK	MAX/MIN	$C_L = 50\text{ pF}$	4.5 V			42		63		53	
			$C_L = 15\text{ pF}$	5 V		18						
	$\text{D}/\overline{\text{U}}$	$\overline{\text{RCO}}$	$C_L = 50\text{ pF}$	4.5 V			30		45		38	
			$C_L = 15\text{ pF}$	5 V		12						
	$\text{D}/\overline{\text{U}}$	MAX/MIN	$C_L = 50\text{ pF}$	4.5 V			38		57		48	
			$C_L = 15\text{ pF}$	5 V		16						
$\overline{\text{CTEN}}$	$\overline{\text{RCO}}$	$C_L = 50\text{ pF}$	4.5 V			27		41		34		
		$C_L = 15\text{ pF}$	5 V		11							
t_t		Any	$C_L = 50\text{ pF}$	4.5 V			15		22		19	ns



CD54HC190, CD74HC190
CD54HC191, CD74HC191, CD54HCT191, CD74HCT191
SYNCHRONOUS UP/DOWN COUNTERS WITH DOWN/UP MODE CONTROL

SCHS275E – MARCH 2002 – REVISED OCTOBER 2003

operating characteristics, $V_{CC} = 5\text{ V}$, $T_A = 25^\circ\text{C}$

PARAMETER		TYP	UNIT
C_{pd} Power dissipation capacitance	'HC190	59	pF
	'HC191	55	
	'HCT191	68	

CD54HC190, CD74HC190
CD54HC191, CD74HC191, CD54HCT191, CD74HCT191
SYNCHRONOUS UP/DOWN COUNTERS WITH DOWN/UP MODE CONTROL

SCHS275E – MARCH 2002 – REVISED OCTOBER 2003

PARAMETER MEASUREMENT INFORMATION – 'HC190, 'HC191

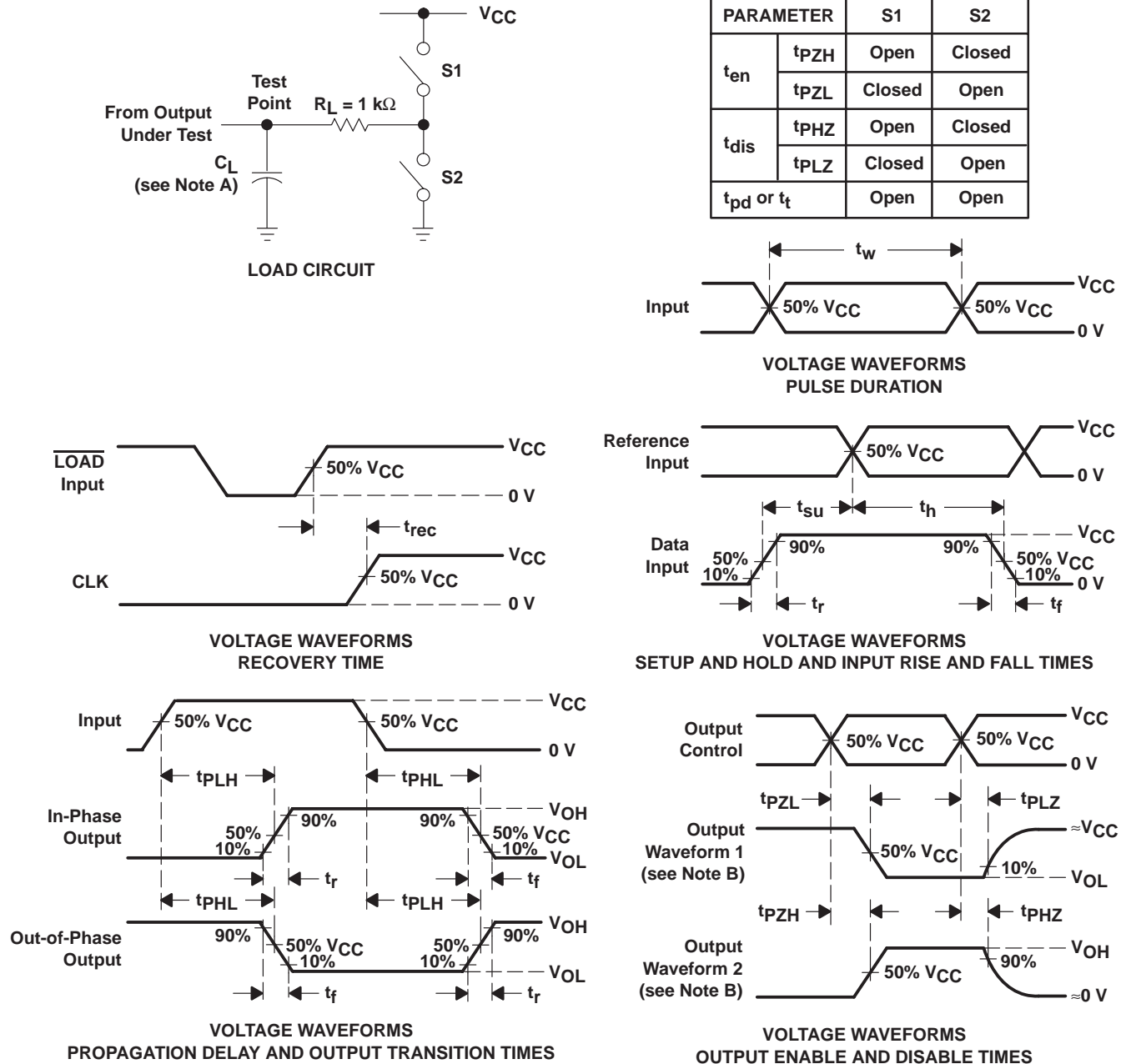

- NOTES: A. C_L includes probe and test-fixture capacitance.
 B. Waveform 1 is for an output with internal conditions such that the output is low except when disabled by the output control. Waveform 2 is for an output with internal conditions such that the output is high except when disabled by the output control.
 C. Phase relationships between waveforms were chosen arbitrarily. All input pulses are supplied by generators having the following characteristics: $PRR \leq 1\text{ MHz}$, $Z_O = 50\ \Omega$, $t_r = 6\text{ ns}$, $t_f = 6\text{ ns}$.
 D. For clock inputs, f_{max} is measured with the input duty cycle at 50%.
 E. The outputs are measured one at a time with one input transition per measurement.
 F. t_{PLZ} and t_{PHZ} are the same as t_{dis} .
 G. t_{PZL} and t_{PZH} are the same as t_{en} .
 H. t_{PLH} and t_{PHL} are the same as t_{pd} .

Figure 4. Load Circuit and Voltage Waveforms

CD54HC190, CD74HC190
CD54HC191, CD74HC191, CD54HCT191, CD74HCT191
SYNCHRONOUS UP/DOWN COUNTERS WITH DOWN/UP MODE CONTROL

SCHS275E – MARCH 2002 – REVISED OCTOBER 2003

PARAMETER MEASUREMENT INFORMATION – 'HCT191

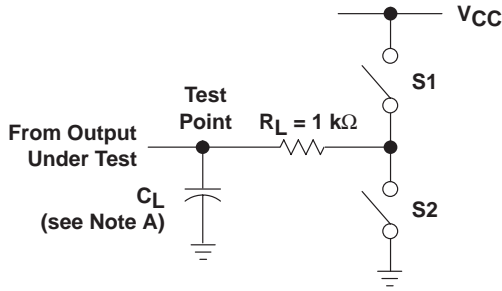

LOAD CIRCUIT

PARAMETER	S1	S2	
t_{en}	t_{PZH}	Open	Closed
	t_{PZL}	Closed	Open
t_{dis}	t_{PHZ}	Open	Closed
	t_{PLZ}	Closed	Open
t_{pd} or t_t	Open	Open	

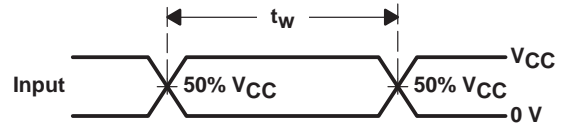

VOLTAGE WAVEFORMS PULSE DURATION

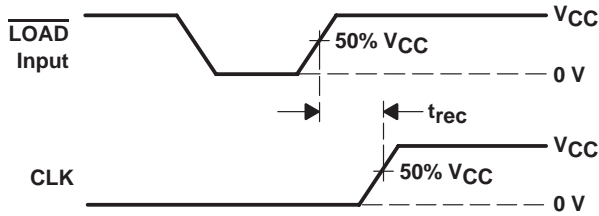

VOLTAGE WAVEFORMS RECOVERY TIME

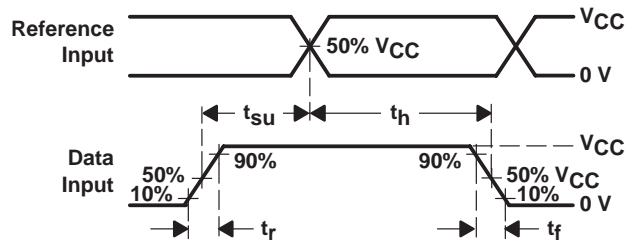

VOLTAGE WAVEFORMS SETUP AND HOLD AND INPUT RISE AND FALL TIMES

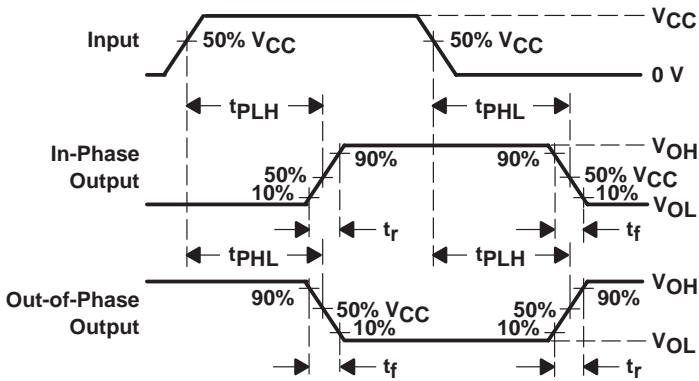

VOLTAGE WAVEFORMS PROPAGATION DELAY AND OUTPUT TRANSITION TIMES

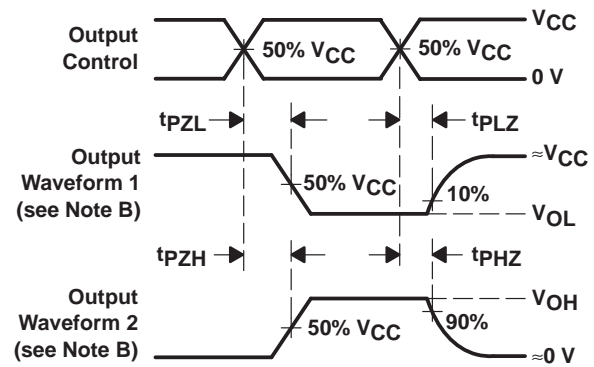

VOLTAGE WAVEFORMS OUTPUT ENABLE AND DISABLE TIMES

- NOTES: A. C_L includes probe and test-fixture capacitance.
 B. Waveform 1 is for an output with internal conditions such that the output is low except when disabled by the output control. Waveform 2 is for an output with internal conditions such that the output is high except when disabled by the output control.
 C. Phase relationships between waveforms were chosen arbitrarily. All input pulses are supplied by generators having the following characteristics: $PRR \leq 1$ MHz, $Z_O = 50 \Omega$, $t_r = 6$ ns, $t_f = 6$ ns.
 D. For clock inputs, f_{max} is measured with the input duty cycle at 50%.
 E. The outputs are measured one at a time with one input transition per measurement.
 F. t_{PLZ} and t_{PHZ} are the same as t_{dis} .
 G. t_{PZL} and t_{PZH} are the same as t_{en} .
 H. t_{PLH} and t_{PHL} are the same as t_{pd} .

Figure 5. Load Circuit and Voltage Waveforms



J (R-GDIP-T**)

14 LEADS SHOWN

CERAMIC DUAL IN-LINE PACKAGE



DIM \ PINS **	14	16	18	20
A	0.300 (7,62) BSC	0.300 (7,62) BSC	0.300 (7,62) BSC	0.300 (7,62) BSC
B MAX	0.785 (19,94)	.840 (21,34)	0.960 (24,38)	1.060 (26,92)
B MIN	—	—	—	—
C MAX	0.300 (7,62)	0.300 (7,62)	0.310 (7,87)	0.300 (7,62)
C MIN	0.245 (6,22)	0.245 (6,22)	0.220 (5,59)	0.245 (6,22)



4040083/F 03/03

- NOTES:
- A. All linear dimensions are in inches (millimeters).
 - B. This drawing is subject to change without notice.
 - C. This package is hermetically sealed with a ceramic lid using glass frit.
 - D. Index point is provided on cap for terminal identification only on press ceramic glass frit seal only.
 - E. Falls within MIL STD 1835 GDIP1-T14, GDIP1-T16, GDIP1-T18 and GDIP1-T20.

N (R-PDIP-T**)

PLASTIC DUAL-IN-LINE PACKAGE

16 PINS SHOWN



- NOTES:
- A. All linear dimensions are in inches (millimeters).
 - B. This drawing is subject to change without notice.
 - Falls within JEDEC MS-001, except 18 and 20 pin minimum body length (Dim A).
 - The 20 pin end lead shoulder width is a vendor option, either half or full width.

D (R-PDSO-G16)

PLASTIC SMALL-OUTLINE PACKAGE

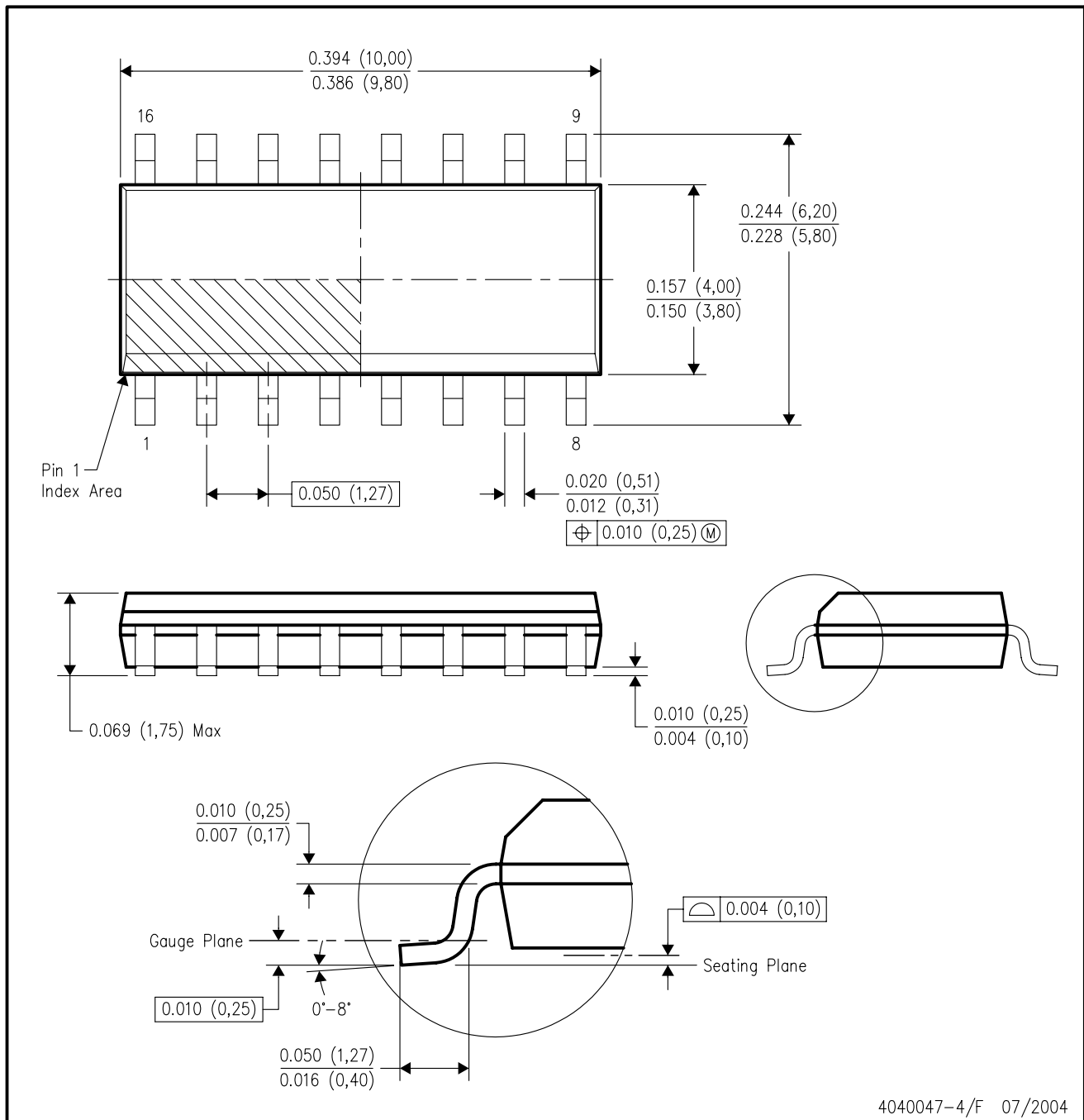

- NOTES:
- A. All linear dimensions are in inches (millimeters).
 - B. This drawing is subject to change without notice.
 - C. Body dimensions do not include mold flash or protrusion not to exceed 0.006 (0,15).
 - D. Falls within JEDEC MS-012 variation AC.

MECHANICAL DATA

NS (R-PDSO-G)**

PLASTIC SMALL-OUTLINE PACKAGE

14-PINS SHOWN



- NOTES:
- A. All linear dimensions are in millimeters.
 - B. This drawing is subject to change without notice.
 - C. Body dimensions do not include mold flash or protrusion, not to exceed 0,15.

PW (R-PDSO-G**)

PLASTIC SMALL-OUTLINE PACKAGE

14 PINS SHOWN



4040064/F 01/97

- NOTES: A. All linear dimensions are in millimeters.
 B. This drawing is subject to change without notice.
 C. Body dimensions do not include mold flash or protrusion not to exceed 0,15.
 D. Falls within JEDEC MO-153

IMPORTANT NOTICE

Texas Instruments Incorporated and its subsidiaries (TI) reserve the right to make corrections, modifications, enhancements, improvements, and other changes to its products and services at any time and to discontinue any product or service without notice. Customers should obtain the latest relevant information before placing orders and should verify that such information is current and complete. All products are sold subject to TI's terms and conditions of sale supplied at the time of order acknowledgment.

TI warrants performance of its hardware products to the specifications applicable at the time of sale in accordance with TI's standard warranty. Testing and other quality control techniques are used to the extent TI deems necessary to support this warranty. Except where mandated by government requirements, testing of all parameters of each product is not necessarily performed.

TI assumes no liability for applications assistance or customer product design. Customers are responsible for their products and applications using TI components. To minimize the risks associated with customer products and applications, customers should provide adequate design and operating safeguards.

TI does not warrant or represent that any license, either express or implied, is granted under any TI patent right, copyright, mask work right, or other TI intellectual property right relating to any combination, machine, or process in which TI products or services are used. Information published by TI regarding third-party products or services does not constitute a license from TI to use such products or services or a warranty or endorsement thereof. Use of such information may require a license from a third party under the patents or other intellectual property of the third party, or a license from TI under the patents or other intellectual property of TI.

Reproduction of information in TI data books or data sheets is permissible only if reproduction is without alteration and is accompanied by all associated warranties, conditions, limitations, and notices. Reproduction of this information with alteration is an unfair and deceptive business practice. TI is not responsible or liable for such altered documentation.

Resale of TI products or services with statements different from or beyond the parameters stated by TI for that product or service voids all express and any implied warranties for the associated TI product or service and is an unfair and deceptive business practice. TI is not responsible or liable for any such statements.

Following are URLs where you can obtain information on other Texas Instruments products and application solutions:

Products		Applications	
Amplifiers	amplifier.ti.com	Audio	www.ti.com/audio
Data Converters	dataconverter.ti.com	Automotive	www.ti.com/automotive
DSP	dsp.ti.com	Broadband	www.ti.com/broadband
Interface	interface.ti.com	Digital Control	www.ti.com/digitalcontrol
Logic	logic.ti.com	Military	www.ti.com/military
Power Mgmt	power.ti.com	Optical Networking	www.ti.com/opticalnetwork
Microcontrollers	microcontroller.ti.com	Security	www.ti.com/security
		Telephony	www.ti.com/telephony
		Video & Imaging	www.ti.com/video
		Wireless	www.ti.com/wireless

Mailing Address: Texas Instruments
Post Office Box 655303 Dallas, Texas 75265