

## OVERVOLTAGE AND OVERCURRENT PROTECTION IC AND Li+ CHARGER FRONT-END PROTECTION IC

### FEATURES

- Provides Protection for Three Variables:
  - Input Overvoltage, with Rapid Response in < 1  $\mu$ s
  - User-Programmable Overcurrent with Current Limiting
  - Battery Overvoltage
- 30V Maximum Input Voltage
- Supports up to 1.5A Input Current
- Robust Against False Triggering Due to Current Transients
- Thermal Shutdown
- Enable Input
- Status Indication – Fault Condition

- Available in Space-Saving Small 8 Lead 2x2 SON and 12 Lead 4x3 SON Packages

### APPLICATIONS

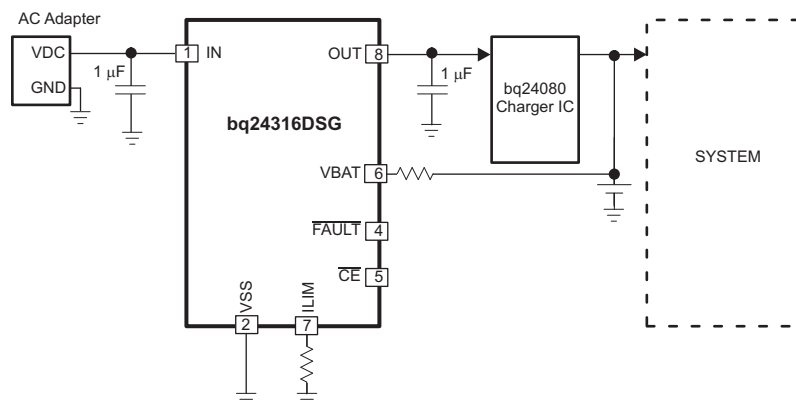
- Mobile Phones and Smart Phones
- PDAs
- MP3 Players
- Low-Power Handheld Devices
- Bluetooth Headsets

### DESCRIPTION

The bq24314 and bq24316 are highly integrated circuits designed to provide protection to Li-ion batteries from failures of the charging circuit. The IC continuously monitors the input voltage, the input current, and the battery voltage. In case of an input overvoltage condition, the IC immediately removes power from the charging circuit by turning off an internal switch. In the case of an overcurrent condition, it limits the system current at the threshold value, and if the overcurrent persists, switches the pass element OFF after a blanking period. Additionally, the IC also monitors its own die temperature and switches off if it becomes too hot. The input overcurrent threshold is user-programmable.

The IC can be controlled by a processor and also provides status information about fault conditions to the host.

### APPLICATION SCHEMATIC



Please be aware that an important notice concerning availability, standard warranty, and use in critical applications of Texas Instruments semiconductor products and disclaimers thereto appears at the end of this data sheet.

PowerPAD is a trademark of Texas Instruments.



These devices have limited built-in ESD protection. The leads should be shorted together or the device placed in conductive foam during storage or handling to prevent electrostatic damage to the MOS gates.

### ORDERING INFORMATION<sup>(1)</sup>

DEVICE <sup>(2)</sup>	OVP THRESHOLD	PACKAGE	MARKING
bq24314DSG	5.85 V	2mm x 2mm SON	CBV
bq24314DSJ	5.85 V	4mm x 3mm SON	CBX
bq24316DSG	6.80 V	2mm x 2mm SON	CBW
bq24316DSJ	6.80 V	4mm x 3mm SON	BZC

- (1) For the most current package and ordering information, see the Package Option Addendum at the end of this document, or see the TI website at [www.ti.com](http://www.ti.com).
- (2) To order a 3000 pcs reel add R to the part number, or to order a 250 pcs reel add T to the part number.

### PACKAGE DISSIPATION RATINGS

PART NO.	PACKAGE	R <sub>θJC</sub>	R <sub>θJA</sub>
BQ24314DSG BQ24316DSG	2x2 SON	5°C/W	75°C/W
BQ24314DSJ BQ24316DSJ	4x3 SON	5°C/W	40°C/W

### ABSOLUTE MAXIMUM RATINGS<sup>(1)</sup>

over operating free-air temperature range (unless otherwise noted)

PARAMETER	PIN	VALUE	UNIT
Input voltage	IN (with respect to VSS)	–0.3 to 30	V
	OUT (with respect to VSS)	–0.3 to 12	
	ILIM, FAULT, CE, VBAT (with respect to VSS)	–0.3 to 7	
Input current	IN	2.0	A
Output current	OUT	2.0	A
Output sink current	FAULT	15	mA
Junction temperature, T <sub>J</sub>		–40 to 150	°C
Storage temperature, T <sub>STG</sub>		–65 to 150	°C
Lead temperature (soldering, 10 seconds)		300	°C

- (1) Stresses beyond those listed under absolute maximum ratings may cause permanent damage to the device. These are stress ratings only, and functional operation of the device at these or any other conditions beyond those indicated under recommended operating conditions is not implied. Exposure to absolute-maximum-rated conditions for extended periods may affect device reliability. All voltage values are with respect to the network ground terminal unless otherwise noted.

### RECOMMENDED OPERATING CONDITIONS

over operating free-air temperature range (unless otherwise noted)

		MIN	MAX	UNIT
V <sub>IN</sub>	Input voltage range	3.3	26	V
I <sub>IN</sub>	Input current, IN pin		1.5	A
I <sub>OUT</sub>	Output current, OUT pin		1.5	A
R <sub>ILIM</sub>	OCP Programming resistor	15.0	90.0	kΩ
T <sub>J</sub>	Junction temperature	0	125	°C

## ELECTRICAL CHARACTERISTICS

over junction temperature range  $0^{\circ}\text{C} \leq T_J \leq 125^{\circ}\text{C}$  and recommended supply voltage (unless otherwise noted)

PARAMETER		TEST CONDITIONS	MIN	TYP	MAX	UNIT	
<b>IN</b>							
$V_{UVLO}$	Under-voltage lock-out, input power detected threshold	$\overline{CE} = \text{Low}$ , $V_{IN}$ increasing from 0V to 3V	2.6	2.7	2.8	V	
$V_{HYS-UVLO}$	Hysteresis on UVLO	$\overline{CE} = \text{Low}$ , $V_{IN}$ decreasing from 3V to 0V	200	260	300	mV	
$T_{DGL(PGOOD)}$	Deglitch time, input power detected status	$\overline{CE} = \text{Low}$ . Time measured from $V_{IN}$ 0V $\rightarrow$ 5V 1 $\mu$ s rise-time, to output turning ON		8		ms	
$I_{DD}$	Operating current	$\overline{CE} = \text{Low}$ , No load on OUT pin, $V_{IN} = 5\text{V}$ , $R_{ILIM} = 25\text{k}\Omega$		400	600	$\mu$ A	
$I_{STDBY}$	Standby current	$\overline{CE} = \text{High}$ , $V_{IN} = 5.0\text{V}$		65	95	$\mu$ A	
<b>INPUT TO OUTPUT CHARACTERISTICS</b>							
$V_{DO}$	Drop-out voltage IN to OUT	$\overline{CE} = \text{Low}$ , $V_{IN} = 5\text{V}$ , $I_{OUT} = 1\text{A}$		170	280	mV	
<b>INPUT OVERVOLTAGE PROTECTION</b>							
$V_{OVP}$	Input overvoltage protection threshold	bq24314	$\overline{CE} = \text{Low}$ , $V_{IN}$ increasing from 5V to 7.5V	5.71	5.85	6.00	V
		bq24316		6.60	6.80	7.00	V
$t_{PD(OVP)}$	Input OV propagation delay <sup>(1)</sup>	$\overline{CE} = \text{Low}$			1	$\mu$ s	
$V_{HYS-OVP}$	Hysteresis on OVP	$\overline{CE} = \text{Low}$ , $V_{IN}$ decreasing from 7.5V to 5V	25	60	110	mV	
$t_{ON(OVP)}$	Recovery time from input overvoltage condition	$\overline{CE} = \text{Low}$ , Time measured from $V_{IN}$ 7.5V $\rightarrow$ 5V, 1 $\mu$ s fall-time		8		ms	
<b>INPUT OVERCURRENT PROTECTION</b>							
$I_{OCP}$	Input overcurrent protection threshold range		300		1500	mA	
$I_{OCP}$	Input overcurrent protection threshold	$\overline{CE} = \text{Low}$ , $R_{ILIM} = 25\text{k}\Omega$	930	1000	1070	mA	
$t_{BLANK(OCP)}$	Blanking time, input overcurrent detected			176		$\mu$ s	
$t_{REC(OCP)}$	Recovery time from input overcurrent condition			64		ms	
<b>BATTERY OVERVOLTAGE PROTECTION</b>							
$BV_{OVP}$	Battery overvoltage protection threshold	$\overline{CE} = \text{Low}$ , $V_{IN} > 4.4\text{V}$	4.30	4.35	4.4	V	
$V_{HYS-BOVP}$	Hysteresis on $BV_{OVP}$	$\overline{CE} = \text{Low}$ , $V_{IN} > 4.4\text{V}$	200	275	320	mV	
$I_{VBAT}$	Input bias current on VBAT pin	DSG Package	$V_{BAT} = 4.4\text{V}$ , $T_J = 25^{\circ}\text{C}$		10	nA	
		DSJ Package	$V_{BAT} = 4.4\text{V}$ , $T_J = 85^{\circ}\text{C}$		10		
$T_{DGL(BOVP)}$	Deglitch time, battery overvoltage detected	$\overline{CE} = \text{Low}$ , $V_{IN} > 4.4\text{V}$ . Time measured from $V_{VBAT}$ rising from 4.1V to 4.4V to $\overline{\text{FAULT}}$ going low.		176		$\mu$ s	
<b>THERMAL PROTECTION</b>							
$T_{J(OFF)}$	Thermal shutdown temperature			140	150	$^{\circ}\text{C}$	
$T_{J(OFF-HYS)}$	Thermal shutdown hysteresis			20		$^{\circ}\text{C}$	
<b>LOGIC LEVELS ON <math>\overline{CE}</math></b>							
$V_{IL}$	Low-level input voltage		0		0.4	V	
$V_{IH}$	High-level input voltage		1.4			V	
$I_{IL}$	Low-level input current	$V_{CE} = 0\text{V}$			1	$\mu$ A	
$I_{IH}$	High-level input current	$V_{CE} = 1.8\text{V}$			15	$\mu$ A	
<b>LOGIC LEVELS ON <math>\overline{\text{FAULT}}</math></b>							
$V_{OL}$	Output low voltage	$I_{SINK} = 5\text{mA}$			0.2	V	
$I_{HI-Z}$	Leakage current, $\overline{\text{FAULT}}$ pin HI-Z	$V_{\overline{\text{FAULT}}} = 5\text{V}$			10	$\mu$ A	

(1) Not tested in production. Specified by design.

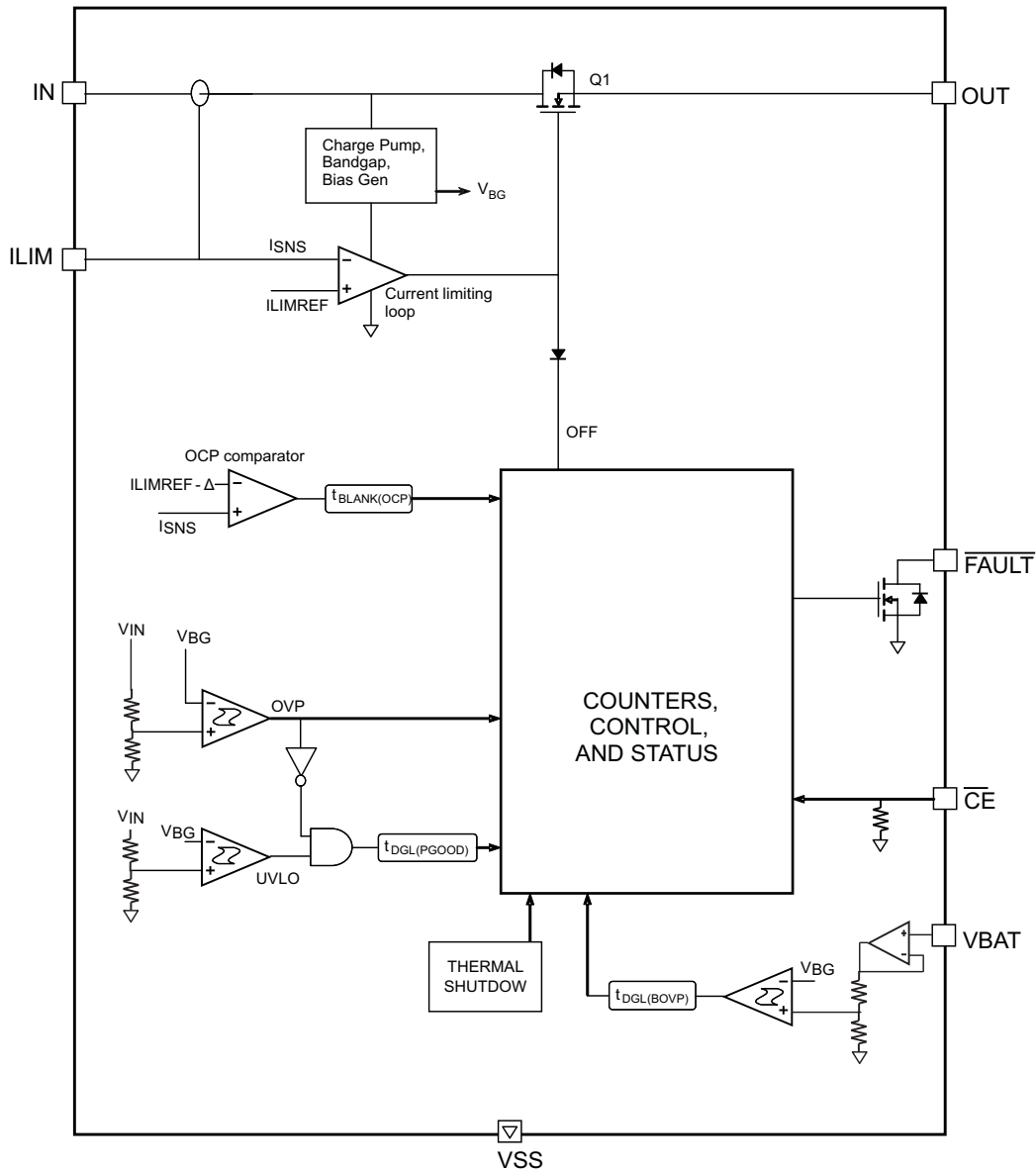
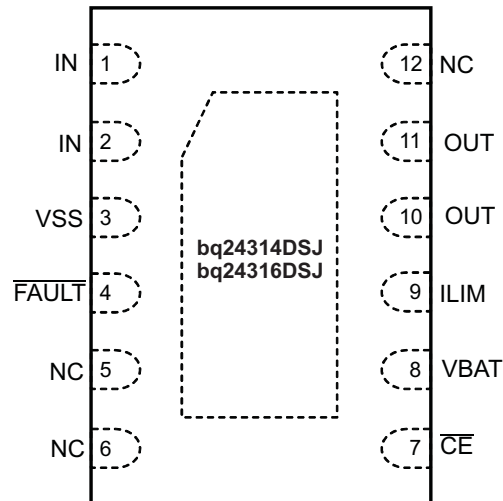
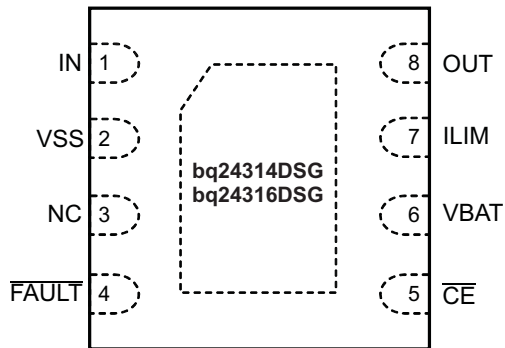


Figure 1. Simplified Block Diagram

## TERMINAL FUNCTIONS

TERMINAL			I/O	DESCRIPTION
NAME	DSJ	DSG		
IN	1, 2	1	I	Input power, connect to external DC supply. Connect external 1µF ceramic capacitor (minimum) to VSS. For the 12 pin (DSJ-suffix) device, ensure that pins 1 and 2 are connected together on the PCB at the device.
OUT	10, 11	8	O	Output terminal to the charging system. Connect external 1µF ceramic capacitor (minimum) to VSS.
VBAT	8	6	I	Battery voltage sense input. Connect to pack positive terminal through a resistor.
ILIM	9	7	I/O	Input overcurrent threshold programming. Connect a resistor to VSS to set the overcurrent threshold.
$\overline{CE}$	7	5	I	Chip enable input. Active low. When $\overline{CE}$ = High, the input FET is off. Internally pulled down.
$\overline{FAULT}$	4	4	O	Open-drain output, device status. $\overline{FAULT}$ = Low indicates that the input FET Q1 has been turned off due to input overvoltage, input overcurrent, battery overvoltage, or thermal shutdown.
VSS	3	2	–	Ground terminal
NC	5, 6, 12	3		These pins may have internal circuits used for test purposes. Do not make any external connections at these pins for normal operation.
Thermal PAD			–	There is an internal electrical connection between the exposed thermal pad and the VSS pin of the device. The thermal pad must be connected to the same potential as the VSS pin on the printed circuit board. Do not use the thermal pad as the primary ground input for the device. The VSS pin must be connected to ground at all times.



### TYPICAL OPERATING PERFORMANCE

Test conditions (unless otherwise noted) for typical operating performance:  $V_{IN} = 5\text{ V}$ ,  $C_{IN} = 1\ \mu\text{F}$ ,  $C_{OUT} = 1\ \mu\text{F}$ ,  $R_{ILIM} = 25\ \text{k}\Omega$ ,  $R_{BAT} = 100\ \text{k}\Omega$ ,  $T_A = 25^\circ\text{C}$ ,  $V_{PU} = 3.3\text{V}$  (see Figure 23 for the Typical Application Circuit)

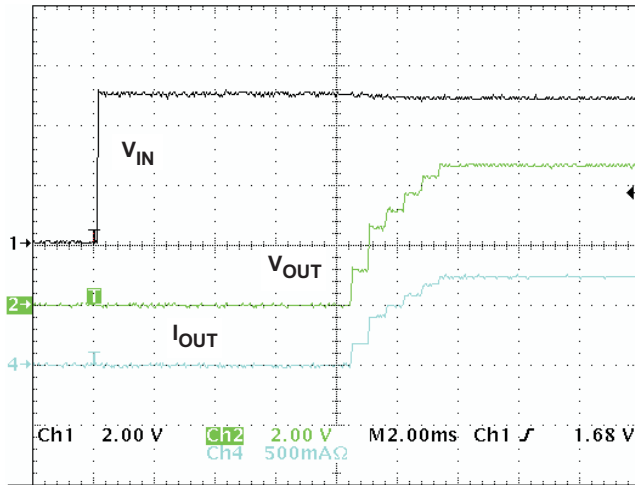


Figure 2. Normal Power-On Showing Soft-Start,  $R_{OUT} = 6.6\Omega$

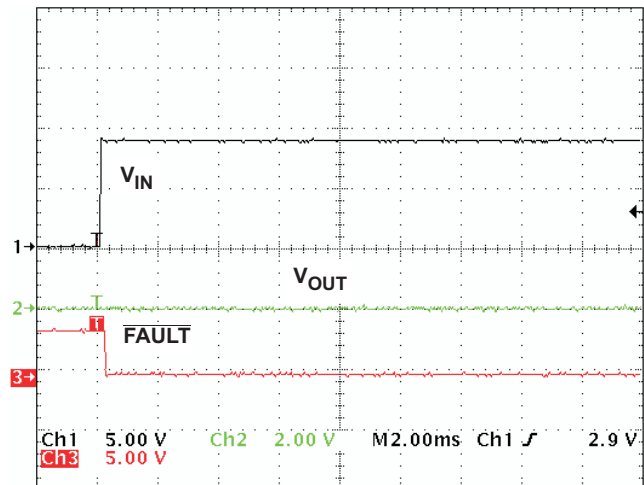


Figure 3. OVP at Power-On,  $V_{IN} = 0\text{V}$  to  $9\text{V}$ ,  $t_r = 50\mu\text{s}$

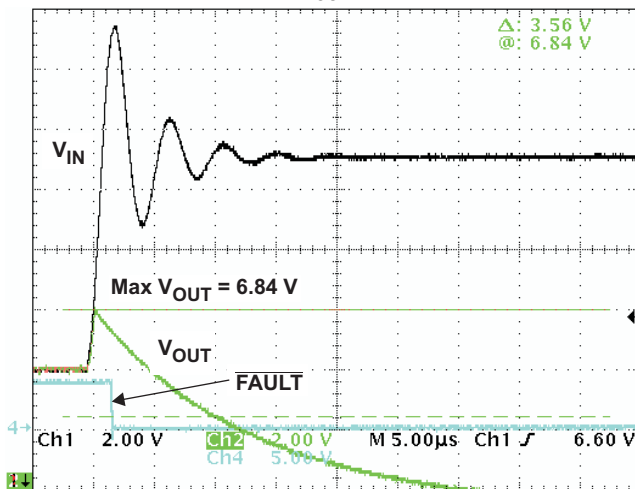


Figure 4. bq24316 OVP Response for Input Step,  $V_{IN} = 5\text{V}$  to  $12\text{V}$ ,  $t_r = 1\mu\text{s}$

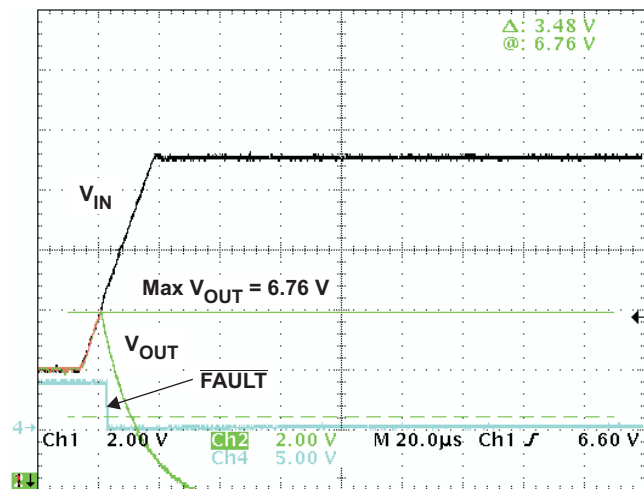


Figure 5. bq24316 OVP Response for Input Step,  $V_{IN} = 5\text{V}$  to  $12\text{V}$ ,  $t_r = 20\mu\text{s}$

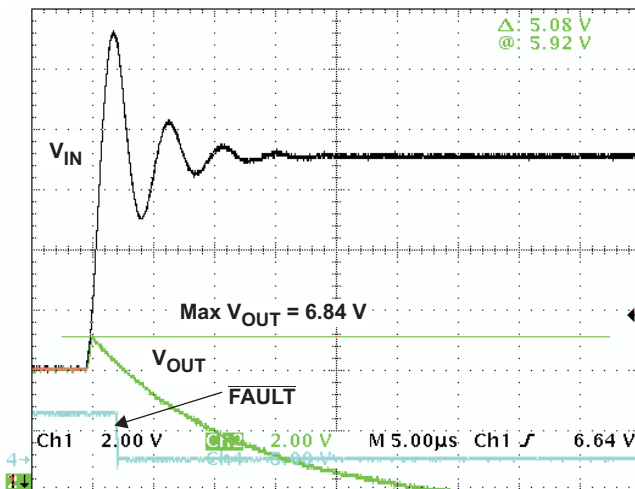


Figure 6. bq24314 OVP Response for Input Step,  $V_{IN} = 5\text{V}$  to  $12\text{V}$ ,  $t_r = 1\mu\text{s}$

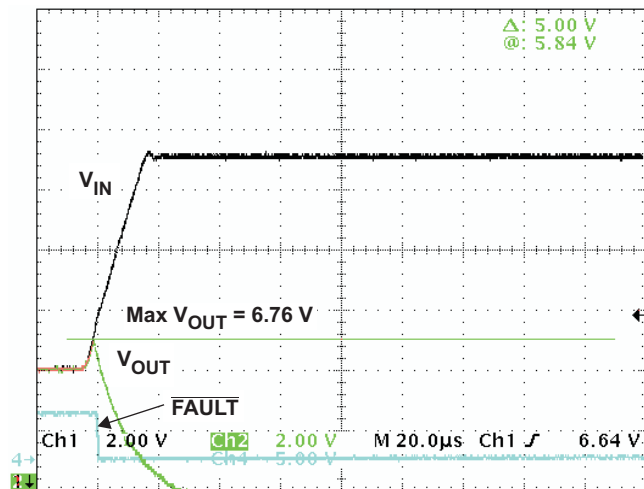


Figure 7. bq24314 OVP Response for Input Step,  $V_{IN} = 5\text{V}$  to  $12\text{V}$ ,  $t_r = 20\mu\text{s}$

TYPICAL OPERATING PERFORMANCE (continued)

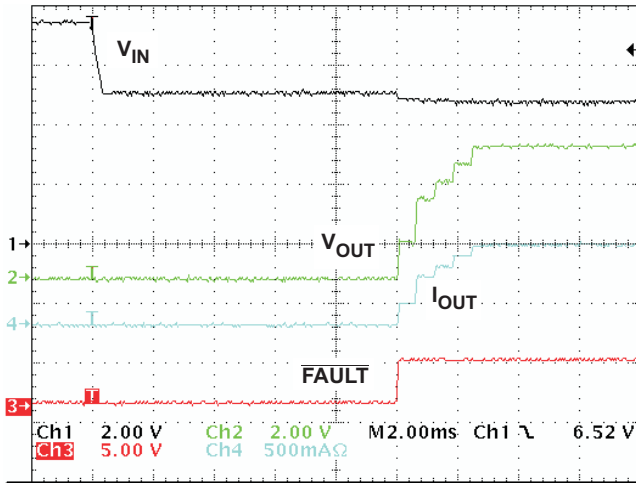


Figure 8. Recovery from OVP,  $V_{IN} = 7.5V$  to  $5V$ ,  $t_f = 400\mu s$

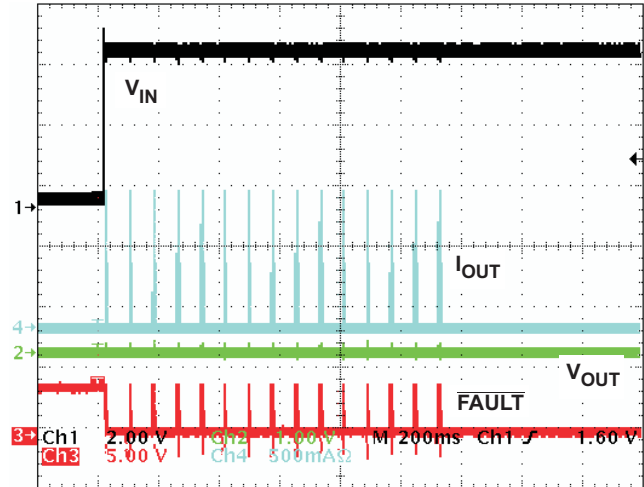


Figure 9. OCP, Powering Up into a Short Circuit on OUT Pin, OCP Counter Counts to 15 Before Switching OFF the Device

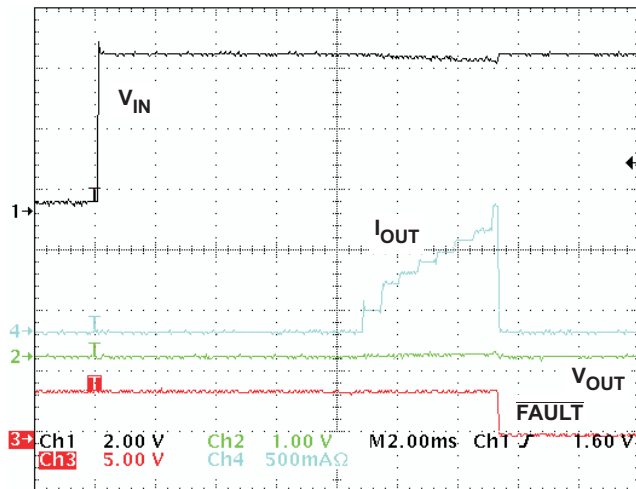


Figure 10. OCP, Zoom-in on the First Cycle of Figure 9

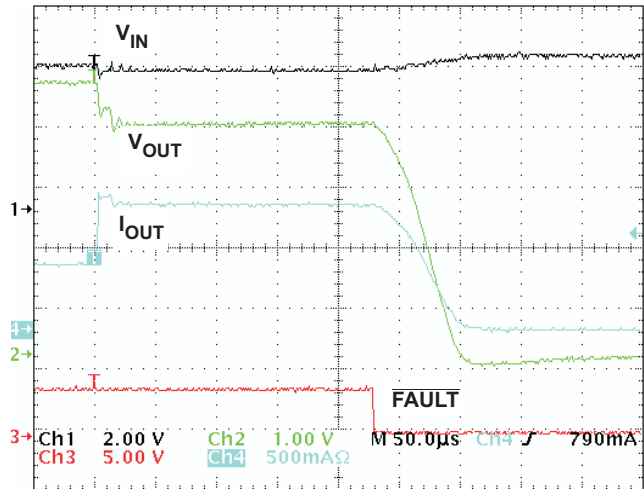


Figure 11. OCP,  $R_{OUT}$  Switches from  $6.6\Omega$  to  $3.3\Omega$ , Shows Current Limiting and Soft-Stop

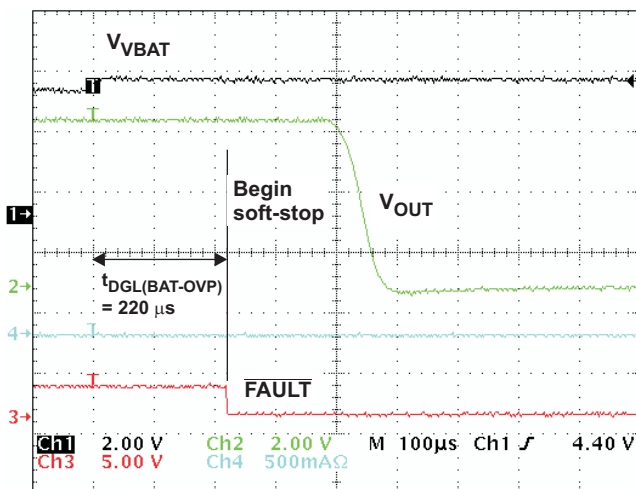


Figure 12. BAT-OVP,  $V_{BAT}$  Steps from  $4.2V$  to  $4.4V$ , Shows  $t_{DGL(BAT-OVP)}$  and Soft-Stop

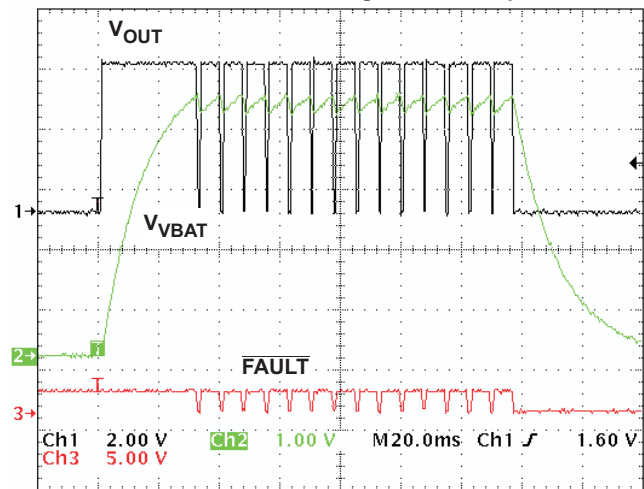
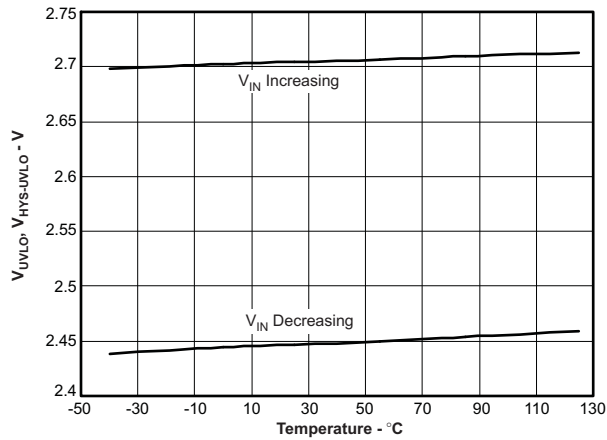


Figure 13. BAT-OVP,  $V_{BAT}$  Cycles Between  $4.1V$  and  $4.4V$ , Shows BAT-OVP Counter

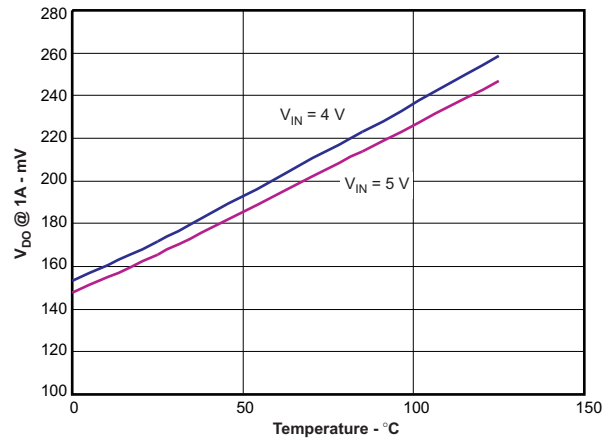
**TYPICAL OPERATING PERFORMANCE (continued)**

**UNDERVOLTAGE LOCKOUT  
vs  
FREE-AIR TEMPERATURE**



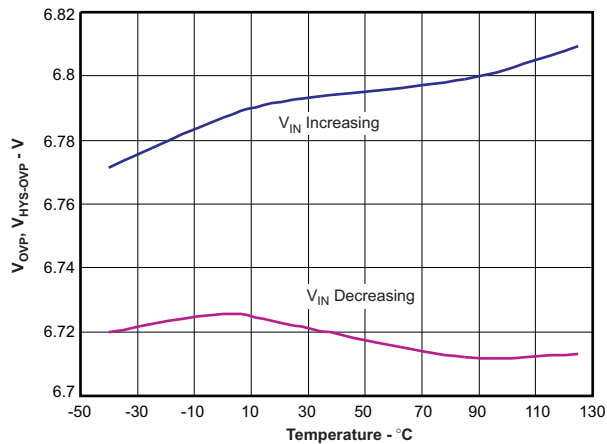
**Figure 14.**

**DROPOUT VOLTAGE (IN to OUT)  
vs  
FREE-AIR TEMPERATURE**



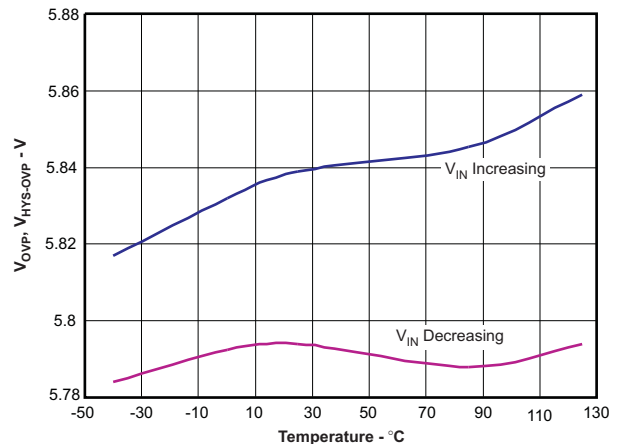
**Figure 15.**

**OVERVOLTAGE THRESHOLD PROTECTION (bq24316)  
vs  
FREE-AIR TEMPERATURE**



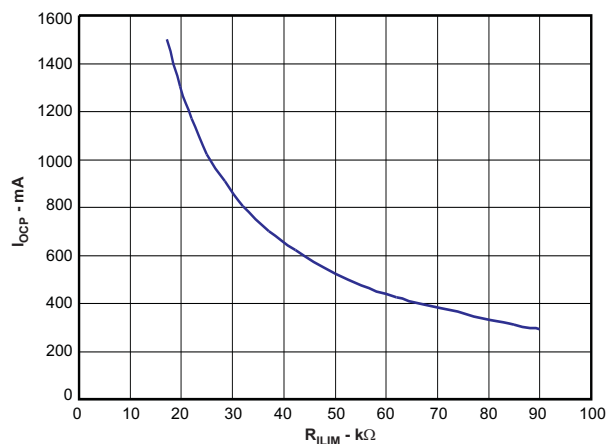
**Figure 16.**

**OVERVOLTAGE THRESHOLD PROTECTION (bq24314)  
vs  
FREE-AIR TEMPERATURE**



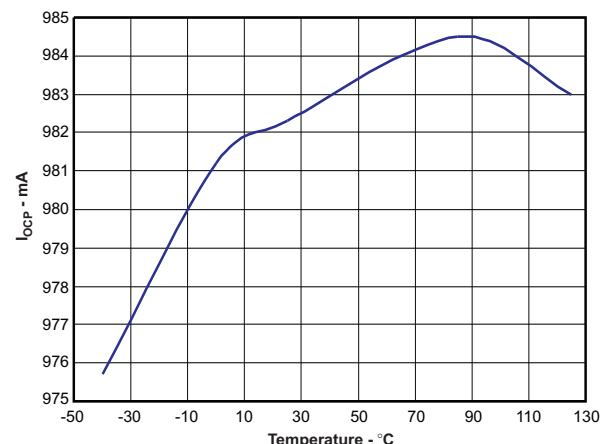
**Figure 17.**

**INPUT OVERCURRENT PROTECTION  
vs  
ILIM RESISTANCE**



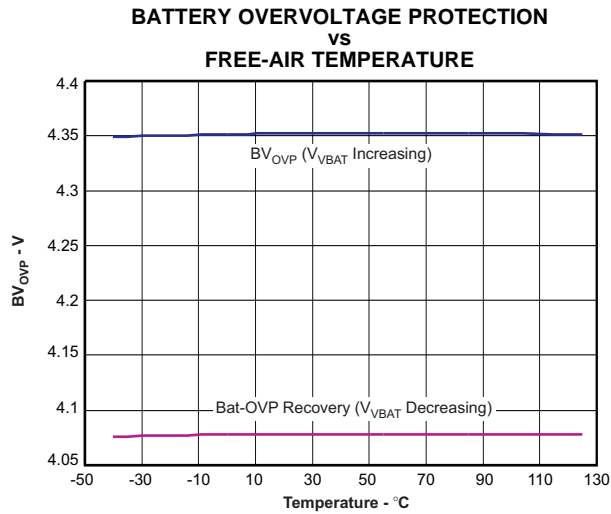
**Figure 18.**

**INPUT OVERCURRENT PROTECTION  
vs  
FREE-AIR TEMPERATURE**

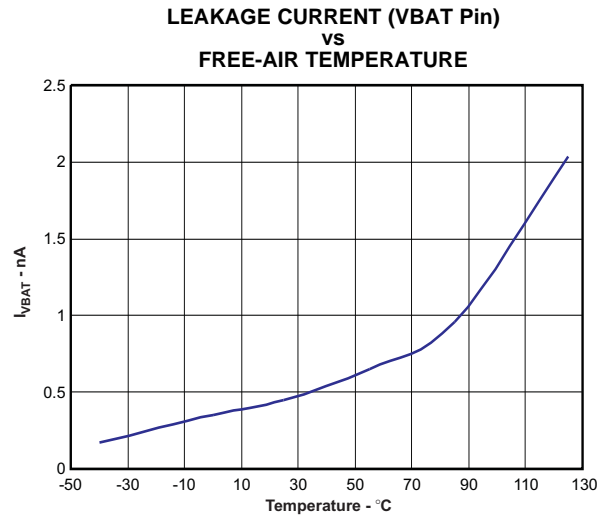


**Figure 19.**

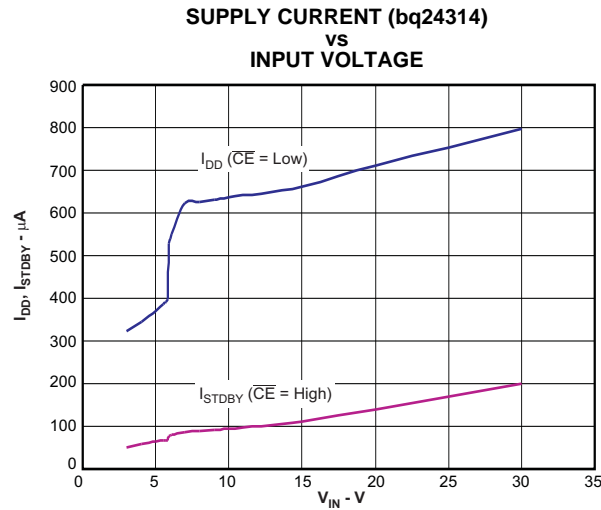
**TYPICAL OPERATING PERFORMANCE (continued)**



**Figure 20.**



**Figure 21.**



**Figure 22.**

## TYPICAL APPLICATION CIRCUIT

$V_{OVP} = 6.8V$ ,  $I_{OCP} = 1000mA$ ,  $BV_{OVP} = 4.35V$  (Terminal numbers shown are for the 2x2 DSG package)

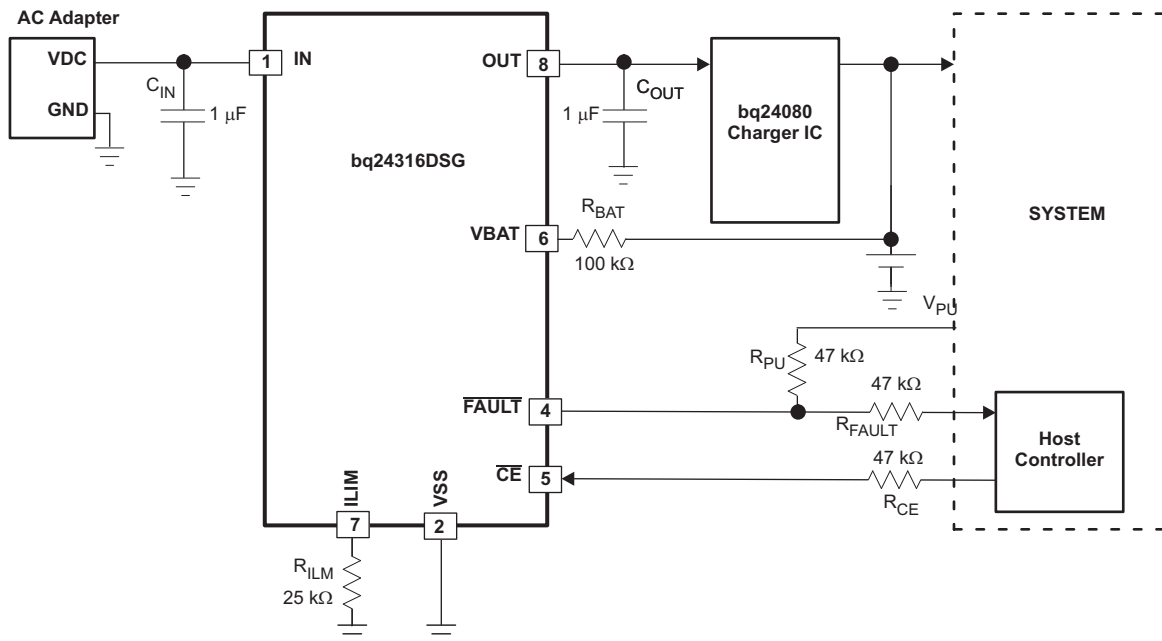


Figure 23.

## DETAILED FUNCTIONAL DESCRIPTION

The bq24314 and bq24316 are highly integrated circuits designed to provide protection to Li-ion batteries from failures of the charging circuit. The IC continuously monitors the input voltage, the input current and the battery voltage. In case of an input overvoltage condition, the IC immediately removes power from the charging circuit by turning off an internal switch. In the case of an overcurrent condition, it limits the system current at the threshold value, and if the overcurrent persists, switches the pass element OFF after a blanking period. If the battery voltage rises to an unsafe level, the IC disconnects power from the charging circuit until the battery voltage returns to an acceptable value. Additionally, the IC also monitors its own die temperature and switches off if it becomes too hot. The input overcurrent threshold is user-programmable. The IC can be controlled by a processor, and also provides status information about fault conditions to the host.

### POWER DOWN

The device remains in power down mode when the input voltage at the IN pin is below the undervoltage threshold  $V_{UVLO}$ . The FET Q1 connected between IN and OUT pins is off, and the status output,  $\overline{FAULT}$ , is set to Hi-Z.

### POWER-ON RESET

The device resets when the input voltage at the IN pin exceeds the UVLO threshold. All internal counters and other circuit blocks are reset. The IC then waits for duration  $t_{DGL(PGOOD)}$  for the input voltage to stabilize. If, after  $t_{DGL(PGOOD)}$ , the input voltage and battery voltage are safe, FET Q1 is turned ON. The IC has a soft-start feature to control the inrush current. The soft-start minimizes the ringing at the input (the ringing occurs because the parasitic inductance of the adapter cable and the input bypass capacitor form a resonant circuit). Figure 2 shows the power-up behavior of the device. Because of the deglitch time at power-on, if the input voltage rises rapidly to beyond the OVP threshold, the device will not switch on at all, instead it will go into protection mode and indicate a fault on the FAULT pin, as shown in Figure 3.

## OPERATION

The device continuously monitors the input voltage, the input current, and the battery voltage as described in detail in the following sections.

### Input Overvoltage Protection

If the input voltage rises above  $V_{OVP}$ , the internal FET Q1 is turned off, removing power from the circuit. As shown in [Figure 4](#) to [Figure 7](#), the response is very rapid, with the FET turning off in less than a microsecond. The  $\overline{\text{FAULT}}$  pin is driven low. When the input voltage returns below  $V_{OVP} - V_{HYS-OVP}$  (but is still above  $V_{UVLO}$ ), the FET Q1 is turned on again after a deglitch time of  $t_{ON(OVP)}$  to ensure that the input supply has stabilized. [Figure 8](#) shows the recovery from input OVP.

### Input Overcurrent Protection

The overcurrent threshold is programmed by a resistor  $R_{ILIM}$  connected from the ILIM pin to VSS. [Figure 18](#) shows the OCP threshold as a function of  $R_{ILIM}$ , and may be approximated by the following equation:  $I_{OCP} = 25 \div R_{ILIM}$  (current in A, resistance in  $k\Omega$ )

If the load current tries to exceed the  $I_{OCP}$  threshold, the device limits the current for a blanking duration of  $t_{BLANK(OCP)}$ . If the load current returns to less than  $I_{OCP}$  before  $t_{BLANK(OCP)}$  times out, the device continues to operate. However, if the overcurrent situation persists for  $t_{BLANK(OCP)}$ , the FET Q1 is turned off for a duration of  $t_{REC(OCP)}$ , and the  $\overline{\text{FAULT}}$  pin is driven low. The FET is then turned on again after  $t_{REC(OCP)}$  and the current is monitored all over again. Each time an OCP fault occurs, an internal counter is incremented. If 15 OCP faults occur in one charge cycle, the FET is turned off permanently. The counter is cleared either by removing and re-applying input power, or by disabling and re-enabling the device with the  $\overline{\text{CE}}$  pin. [Figure 9](#) to [Figure 11](#) show what happens in an overcurrent fault.

To prevent the input voltage from spiking up due to the inductance of the input cable, Q1 is turned off slowly, resulting in a “soft-stop”, as shown in [Figure 11](#).

### Battery Overvoltage Protection

The battery overvoltage threshold  $BV_{OVP}$  is internally set to 4.35V. If the battery voltage exceeds the  $BV_{OVP}$  threshold, the FET Q1 is turned off, and the  $\overline{\text{FAULT}}$  pin is driven low. The FET is turned back on once the battery voltage drops to  $BV_{OVP} - V_{HYS-BOVP}$  (see [Figure 12](#) and [Figure 13](#)). Each time a battery overvoltage fault occurs, an internal counter is incremented. If 15 such faults occur in one charge cycle, the FET is turned off permanently. The counter is cleared either by removing and re-applying input power, or by disabling and re-enabling the device with the  $\overline{\text{CE}}$  pin. In the case of a battery overvoltage fault, Q1 is switched OFF gradually (see [Figure 12](#)).

### Thermal Protection

If the junction temperature of the device exceeds  $T_{J(OFF)}$ , the FET Q1 is turned off, and the  $\overline{\text{FAULT}}$  pin is driven low. The FET is turned back on when the junction temperature falls below  $T_{J(OFF)} - T_{J(OFF-HYS)}$ .

### Enable Function

The IC has an enable pin which can be used to enable or disable the device. When the  $\overline{\text{CE}}$  pin is driven high, the internal FET is turned off. When the  $\overline{\text{CE}}$  pin is low, the FET is turned on if other conditions are safe. The OCP counter and the Bat-OVP counter are both reset when the device is disabled and re-enabled. The  $\overline{\text{CE}}$  pin has an internal pulldown resistor and can be left floating. Note that the  $\overline{\text{FAULT}}$  pin functionality is also disabled when the  $\overline{\text{CE}}$  pin is high.

### Fault Indication

The  $\overline{\text{FAULT}}$  pin is an active-low open-drain output. It is in a high-impedance state when operating conditions are safe, or when the device is disabled by setting  $\overline{\text{CE}}$  high. With  $\overline{\text{CE}}$  low, the  $\overline{\text{FAULT}}$  pin goes low whenever any of these events occurs:

- Input overvoltage
- Input overcurrent
- Battery overvoltage
- IC Overtemperature

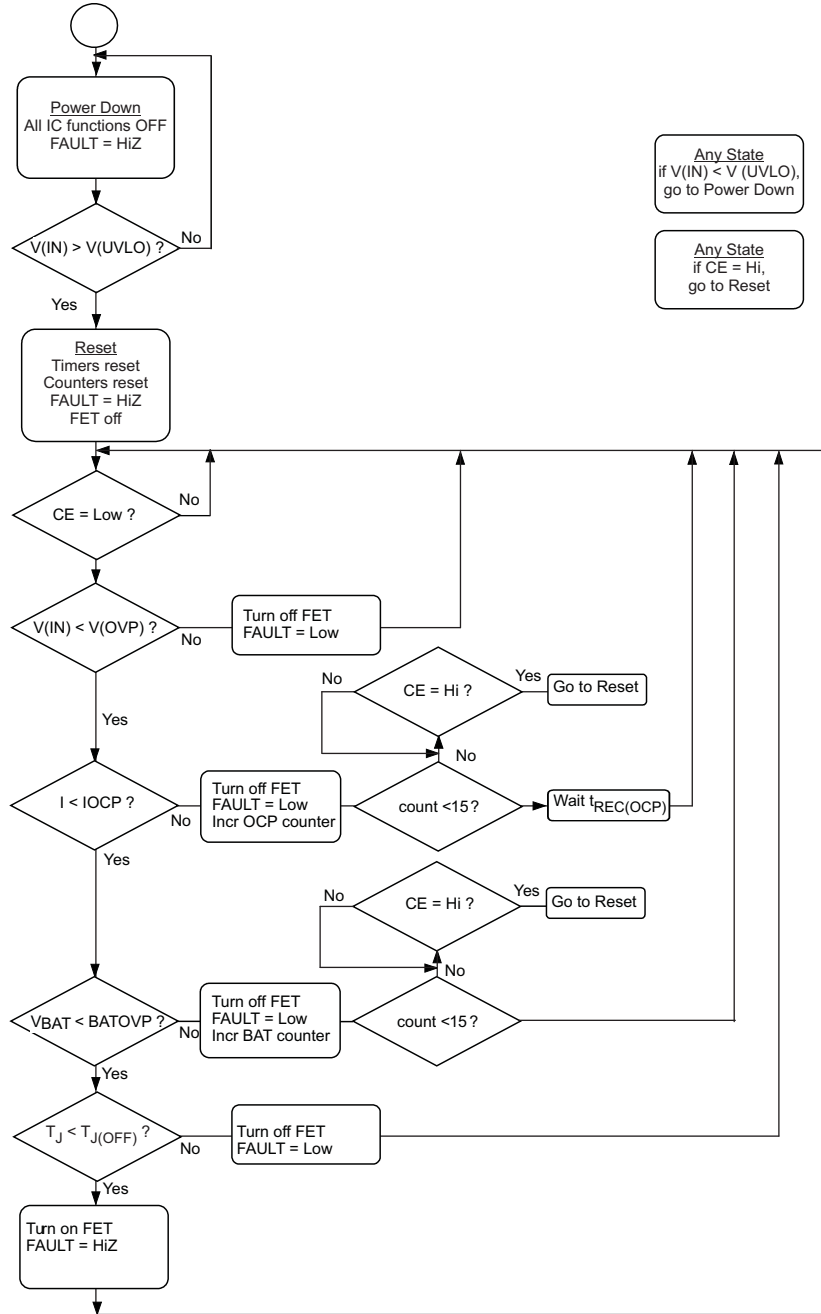


Figure 24. Flow Diagram

## APPLICATION INFORMATION (WITH REFERENCE TO [FIGURE 23](#))

### Selection of $R_{BAT}$

It is strongly recommended that the battery not be tied directly to the VBAT pin of the device, as under some failure modes of the IC, the voltage at the IN pin may appear on the VBAT pin. This voltage can be as high as 30V, and applying 30V to the battery in case of the failure of the bq2431x can be hazardous. Connecting the VBAT pin through  $R_{BAT}$  prevents a large current from flowing into the battery in case of a failure of the IC. In the interests of safety,  $R_{BAT}$  should have a very high value. The problem with a large  $R_{BAT}$  is that the voltage drop across this resistor because of the VBAT bias current  $I_{VBAT}$  causes an error in the  $BV_{OVP}$  threshold. This error is over and above the tolerance on the nominal 4.35V  $BV_{OVP}$  threshold.

Choosing  $R_{BAT}$  in the range 100k $\Omega$  to 470k $\Omega$  is a good compromise. In the case of an IC failure, with  $R_{BAT}$  equal to 100k $\Omega$ , the maximum current flowing into the battery would be  $(30V - 3V) \div 100k\Omega = 246\mu A$ , which is low enough to be absorbed by the bias currents of the system components.  $R_{BAT}$  equal to 100k $\Omega$  would result in a worst-case voltage drop of  $R_{BAT} \times I_{VBAT} = 1mV$ . This is negligible compared to the internal tolerance of 50mV on  $BV_{OVP}$  threshold.

If the Bat-OVP function is not required, the VBAT pin should be connected to VSS.

### Selection of $R_{CE}$ , $R_{FAULT}$ , and $R_{PU}$

The  $\overline{CE}$  pin can be used to enable and disable the IC. If host control is not required, the  $\overline{CE}$  pin can be tied to ground or left un-connected, permanently enabling the device.

In applications where external control is required, the  $\overline{CE}$  pin can be controlled by a host processor. As in the case of the VBAT pin (see above), the  $\overline{CE}$  pin should be connected to the host GPIO pin through as large a resistor as possible. The limitation on the resistor value is that the minimum  $V_{OH}$  of the host GPIO pin less the drop across the resistor should be greater than  $V_{IH}$  of the bq2431x  $\overline{CE}$  pin. The drop across the resistor is given by  $R_{CE} \times I_{IH}$ .

The  $\overline{FAULT}$  pin is an open-drain output that goes low during OV, OC, battery-OV, and OT events. If the application does not require monitoring of the  $\overline{FAULT}$  pin, it can be left unconnected. But if the  $\overline{FAULT}$  pin has to be monitored, it should be pulled high externally through  $R_{PU}$ , and connected to the host through  $R_{FAULT}$ .  $R_{FAULT}$  prevents damage to the host controller if the bq2431x fails (see above). The resistors should be of high value, in practice values between 22k $\Omega$  and 100k $\Omega$  should be sufficient.

### Selection of Input and Output Bypass Capacitors

The input capacitor  $C_{IN}$  in [Figure 23](#) is for decoupling, and serves an important purpose. Whenever there is a step change downwards in the system load current, the inductance of the input cable causes the input voltage to spike up.  $C_{IN}$  prevents the input voltage from overshooting to dangerous levels. It is strongly recommended that a ceramic capacitor of at least 1 $\mu F$  be used at the input of the device. It should be located in close proximity to the IN pin.

$C_{OUT}$  in [Figure 23](#) is also important: If a very fast ( $< 1\mu s$  rise time) overvoltage transient occurs at the input, the current that charges  $C_{OUT}$  causes the device's current-limiting loop to kick in, reducing the gate-drive to FET Q1. This results in improved performance for input overvoltage protection.  $C_{OUT}$  should also be a ceramic capacitor of at least 1 $\mu F$ , located close to the OUT pin.  $C_{OUT}$  also serves as the input decoupling capacitor for the charging circuit downstream of the protection IC.

### Powering Accessories

In some applications, the equipment that the protection IC resides in may be required to provide power to an accessory (e.g. a cellphone may power a headset or an external memory card) through the same connector pins that are used by the adapter for charging. [Figure 25](#) and [Figure 26](#) illustrate typical charging and accessory-powering scenarios:

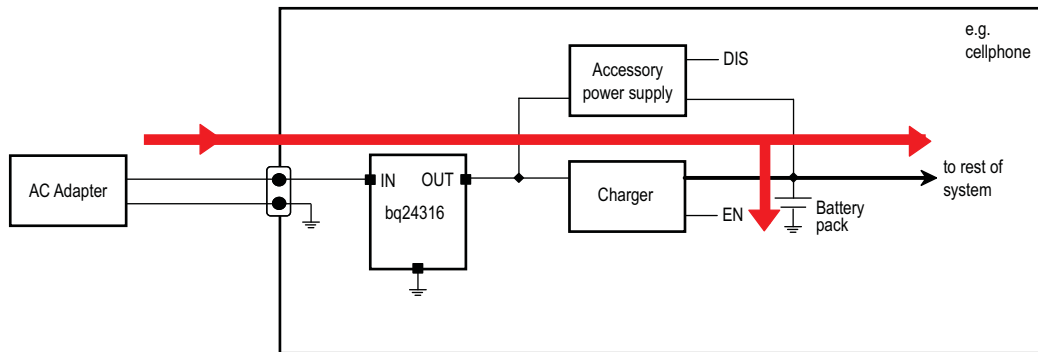


Figure 25. Charging - The Red Arrows Show the Direction of Current Flow

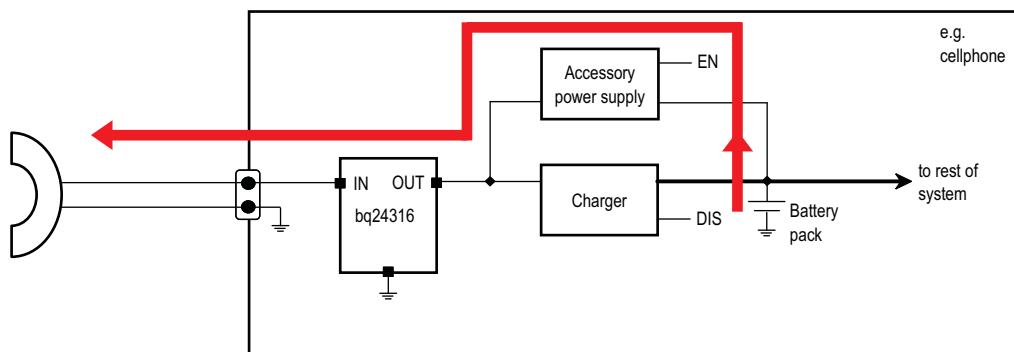


Figure 26. Powering an Accessory - The Red Arrows Show the Direction of Current Flow

In the second case, when power is being delivered to an accessory, the bq24314/bq24316 device is required to support current flow from the OUT pin to the IN pin.

If  $V_{OUT} > V_{UVLO} + 0.7V$ , FET Q1 is turned on, and the reverse current does not flow through the diode but through Q1. Q1 will then remain ON as long as  $V_{OUT} > V_{UVLO} - V_{HYS-UVLO} + R_{DS(ON)} * I_{ACCESSORY}$ . Within this voltage range, the reverse current capability is the same as the forward capability, 1.5A. It should be noted that there is no overcurrent protection in this direction.

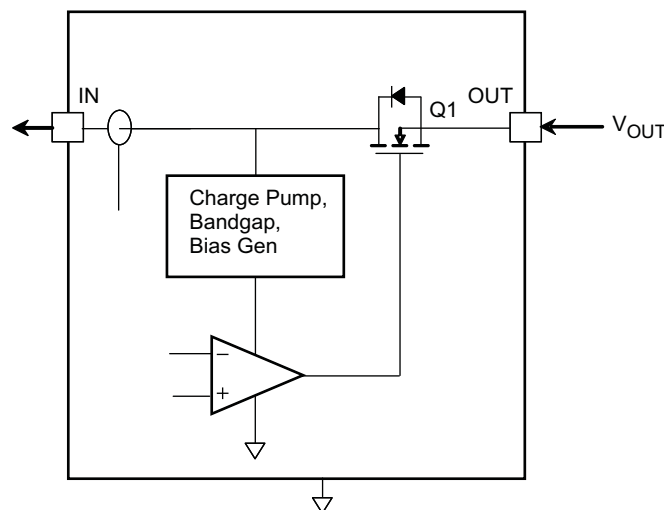


Figure 27.

### **PCB Layout Guidelines:**

- This device is a protection device, and is meant to protect down-stream circuitry from hazardous voltages. Potentially, high voltages may be applied to this IC. It has to be ensured that the edge-to-edge clearances of PCB traces satisfy the design rules for high voltages.
- The device uses SON packages with a PowerPAD™. For good thermal performance, the PowerPAD should be thermally coupled with the PCB ground plane. In most applications, this will require a copper pad directly under the IC. This copper pad should be connected to the ground plane with an array of thermal vias.
- $C_{IN}$  and  $C_{OUT}$  should be located close to the IC. Other components like  $R_{ILIM}$  and  $R_{BAT}$  should also be located close to the IC.

## Revision History

Changes from Revision B (September 2007) to Revision C	Page
• Changed bq24314DSJ marking from preview to CBX .....	2
• Changed bq24316DSJ marking from preview to BZC.....	2

**PACKAGING INFORMATION**

Orderable Device	Status (1)	Package Type	Package Drawing	Pins	Package Qty	Eco Plan (2)	Lead/Ball Finish (6)	MSL Peak Temp (3)	Op Temp (°C)	Device Marking (4/5)	Samples
BQ24314DSGR	ACTIVE	WSO	DSG	8	3000	Green (RoHS & no Sb/Br)	CU NIPDAU	Level-2-260C-1 YEAR	-40 to 85	CBV	<a href="#">Samples</a>
BQ24314DSGRG4	ACTIVE	WSO	DSG	8	3000	Green (RoHS & no Sb/Br)	CU NIPDAU	Level-2-260C-1 YEAR	-40 to 85	CBV	<a href="#">Samples</a>
BQ24314DSGT	ACTIVE	WSO	DSG	8	250	Green (RoHS & no Sb/Br)	CU NIPDAU	Level-2-260C-1 YEAR	-40 to 85	CBV	<a href="#">Samples</a>
BQ24314DSJR	ACTIVE	VSO	DSJ	12	3000	Green (RoHS & no Sb/Br)	CU NIPDAU	Level-2-260C-1 YEAR	-40 to 85	CBX	<a href="#">Samples</a>
BQ24314DSJT	ACTIVE	VSO	DSJ	12	250	Green (RoHS & no Sb/Br)	CU NIPDAU	Level-2-260C-1 YEAR	-40 to 85	CBX	<a href="#">Samples</a>
BQ24316DSGR	ACTIVE	WSO	DSG	8	3000	Green (RoHS & no Sb/Br)	CU NIPDAU	Level-2-260C-1 YEAR	-40 to 85	CBW	<a href="#">Samples</a>
BQ24316DSGT	ACTIVE	WSO	DSG	8	250	Green (RoHS & no Sb/Br)	CU NIPDAU	Level-2-260C-1 YEAR	-40 to 85	CBW	<a href="#">Samples</a>
BQ24316DSGTG4	ACTIVE	WSO	DSG	8	250	Green (RoHS & no Sb/Br)	CU NIPDAU	Level-2-260C-1 YEAR	-40 to 85	CBW	<a href="#">Samples</a>
BQ24316DSJR	ACTIVE	VSO	DSJ	12	3000	Green (RoHS & no Sb/Br)	CU NIPDAU	Level-2-260C-1 YEAR	-40 to 85	BZC	<a href="#">Samples</a>
BQ24316DSJT	ACTIVE	VSO	DSJ	12	250	Green (RoHS & no Sb/Br)	CU NIPDAU	Level-2-260C-1 YEAR	-40 to 85	BZC	<a href="#">Samples</a>

(1) The marketing status values are defined as follows:

**ACTIVE:** Product device recommended for new designs.

**LIFEBUY:** TI has announced that the device will be discontinued, and a lifetime-buy period is in effect.

**NRND:** Not recommended for new designs. Device is in production to support existing customers, but TI does not recommend using this part in a new design.

**PREVIEW:** Device has been announced but is not in production. Samples may or may not be available.

**OBSELETE:** TI has discontinued the production of the device.

(2) Eco Plan - The planned eco-friendly classification: Pb-Free (RoHS), Pb-Free (RoHS Exempt), or Green (RoHS & no Sb/Br) - please check <http://www.ti.com/productcontent> for the latest availability information and additional product content details.

**TBD:** The Pb-Free/Green conversion plan has not been defined.

**Pb-Free (RoHS):** TI's terms "Lead-Free" or "Pb-Free" mean semiconductor products that are compatible with the current RoHS requirements for all 6 substances, including the requirement that lead not exceed 0.1% by weight in homogeneous materials. Where designed to be soldered at high temperatures, TI Pb-Free products are suitable for use in specified lead-free processes.

**Pb-Free (RoHS Exempt):** This component has a RoHS exemption for either 1) lead-based flip-chip solder bumps used between the die and package, or 2) lead-based die adhesive used between the die and leadframe. The component is otherwise considered Pb-Free (RoHS compatible) as defined above.

**Green (RoHS & no Sb/Br):** TI defines "Green" to mean Pb-Free (RoHS compatible), and free of Bromine (Br) and Antimony (Sb) based flame retardants (Br or Sb do not exceed 0.1% by weight in homogeneous material)

- (3) MSL, Peak Temp. - The Moisture Sensitivity Level rating according to the JEDEC industry standard classifications, and peak solder temperature.
- (4) There may be additional marking, which relates to the logo, the lot trace code information, or the environmental category on the device.
- (5) Multiple Device Markings will be inside parentheses. Only one Device Marking contained in parentheses and separated by a "~" will appear on a device. If a line is indented then it is a continuation of the previous line and the two combined represent the entire Device Marking for that device.
- (6) Lead/Ball Finish - Orderable Devices may have multiple material finish options. Finish options are separated by a vertical ruled line. Lead/Ball Finish values may wrap to two lines if the finish value exceeds the maximum column width.

**Important Information and Disclaimer:**The information provided on this page represents TI's knowledge and belief as of the date that it is provided. TI bases its knowledge and belief on information provided by third parties, and makes no representation or warranty as to the accuracy of such information. Efforts are underway to better integrate information from third parties. TI has taken and continues to take reasonable steps to provide representative and accurate information but may not have conducted destructive testing or chemical analysis on incoming materials and chemicals. TI and TI suppliers consider certain information to be proprietary, and thus CAS numbers and other limited information may not be available for release.

In no event shall TI's liability arising out of such information exceed the total purchase price of the TI part(s) at issue in this document sold by TI to Customer on an annual basis.

**TAPE AND REEL INFORMATION**

**QUADRANT ASSIGNMENTS FOR PIN 1 ORIENTATION IN TAPE**


\*All dimensions are nominal

Device	Package Type	Package Drawing	Pins	SPQ	Reel Diameter (mm)	Reel Width W1 (mm)	A0 (mm)	B0 (mm)	K0 (mm)	P1 (mm)	W (mm)	Pin1 Quadrant
BQ24314DSGR	WSON	DSG	8	3000	180.0	8.4	2.3	2.3	1.15	4.0	8.0	Q2
BQ24314DSGR	WSON	DSG	8	3000	179.0	8.4	2.2	2.2	1.2	4.0	8.0	Q2
BQ24314DSGT	WSON	DSG	8	250	179.0	8.4	2.2	2.2	1.2	4.0	8.0	Q2
BQ24314DSGT	WSON	DSG	8	250	180.0	8.4	2.3	2.3	1.15	4.0	8.0	Q2
BQ24314DSJR	VSON	DSJ	12	3000	330.0	12.4	3.3	4.3	1.1	8.0	12.0	Q1
BQ24314DSJT	VSON	DSJ	12	250	180.0	12.4	3.3	4.3	1.1	8.0	12.0	Q1
BQ24316DSGR	WSON	DSG	8	3000	179.0	8.4	2.2	2.2	1.2	4.0	8.0	Q2
BQ24316DSGT	WSON	DSG	8	250	179.0	8.4	2.2	2.2	1.2	4.0	8.0	Q2
BQ24316DSJR	VSON	DSJ	12	3000	330.0	12.4	3.3	4.3	1.1	8.0	12.0	Q1
BQ24316DSJT	VSON	DSJ	12	250	180.0	12.4	3.3	4.3	1.1	8.0	12.0	Q1

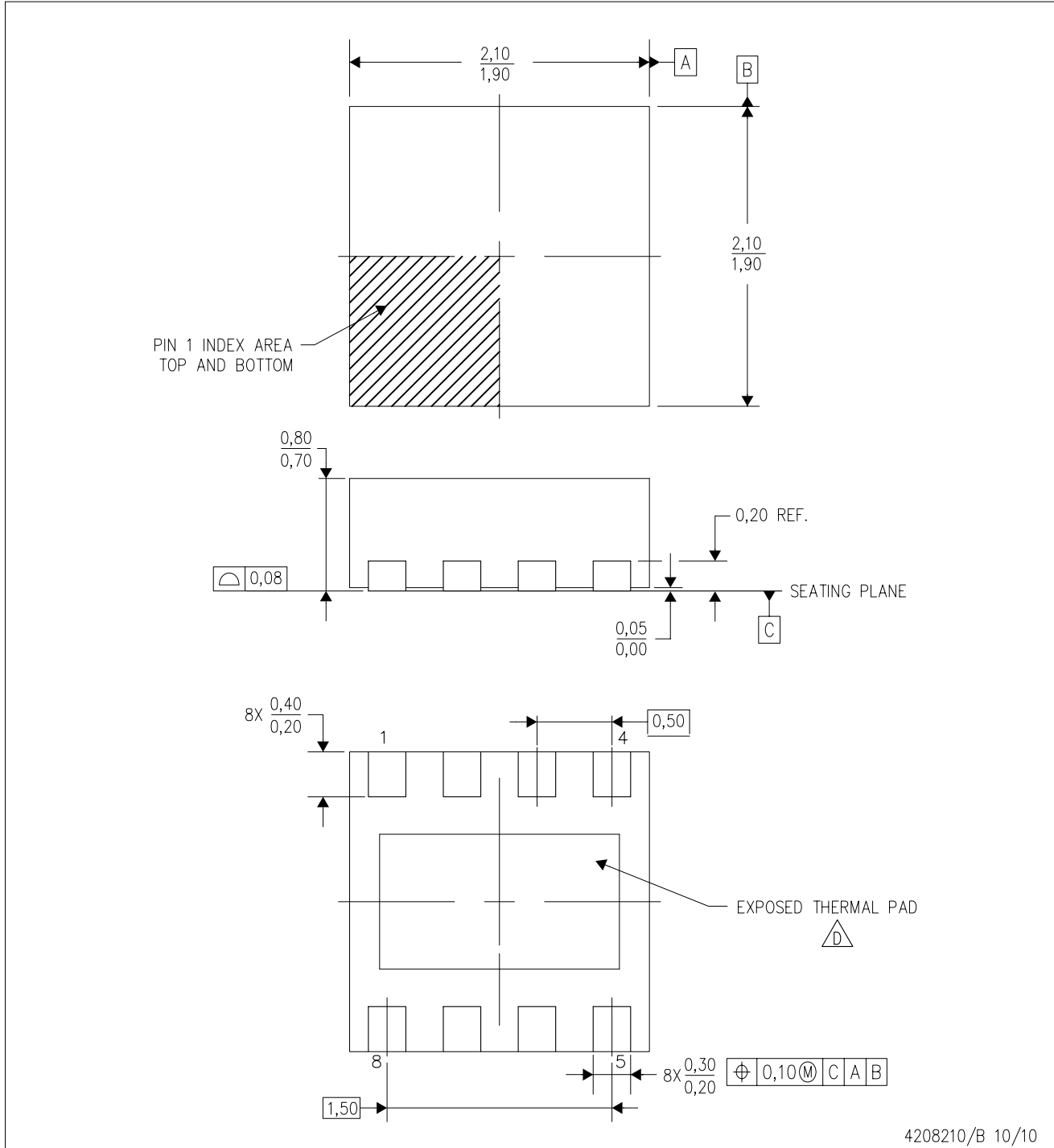
**TAPE AND REEL BOX DIMENSIONS**


\*All dimensions are nominal

Device	Package Type	Package Drawing	Pins	SPQ	Length (mm)	Width (mm)	Height (mm)
BQ24314DSGR	WSON	DSG	8	3000	210.0	185.0	35.0
BQ24314DSGR	WSON	DSG	8	3000	195.0	200.0	45.0
BQ24314DSGT	WSON	DSG	8	250	195.0	200.0	45.0
BQ24314DSGT	WSON	DSG	8	250	210.0	185.0	35.0
BQ24314DSJR	VSON	DSJ	12	3000	367.0	367.0	35.0
BQ24314DSJT	VSON	DSJ	12	250	210.0	185.0	35.0
BQ24316DSGR	WSON	DSG	8	3000	195.0	200.0	45.0
BQ24316DSGT	WSON	DSG	8	250	195.0	200.0	45.0
BQ24316DSJR	VSON	DSJ	12	3000	367.0	367.0	35.0
BQ24316DSJT	VSON	DSJ	12	250	210.0	185.0	35.0

DSG (S-PWSON-N8)

PLASTIC SMALL OUTLINE NO-LEAD



4208210/B 10/10

- NOTES:
- A. All linear dimensions are in millimeters. Dimensioning and tolerancing per ASME Y14.5M-1994.
  - B. This drawing is subject to change without notice.
  - C. Quad Flatpack, No-Leads (QFN) package configuration.
  - The package thermal pad must be soldered to the board for thermal and mechanical performance. See the Product Data Sheet for details regarding the exposed thermal pad dimensions.
  - E. Falls within JEDEC MO-229.

## THERMAL PAD MECHANICAL DATA

DSG (S-PWSON-N8)

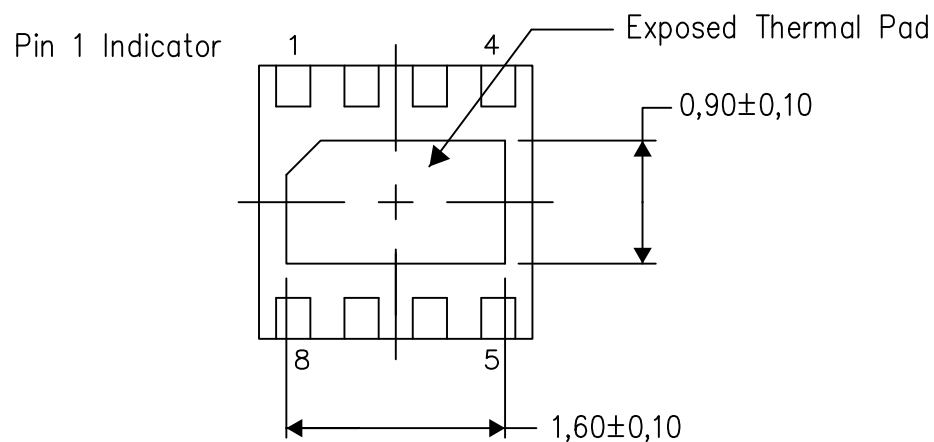
PLASTIC SMALL OUTLINE NO-LEAD

### THERMAL INFORMATION

This package incorporates an exposed thermal pad that is designed to be attached directly to an external heatsink. The thermal pad must be soldered directly to the printed circuit board (PCB). After soldering, the PCB can be used as a heatsink. In addition, through the use of thermal vias, the thermal pad can be attached directly to the appropriate copper plane shown in the electrical schematic for the device, or alternatively, can be attached to a special heatsink structure designed into the PCB. This design optimizes the heat transfer from the integrated circuit (IC).

For information on the Quad Flatpack No-Lead (QFN) package and its advantages, refer to Application Report, QFN/SON PCB Attachment, Texas Instruments Literature No. SLUA271. This document is available at [www.ti.com](http://www.ti.com).

The exposed thermal pad dimensions for this package are shown in the following illustration.

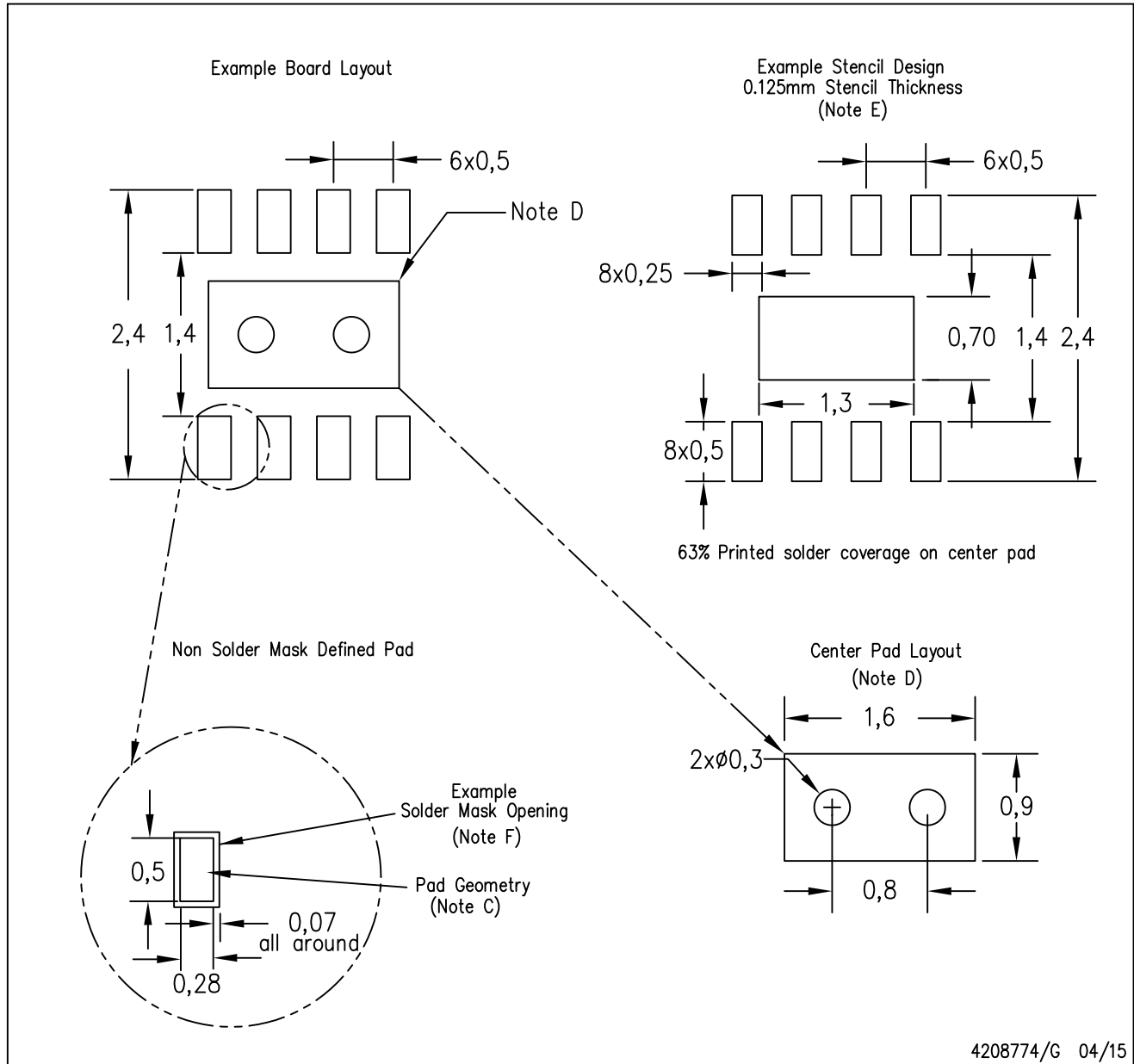


Bottom View

Exposed Thermal Pad Dimensions

4208347/H 04/15

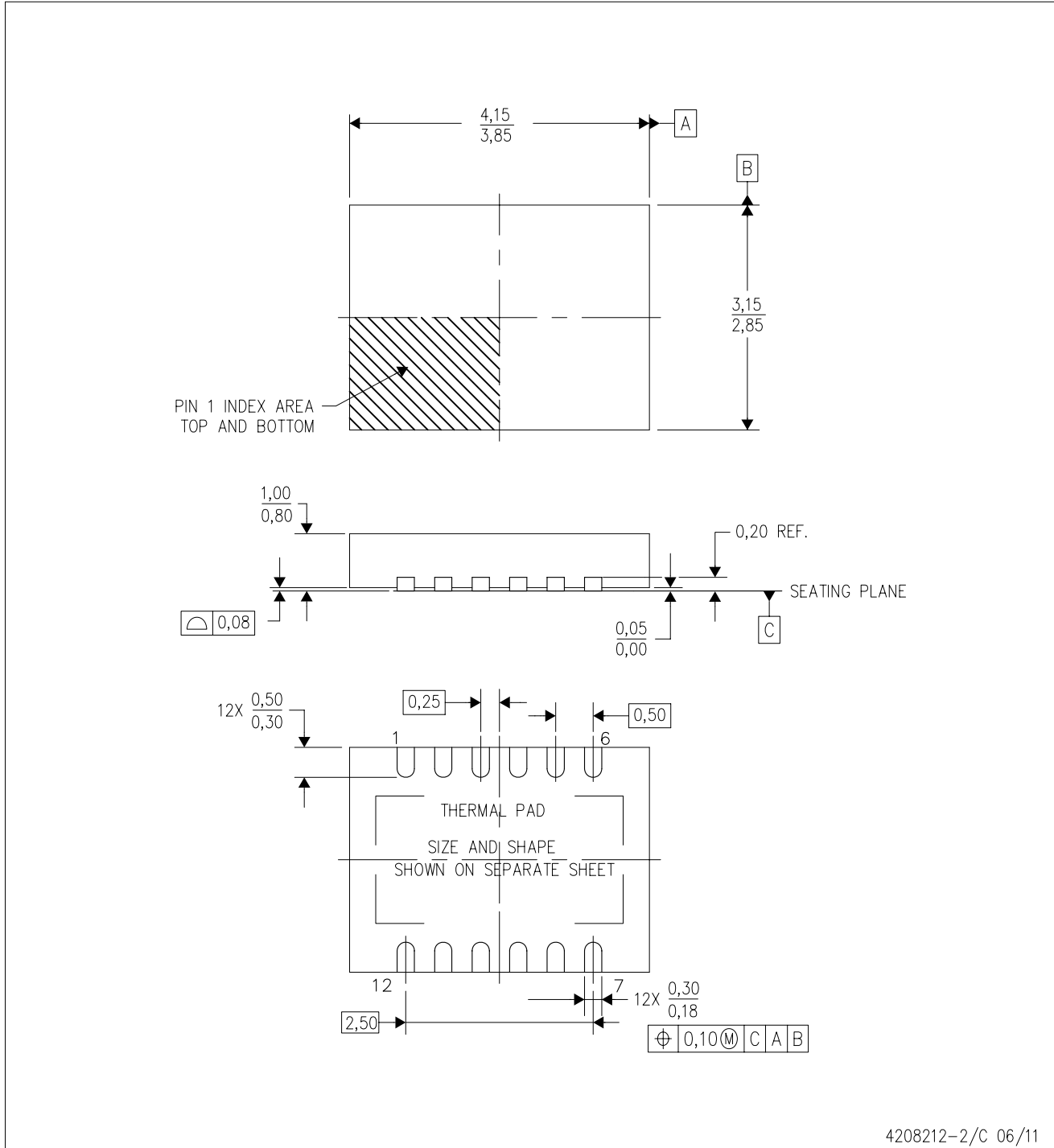
NOTE: All linear dimensions are in millimeters



- NOTES:
- All linear dimensions are in millimeters.
  - This drawing is subject to change without notice.
  - Publication IPC-7351 is recommended for alternate designs.
  - This package is designed to be soldered to a thermal pad on the board. Refer to Application Note, QFN/SON PCB Attachment, Texas Instruments Literature No. SLUA271, and also the Product Data Sheets for specific thermal information, via requirements, and recommended board layout. These documents are available at [www.ti.com](http://www.ti.com) <<http://www.ti.com>>.
  - Laser cutting apertures with trapezoidal walls and also rounding corners will offer better paste release. Customers should contact their board assembly site for stencil design recommendations. Refer to IPC 7525 for stencil design considerations.
  - Customers should contact their board fabrication site for solder mask tolerances.

DSJ (R-PVSON-N12)

PLASTIC SMALL OUTLINE NO-LEAD



4208212-2/C 06/11

- NOTES:
- A. All linear dimensions are in millimeters. Dimensioning and tolerancing per ASME Y14.5M-1994.
  - B. This drawing is subject to change without notice.
  - C. Quad Flatpack, No-Leads (QFN) package configuration.
  - D. The package thermal pad must be soldered to the board for thermal and mechanical performance.
  - E. See the additional figure in the Product Data Sheet for details regarding the exposed thermal pad features and dimensions.
  - F. Falls within JEDEC MO-229.

## THERMAL PAD MECHANICAL DATA

DSJ (R-PVSON-N12)

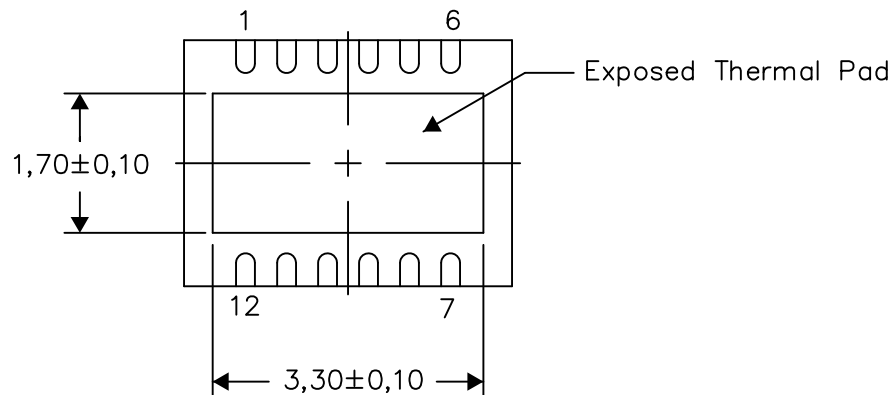
PLASTIC SMALL OUTLINE NO-LEAD

### THERMAL INFORMATION

This package incorporates an exposed thermal pad that is designed to be attached directly to an external heatsink. The thermal pad must be soldered directly to the printed circuit board (PCB). After soldering, the PCB can be used as a heatsink. In addition, through the use of thermal vias, the thermal pad can be attached directly to the appropriate copper plane shown in the electrical schematic for the device, or alternatively, can be attached to a special heatsink structure designed into the PCB. This design optimizes the heat transfer from the integrated circuit (IC).

For information on the Quad Flatpack No-Lead (QFN) package and its advantages, refer to Application Report, QFN/SON PCB Attachment, Texas Instruments Literature No. SLUA271. This document is available at [www.ti.com](http://www.ti.com).

The exposed thermal pad dimensions for this package are shown in the following illustration.



Bottom View

Exposed Thermal Pad Dimensions

4208549-2/G 04/15

NOTE: All linear dimensions are in millimeters

## IMPORTANT NOTICE

Texas Instruments Incorporated and its subsidiaries (TI) reserve the right to make corrections, enhancements, improvements and other changes to its semiconductor products and services per JESD46, latest issue, and to discontinue any product or service per JESD48, latest issue. Buyers should obtain the latest relevant information before placing orders and should verify that such information is current and complete. All semiconductor products (also referred to herein as "components") are sold subject to TI's terms and conditions of sale supplied at the time of order acknowledgment.

TI warrants performance of its components to the specifications applicable at the time of sale, in accordance with the warranty in TI's terms and conditions of sale of semiconductor products. Testing and other quality control techniques are used to the extent TI deems necessary to support this warranty. Except where mandated by applicable law, testing of all parameters of each component is not necessarily performed.

TI assumes no liability for applications assistance or the design of Buyers' products. Buyers are responsible for their products and applications using TI components. To minimize the risks associated with Buyers' products and applications, Buyers should provide adequate design and operating safeguards.

TI does not warrant or represent that any license, either express or implied, is granted under any patent right, copyright, mask work right, or other intellectual property right relating to any combination, machine, or process in which TI components or services are used. Information published by TI regarding third-party products or services does not constitute a license to use such products or services or a warranty or endorsement thereof. Use of such information may require a license from a third party under the patents or other intellectual property of the third party, or a license from TI under the patents or other intellectual property of TI.

Reproduction of significant portions of TI information in TI data books or data sheets is permissible only if reproduction is without alteration and is accompanied by all associated warranties, conditions, limitations, and notices. TI is not responsible or liable for such altered documentation. Information of third parties may be subject to additional restrictions.

Resale of TI components or services with statements different from or beyond the parameters stated by TI for that component or service voids all express and any implied warranties for the associated TI component or service and is an unfair and deceptive business practice. TI is not responsible or liable for any such statements.

Buyer acknowledges and agrees that it is solely responsible for compliance with all legal, regulatory and safety-related requirements concerning its products, and any use of TI components in its applications, notwithstanding any applications-related information or support that may be provided by TI. Buyer represents and agrees that it has all the necessary expertise to create and implement safeguards which anticipate dangerous consequences of failures, monitor failures and their consequences, lessen the likelihood of failures that might cause harm and take appropriate remedial actions. Buyer will fully indemnify TI and its representatives against any damages arising out of the use of any TI components in safety-critical applications.

In some cases, TI components may be promoted specifically to facilitate safety-related applications. With such components, TI's goal is to help enable customers to design and create their own end-product solutions that meet applicable functional safety standards and requirements. Nonetheless, such components are subject to these terms.

No TI components are authorized for use in FDA Class III (or similar life-critical medical equipment) unless authorized officers of the parties have executed a special agreement specifically governing such use.

Only those TI components which TI has specifically designated as military grade or "enhanced plastic" are designed and intended for use in military/aerospace applications or environments. Buyer acknowledges and agrees that any military or aerospace use of TI components which have **not** been so designated is solely at the Buyer's risk, and that Buyer is solely responsible for compliance with all legal and regulatory requirements in connection with such use.

TI has specifically designated certain components as meeting ISO/TS16949 requirements, mainly for automotive use. In any case of use of non-designated products, TI will not be responsible for any failure to meet ISO/TS16949.

### Products

Audio	<a href="http://www.ti.com/audio">www.ti.com/audio</a>
Amplifiers	<a href="http://amplifier.ti.com">amplifier.ti.com</a>
Data Converters	<a href="http://dataconverter.ti.com">dataconverter.ti.com</a>
DLP® Products	<a href="http://www.dlp.com">www.dlp.com</a>
DSP	<a href="http://dsp.ti.com">dsp.ti.com</a>
Clocks and Timers	<a href="http://www.ti.com/clocks">www.ti.com/clocks</a>
Interface	<a href="http://interface.ti.com">interface.ti.com</a>
Logic	<a href="http://logic.ti.com">logic.ti.com</a>
Power Mgmt	<a href="http://power.ti.com">power.ti.com</a>
Microcontrollers	<a href="http://microcontroller.ti.com">microcontroller.ti.com</a>
RFID	<a href="http://www.ti-rfid.com">www.ti-rfid.com</a>
OMAP Applications Processors	<a href="http://www.ti.com/omap">www.ti.com/omap</a>
Wireless Connectivity	<a href="http://www.ti.com/wirelessconnectivity">www.ti.com/wirelessconnectivity</a>

### Applications

Automotive and Transportation	<a href="http://www.ti.com/automotive">www.ti.com/automotive</a>
Communications and Telecom	<a href="http://www.ti.com/communications">www.ti.com/communications</a>
Computers and Peripherals	<a href="http://www.ti.com/computers">www.ti.com/computers</a>
Consumer Electronics	<a href="http://www.ti.com/consumer-apps">www.ti.com/consumer-apps</a>
Energy and Lighting	<a href="http://www.ti.com/energy">www.ti.com/energy</a>
Industrial	<a href="http://www.ti.com/industrial">www.ti.com/industrial</a>
Medical	<a href="http://www.ti.com/medical">www.ti.com/medical</a>
Security	<a href="http://www.ti.com/security">www.ti.com/security</a>
Space, Avionics and Defense	<a href="http://www.ti.com/space-avionics-defense">www.ti.com/space-avionics-defense</a>
Video and Imaging	<a href="http://www.ti.com/video">www.ti.com/video</a>

### TI E2E Community

[e2e.ti.com](http://e2e.ti.com)