

Using the TPS22961EVM-067 Single Channel Load Switch IC

The TPS22961EVM-067 evaluation module (EVM) allows the user to connect power to and control the 8pin SON package load switch. Parameters such as the On State resistance, Output Slew Rate and Output Discharge properties can be easily evaluated. [Table 1](#) lists a short description of the load switch performance specifications; refer to the datasheet [SLVSCI4](#) for more details.

Table 1. TPS22961 Slew Rate, Output Current Rating, Enable, and Output Discharge Options

EVM	Device	Slew Rate Typical	VIN (V)	Max. Continuous Current	Enable (ON Pin)	Quick Output Discharge
HVL067	TPS22961	5 μ s with VBIAS = 5V	1.05	6A	Active High	Yes

Contents

1	Introduction	2
1.1	Description	2
1.2	Features	2
2	Electrical Performance	2
3	Schematic	2
4	Layouts	3
4.1	Setup	5
5	Operation	6
6	Test Configurations	6
6.1	On-Resistance (R_{ON}) Test Setup	6
6.2	Slew Rate Test Setup	7
6.3	VOUT Slew Rate Examples	9
7	Bill of Materials (BOM)	11

List of Figures

1	TPS22961EVM-067 Schematic	2
2	TPS22961EVM-067 Top Assembly.....	3
3	TPS22961EVM-067 Top Layout	4
4	TPS22961EVM-067 Bottom Layout	5
5	R_{ON} Setup	7
6	Slew Rate Setup	8
7	TPS22961 Vout t_r Example	9
8	TPS22961 LC1 Filtered t_r Example.....	10

List of Tables

1	TPS22961 Slew Rate, Output Current Rating, Enable, and Output Discharge Options	1
2	Bill of Materials.....	11

1 Introduction

1.1 Description

The TPS22961EVM is a two sided PCB containing the TPS22961 Load Switch Device; The Input and Output connections to the device and the PCB layout routing are capable of handling high continuous currents and provide a low resistance pathway into and out of the device under test. Test point connections allow the EVM User to control the device with user defined test conditions.

1.2 Features

- EVM allows access to the Input, Output and Control pins of the TPS22961 Load Switch Device.
- On board CIN and COUT capacitors.
- On Board Output loading resistor 10Ω.
- VIN input voltage range: 0.8V to 3.0V.
- VBIAS voltage range: 3.0 to 5.5V
- 6A max continuous current.

2 Electrical Performance

Refer to the datasheet [SLVSCI4](#) for detailed electrical characteristics of the TPS22961.

3 Schematic

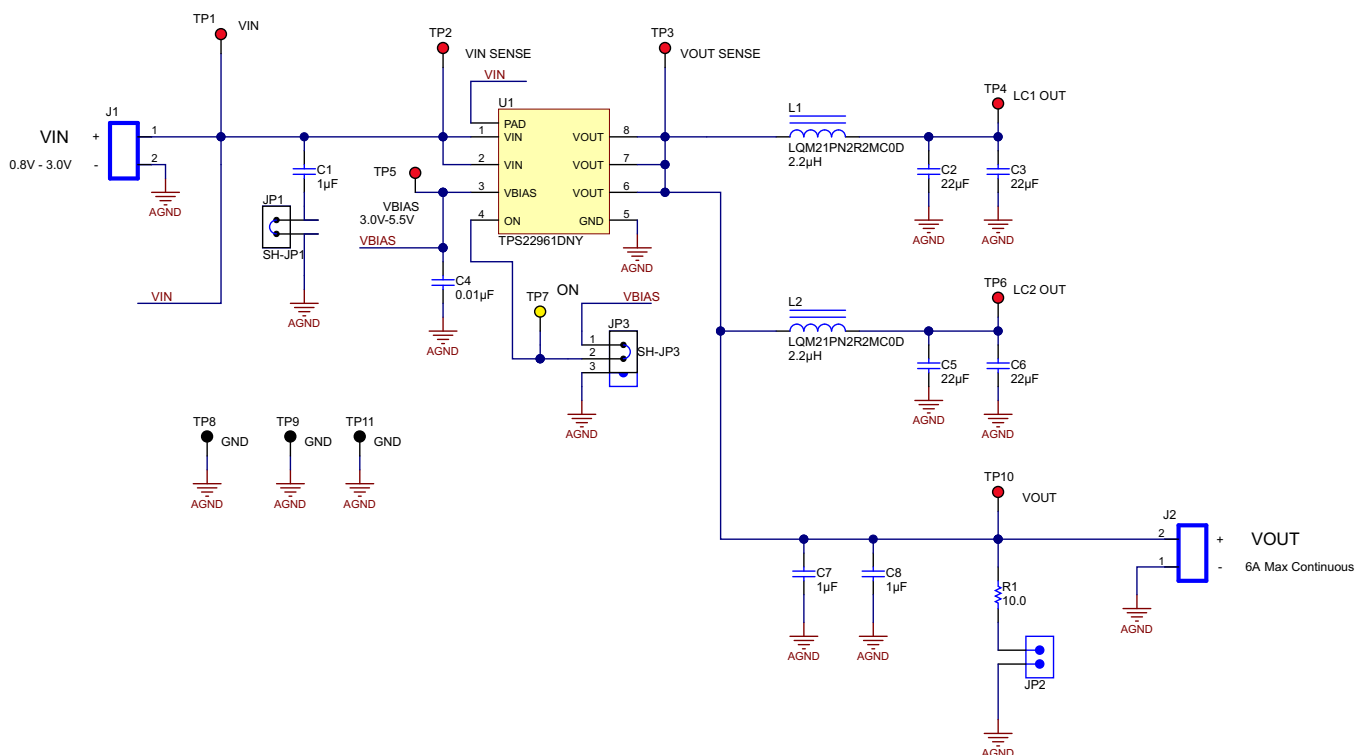

Figure 1. TPS22961EVM-067 Schematic

4 Layouts

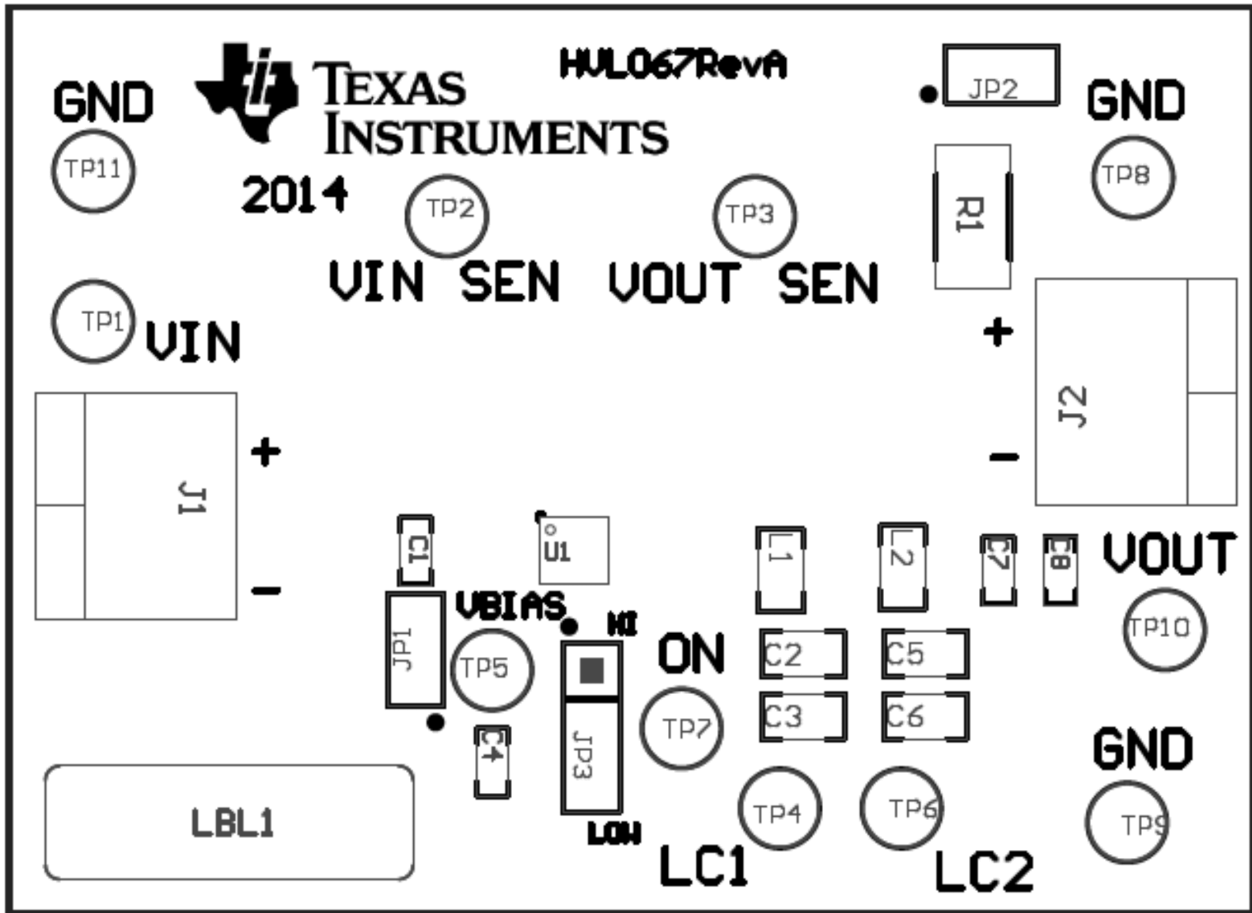

Figure 2. TPS22961EVM-067 Top Assembly

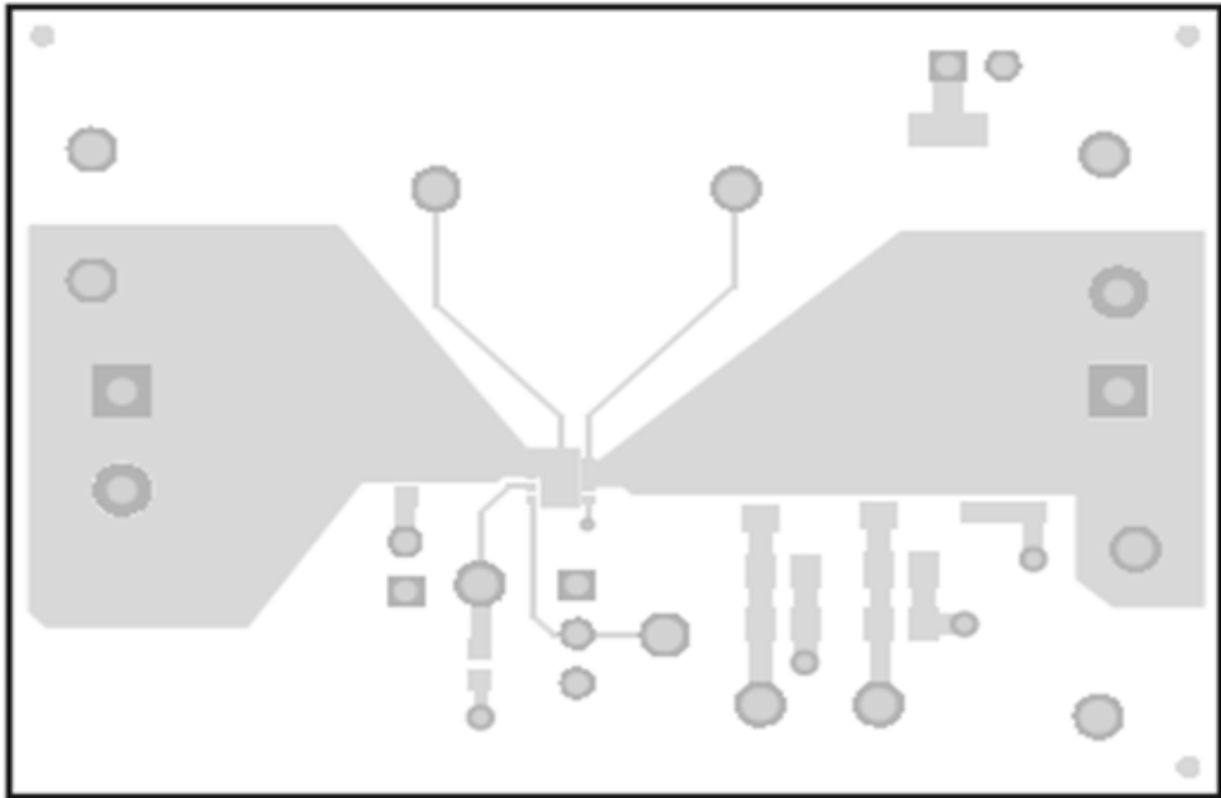

Figure 3. TPS22961EVM-067 Top Layout



Figure 4. TPS22961EVM-067 Bottom Layout

4.1 Setup

This section describes the jumpers and connectors on the EVM as well as how to properly connect, set up, and use the EVM.

4.1.1 J1 – Input Connection

This is the connection for the leads from the input source. Connect the positive lead to J1-1 (+) terminal and the negative lead to J1-2 (–) terminal (GND). TP1 is also available for connecting to the input. J1 Connector is rated for currents of 15A, use the J1 input connection point when operating the EVM in the High current mode ($I_{IN} > 3A$).

4.1.2 J2 – Output Connection

This is the connection for the output of the EVM. Connect the positive lead to J2-2 (+) terminal and the negative lead to J2-1 (–) terminal (GND). TP10 is also available for connecting to the output. J2 Connector is rated for currents of 15A, use the J2 input connection point when operating the EVM in the High current mode ($I_{OUT} > 3A$).

4.1.3 JP3 – ON

This is the enable input for the device. A shorting jumper must be installed on JP3 in either the High or Low Position. The TPS22961 is active High. ON must not be left floating. An external enable source can be applied to the EVM by removing the shunt and connecting a signal to TP7. Refer to the datasheet for proper ON and OFF voltage level settings. A switching signal may also be used and connected at this point.

4.1.4 TP2 –VIN Sense, TP3 - VOUT Sense

These two connections are used when very accurate measurements of the input or output are required. RON measurements should be made using these sense connections when measuring the voltage drop from VIN to VOUT and then calculating the resistance.

4.1.5 JP1 – Input Capacitor

During normal operation a shorting jumper is placed on JP1 this connects C1 capacitor from the input of the device to ground. Refer to the Applications Section of the Datasheet for additional information on selecting the input capacitor..

4.1.6 C7 and C8 – Output Capacitors

During normal operation C7 and C8 capacitors are connected from the output of the device to ground. Refer to the Applications Section of the Datasheet for additional information on selecting the output capacitors.

4.1.7 JP2 – Output Resistor

During normal operation no shorting jumper is placed on JP2. A shorting jumper may be used on JP2 to connect R1 10Ω load resistor from the output of the device to ground. R1 is sized for a 2512 1.5W power resistor.

4.1.8 TP4/TP6– Filtered Outputs

These output connections are low current output that can be used as additional loads for the device.

4.1.9 TP8/TP9/TP11– GND

These are connections to GND.

5 Operation

Connect the positive input of the power supply to VIN at J1-1; connect the negative lead of the power supply to GND at J1-2. The input voltage range of the TPS22961EVM-067 is 0.8V to 3.0V.

External output loads can be applied to the switch by connecting between J2-2 VOUT and J2-1 GND, The TPS22961EVM-067 is rated for a maximum continuous current of 6A. Configure JP3 as required. JP3 must be installed for proper operation. When the ON pin is asserted high, the output of the TPS22961 will be enabled.

6 Test Configuraions

6.1 On-Resistance (R_{ON}) Test Setup

[Figure 5](#) shows a typical setup for measuring On-Resistance. The voltage drop across the switch is measured using the sense connections then divided by the current into the load yielding the R_{ON} resistance.

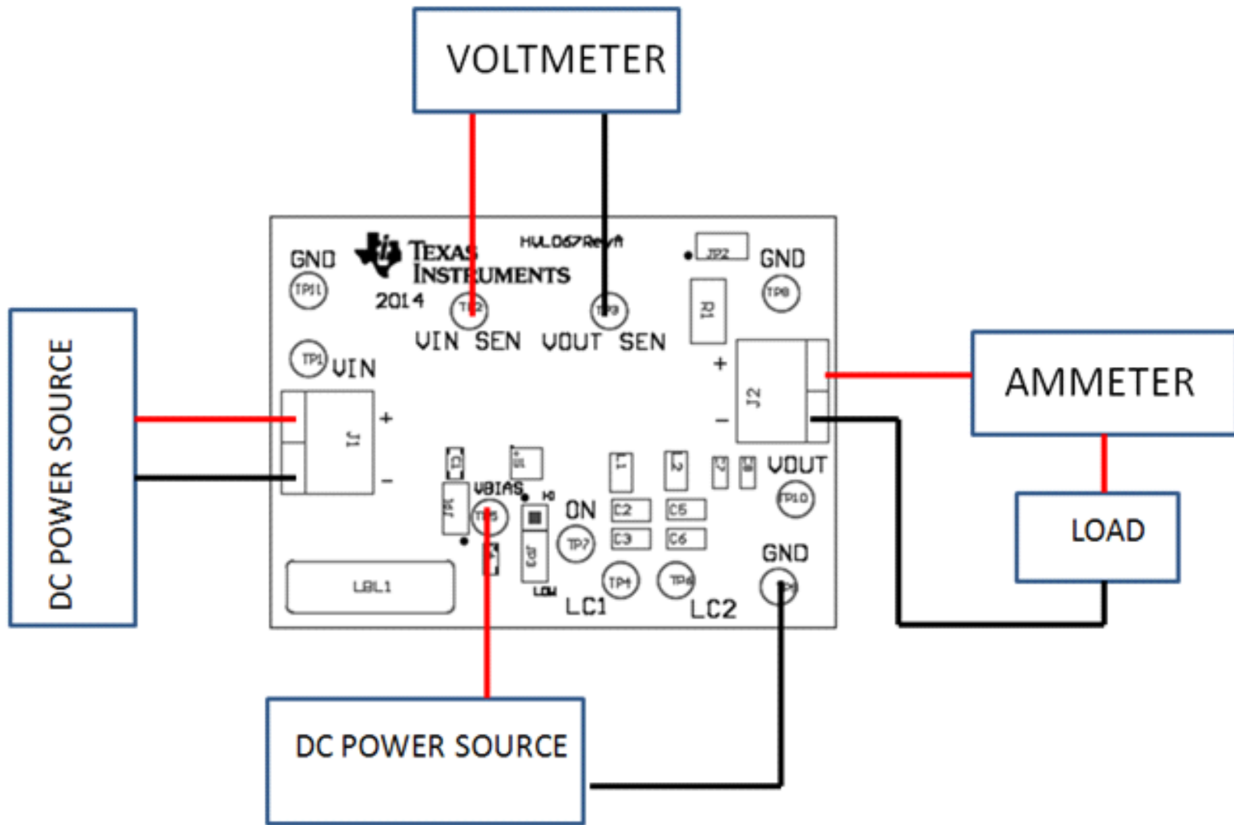

Figure 5. R_{ON} Setup

6.2 Slew Rate Test Setup

Figure 6 shows a test setup for measuring the Slew Rate of the Load Switch. Controlling the ON pin of the switch with a signal source and then measuring the outputs with a scope shows the switches ability to have a controlled VOUT ramp.

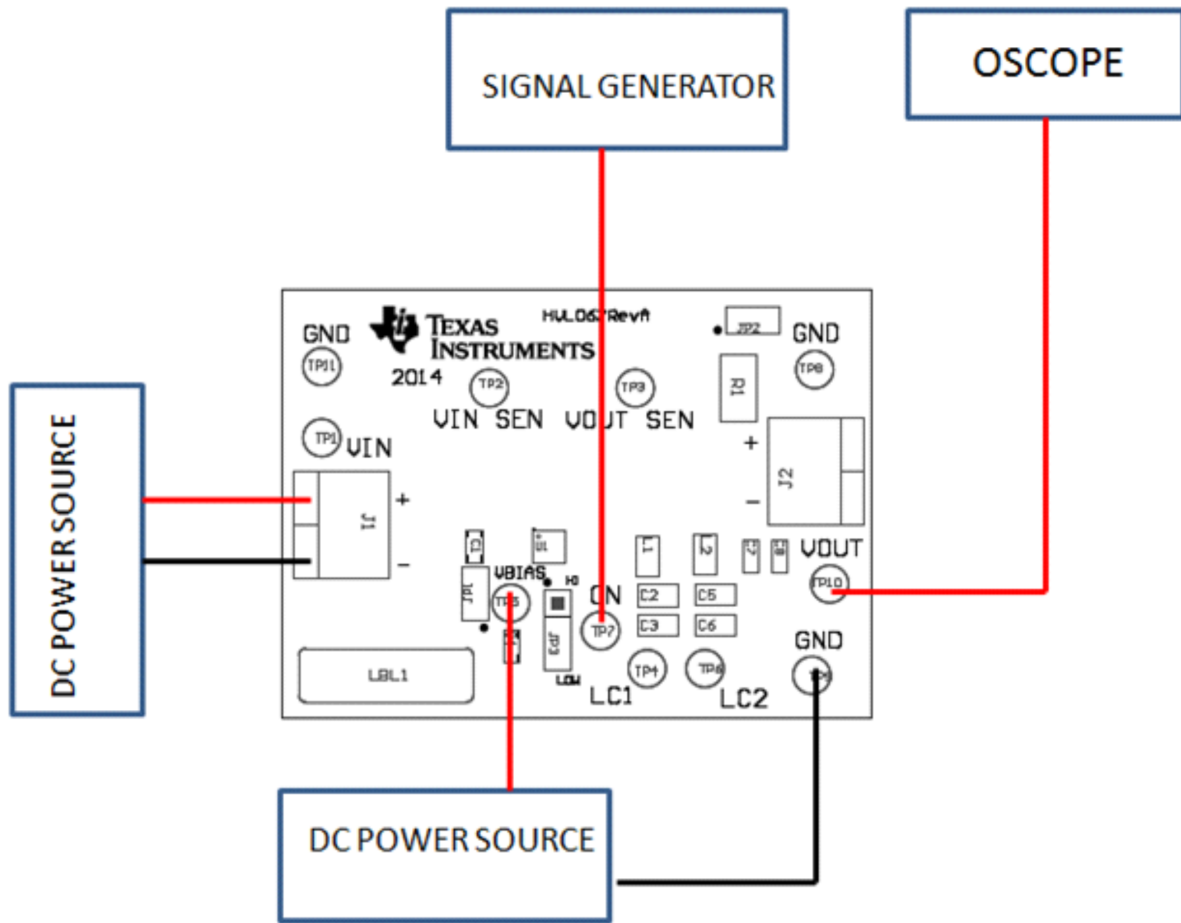

Figure 6. Slew Rate Setup

6.3 VOUT Slew Rate Examples

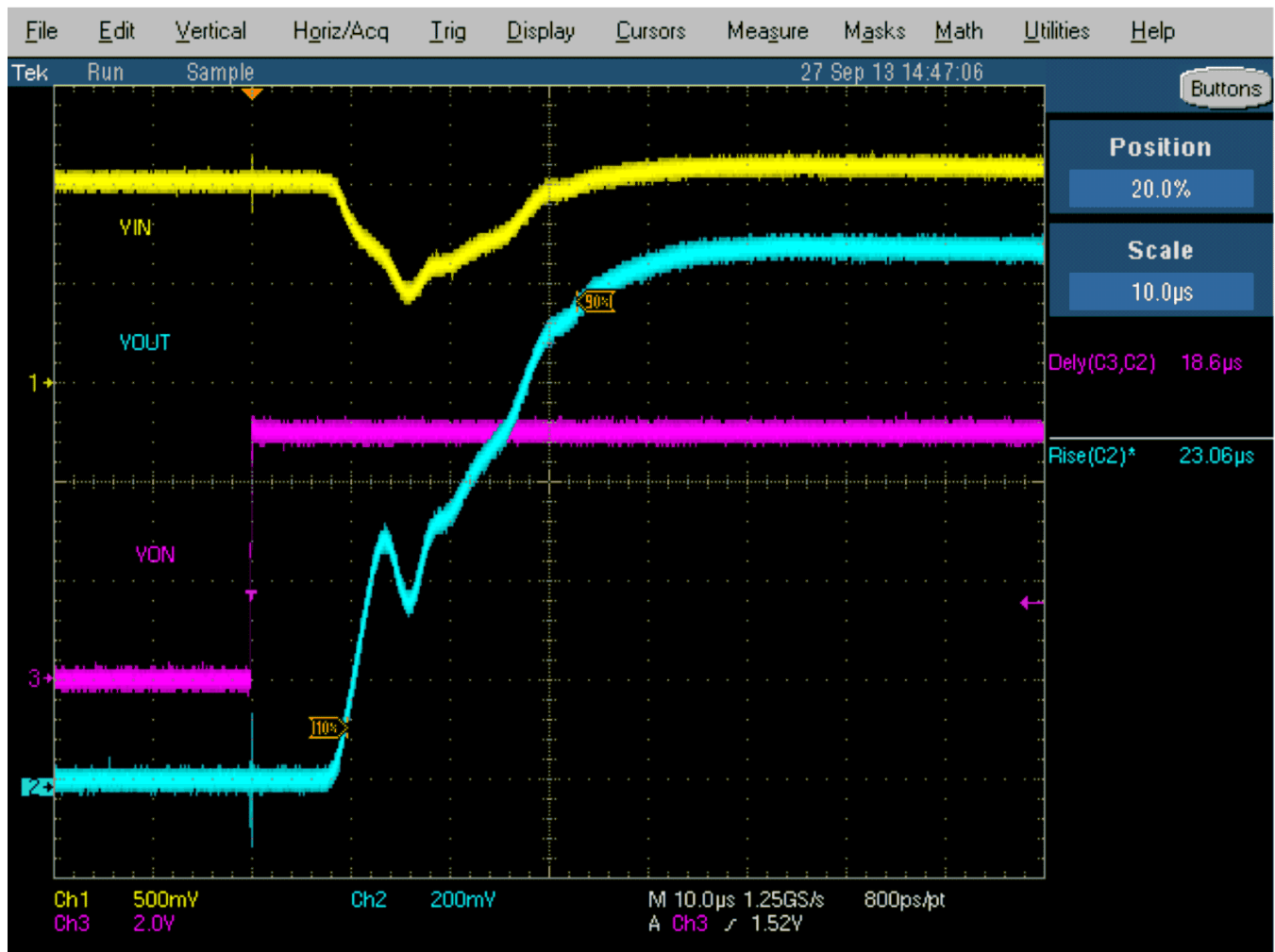

Figure 7. TPS22961 Vout t_R Example

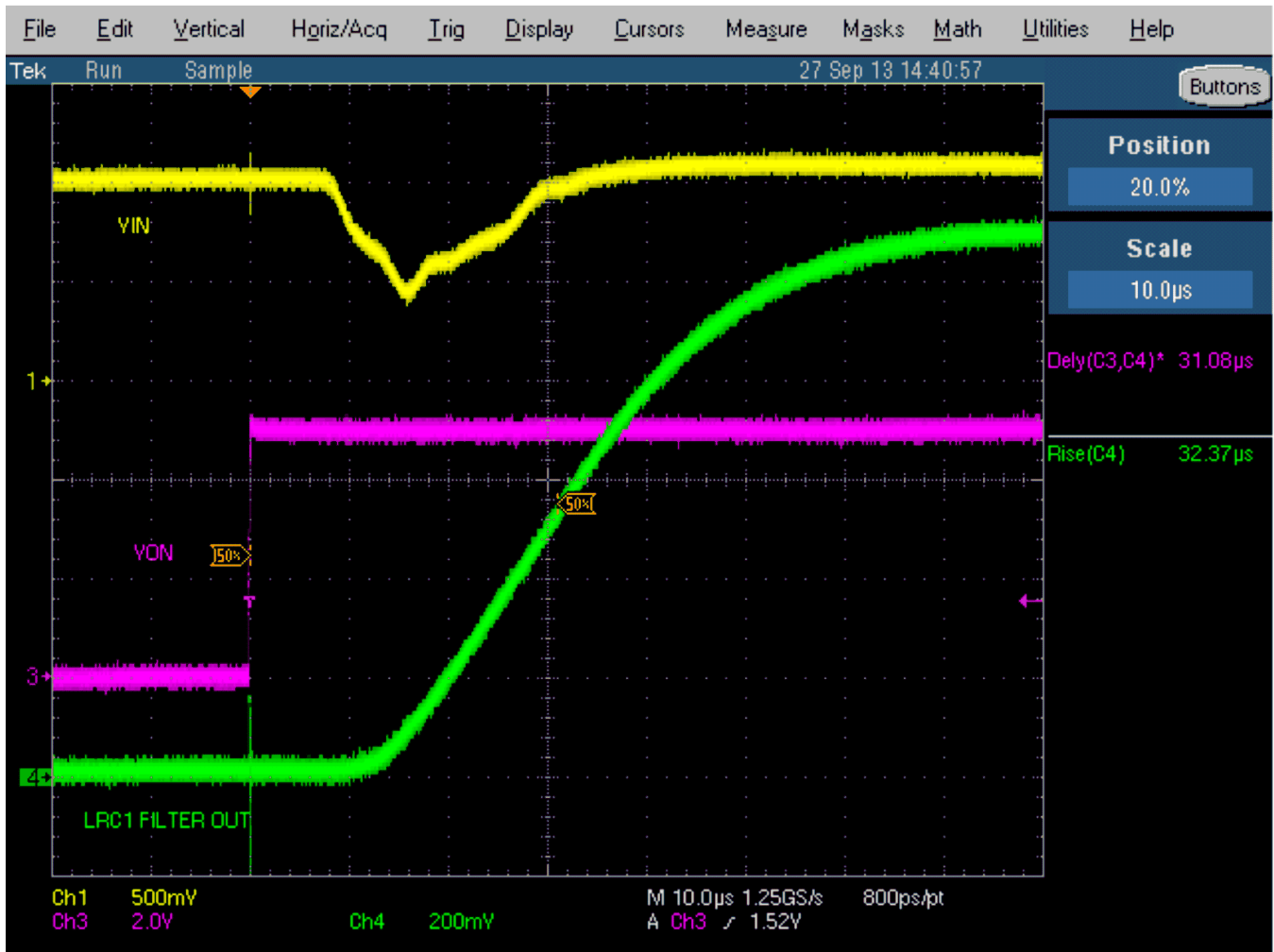

Figure 8. TPS22961 LC1 Filtered t_R Example

7 Bill of Materials (BOM)

Table 2. Bill of Materials⁽¹⁾

Designator	Quantity	Value	Description	Package Reference	Part Number	Manufacturer	Alternate Part Number	Alternate Manufacturer
PCB	1		Printed Circuit Board		HVL067	Any	–	–
C1, C7, C8	3	1 μ F	CAP, CERM, 1 μ F, 16V, \pm 10%, X5R, 0603	0603	C0603C105K4PAC TU	Kemet		
C2, C3, C5, C6	4	22 μ F	CAP, CERM, 22 μ F, 10V, \pm 10%, X5R, 0805	0805	CL21R226KQNN NE	Samsung		
C4	1	0.01 μ F	CAP, CERM, 0.01 μ F, 50V, \pm 5%, X7R, 0603	0603	C0603C103J5RAC TU	Kemet		
FID1, FID2, FID3	3		Fiducial mark. This is nothing to buy or mount	Fiducial	N/A	N/A		
J1, J2	2	ED120/2DS	Terminal Block, 2-pin, 15-A, 5.1mm		ED120/2DS	OST		
JP1, JP2	2		Header, 100mil, 2x1, Tin plated, TH		PEC02SAN	Sullins Connector Solutions		
JP3	1		Header, 100mil, 3x1, Tin plated, TH		PEC0SAAN	Sullins Connector Solutions		
L1, L2	2	2.2 μ H	Inductor, Shielded, Ferrite, 2.2 μ H, 0.8A, 0.23 Ω , SMD	0805	LQM21PN2R2NGC	Murata		
LBL1	1		Thermal Transfer Printable Labels, 0.650" W x 0.200" H -10,000 per roll	PCB Label 0.650"H x 0.200"W	THT-14-423-10	Brady		
R1	1	10.0	RES, 10.0 Ω , 5%, 1.5W, 2512	2512	RPC2512JT10R0	Stackpole Electronics Inc.		
SH-JP1, SH-JP3	2	1x2	Shunt, 100mil, Gold plated, Black	Shunt	969102-0000-DA	3M	SNT-100-BK-G	Samtec
TP1–TP6, TP10	7	Red	Test Point, Multipurpose, Red, TH	Red Multipurpose Testpoint	5010	Keystone		
TP7	1	Yellow	Test Point, Compact, Yellow, TH	Yellow Compact Testpoint	5009	Keystone		
TP8, TP9, TP11	3	Black	Test Point, Multipurpose, Black, TH	Black Multipurpose Testpoint	5011	Keystone		
U1	1		IC, Ultra- Low on Resistance, 6A Single Chan-Load SW with Controlled Turn-On	DNY0008A	TPS22961DNY	Texas Instruments		None

⁽¹⁾ Unless otherwise noted in the Alternative Part Number and/or Alternative Manufacturer columns, all parts may be substituted with equivalents.

IMPORTANT NOTICE

Texas Instruments Incorporated and its subsidiaries (TI) reserve the right to make corrections, enhancements, improvements and other changes to its semiconductor products and services per JESD46, latest issue, and to discontinue any product or service per JESD48, latest issue. Buyers should obtain the latest relevant information before placing orders and should verify that such information is current and complete. All semiconductor products (also referred to herein as "components") are sold subject to TI's terms and conditions of sale supplied at the time of order acknowledgment.

TI warrants performance of its components to the specifications applicable at the time of sale, in accordance with the warranty in TI's terms and conditions of sale of semiconductor products. Testing and other quality control techniques are used to the extent TI deems necessary to support this warranty. Except where mandated by applicable law, testing of all parameters of each component is not necessarily performed.

TI assumes no liability for applications assistance or the design of Buyers' products. Buyers are responsible for their products and applications using TI components. To minimize the risks associated with Buyers' products and applications, Buyers should provide adequate design and operating safeguards.

TI does not warrant or represent that any license, either express or implied, is granted under any patent right, copyright, mask work right, or other intellectual property right relating to any combination, machine, or process in which TI components or services are used. Information published by TI regarding third-party products or services does not constitute a license to use such products or services or a warranty or endorsement thereof. Use of such information may require a license from a third party under the patents or other intellectual property of the third party, or a license from TI under the patents or other intellectual property of TI.

Reproduction of significant portions of TI information in TI data books or data sheets is permissible only if reproduction is without alteration and is accompanied by all associated warranties, conditions, limitations, and notices. TI is not responsible or liable for such altered documentation. Information of third parties may be subject to additional restrictions.

Resale of TI components or services with statements different from or beyond the parameters stated by TI for that component or service voids all express and any implied warranties for the associated TI component or service and is an unfair and deceptive business practice. TI is not responsible or liable for any such statements.

Buyer acknowledges and agrees that it is solely responsible for compliance with all legal, regulatory and safety-related requirements concerning its products, and any use of TI components in its applications, notwithstanding any applications-related information or support that may be provided by TI. Buyer represents and agrees that it has all the necessary expertise to create and implement safeguards which anticipate dangerous consequences of failures, monitor failures and their consequences, lessen the likelihood of failures that might cause harm and take appropriate remedial actions. Buyer will fully indemnify TI and its representatives against any damages arising out of the use of any TI components in safety-critical applications.

In some cases, TI components may be promoted specifically to facilitate safety-related applications. With such components, TI's goal is to help enable customers to design and create their own end-product solutions that meet applicable functional safety standards and requirements. Nonetheless, such components are subject to these terms.

No TI components are authorized for use in FDA Class III (or similar life-critical medical equipment) unless authorized officers of the parties have executed a special agreement specifically governing such use.

Only those TI components which TI has specifically designated as military grade or "enhanced plastic" are designed and intended for use in military/aerospace applications or environments. Buyer acknowledges and agrees that any military or aerospace use of TI components which have **not** been so designated is solely at the Buyer's risk, and that Buyer is solely responsible for compliance with all legal and regulatory requirements in connection with such use.

TI has specifically designated certain components as meeting ISO/TS16949 requirements, mainly for automotive use. In any case of use of non-designated products, TI will not be responsible for any failure to meet ISO/TS16949.

Products

Audio	www.ti.com/audio
Amplifiers	amplifier.ti.com
Data Converters	dataconverter.ti.com
DLP® Products	www.dlp.com
DSP	dsp.ti.com
Clocks and Timers	www.ti.com/clocks
Interface	interface.ti.com
Logic	logic.ti.com
Power Mgmt	power.ti.com
Microcontrollers	microcontroller.ti.com
RFID	www.ti-rfid.com
OMAP Applications Processors	www.ti.com/omap
Wireless Connectivity	www.ti.com/wirelessconnectivity

Applications

Automotive and Transportation	www.ti.com/automotive
Communications and Telecom	www.ti.com/communications
Computers and Peripherals	www.ti.com/computers
Consumer Electronics	www.ti.com/consumer-apps
Energy and Lighting	www.ti.com/energy
Industrial	www.ti.com/industrial
Medical	www.ti.com/medical
Security	www.ti.com/security
Space, Avionics and Defense	www.ti.com/space-avionics-defense
Video and Imaging	www.ti.com/video

TI E2E Community

e2e.ti.com