

TWO-CELL Li-ION CHARGE MANAGEMENT IC FOR PDAs AND INTERNET APPLIANCES

Check for Samples: [bq24004](#), [bq24005](#), [bq24006](#)

FEATURES

- **Highly Integrated Solution With FET Pass Transistor and Reverse-Blocking Schottky and Thermal Protection**
- **Integrated Voltage and Current Regulation With Programmable Charge Current**
- **High-Accuracy Voltage Regulation ($\pm 1\%$)**
- **Ideal for Low-Dropout Linear Charger Designs for Two-Cell Li-Ion Packs With Coke or Graphite Anodes**
- **Up to 1.2-A Continuous Charge Current**
- **Safety-Charge Timer During Preconditioning and Fast Charge**
- **Integrated Cell Conditioning for Reviving Deeply Discharged Cells and Minimizing Heat Dissipation During Initial Stage of Charge**
- **Optional Temperature or Input-Power Monitoring Before and During Charge**
- **Various Charge-Status Output Options for Driving Single, Double, or Bicolor LEDs or Host-Processor Interface**
- **Charge Termination by Minimum Current and Time**
- **Low-Power Sleep Mode**
- **Packaging: 20-Lead TSSOP PowerPAD™**

APPLICATIONS

- PDAs
- Internet Appliances
- MP3 Players
- Digital Cameras

DESCRIPTION

The bq2400x series ICs are advanced Li-Ion linear charge management devices for highly integrated and space-limited applications. They combine high-accuracy current and voltage regulation; FET pass-transistor and reverse-blocking Schottky; battery conditioning, temperature, or input-power monitoring; charge termination; charge-status indication; and charge timer in a small package.

The bq2400x measures battery temperature using an external thermistor. For safety, the bq2400x inhibits charge until the battery temperature is within the user-defined thresholds. Alternatively, the user can monitor the input voltage to qualify charge. The bq2400x series then charge the battery in three phases: preconditioning, constant current, and constant voltage. If the battery voltage is below the internal low-voltage threshold, the bq2400x uses low-current precharge to condition the battery. A preconditioning timer provides additional safety. Following pre-conditioning, the bq2400x applies a constant-charge current to the battery. An external sense-resistor sets the magnitude of the current. The constant-current phase is maintained until the battery reaches the charge-regulation voltage. The bq2400x then transitions to the constant voltage phase. The user can configure the device for cells with either coke or graphite anodes. The accuracy of the voltage regulation is better than $\pm 1\%$ over the operating junction temperature and supply voltage range.

Charge is terminated by maximum time or minimum taper current detection

The bq2400x automatically restarts the charge if the battery voltage falls below an internal recharge threshold.



Please be aware that an important notice concerning availability, standard warranty, and use in critical applications of Texas Instruments semiconductor products and disclaimers thereto appears at the end of this data sheet.

PowerPAD is a trademark of Texas Instruments.



These devices have limited built-in ESD protection. The leads should be shorted together or the device placed in conductive foam during storage or handling to prevent electrostatic damage to the MOS gates.

ORDERING INFORMATION

T _J	PACKAGE	CHARGE STATUS CONFIGURATION
	20-LEAD HTTSOP PowerPAD™ (PWP) ^{(1) (2)}	
–40°C to 125°C	bq24004PWP	Single LED
	bq24005PWP	2 LEDs
	bq24006PWP	Single bicolor LED

- (1) The PWP package is available taped and reeled. Add R suffix to device type (e.g., bq24005PWPR) to order. Quantities 2500 devices per reel.
- (2) For the most current package and ordering information, see the Package Option Addendum at the end of this document, or see the TI Web site at www.ti.com.

PACKAGE DISSIPATION RATINGS

PACKAGE	Θ _{JA}	Θ _{JC}	T _A ≤ 25°C POWER RATING	DERATING FACTOR ABOVE T _A = 25°C
PWP ⁽¹⁾	30.88°C/W	1.19°C/W	3.238 W	0.0324 W/°C

- (1) This data is based on using the JEDEC high-K board and topside traces, top and bottom thermal pad (6,5 × 3,4 mm), internal 1-oz. power and ground planes, 8 thermal via underneath the die connecting to ground plane.

ABSOLUTE MAXIMUM RATINGS

over operating free-air temperature range unless otherwise noted⁽¹⁾

	bq24004 bq24005 bq24006
Supply voltage (V _{CC} with respect to GND)	13.5 V
Input voltage (IN, ISNS, EN, APG/THERM/CR/STAT1/STAT2, VSENSE, TMR SEL, VSEL) (all with respect to GND)	13.5 V
Output current (OUT pins)	2 A
Output sink/source current (STAT1 and STAT2)	10 mA
T _A Operating free-air temperature range	–40°C to 70°C
T _{stg} Storage temperature range	–65°C to 150°C
T _J Junction temperature range	–40°C to 125°C
Lead temperature (Soldering, 10 s)	300°C

- (1) Stresses beyond those listed under *absolute maximum ratings* may cause permanent damage to the device. These are stress ratings only, and functional operation of the device at these or any other conditions beyond those indicated under *recommended operating conditions* is not implied. Exposure to absolute-maximum-rated conditions for extended periods may affect device reliability.

RECOMMENDED OPERATING CONDITIONS

	MIN	MAX	UNIT
V _{CC} Supply voltage	8.4	10	V
V _{IN} Input voltage	8.4	10	V
Continuous output current		1.2	A
T _J Operating junction temperature range	–40	125	°C

ELECTRICAL CHARACTERISTICS

over recommended operating junction temperature supply and input voltages, and $V_I (V_{CC}) \geq V_I (IN)$ (unless otherwise noted)

PARAMETER	TEST CONDITIONS	MIN	TYP	MAX	UNIT
V_{CC} current	$V_{CC} > V_{CC_UVLO}$, $EN \leq V_{(IEN)}$			1	mA
V_{CC} current, standby mode	$EN \leq V_{(IEN)}$		1		μ A
IN current, standby mode	$EN \leq V_{(IEN)}$			10	μ A
Standby current (sum of currents into OUT and VSENSE pins)	$V_{CC} < V_{CC_UVLO}$, $V_{O(OUT)} = 8.6$ V, $V_{SENSE} = 8.6$ V		2	8	μ A
	$EN \leq V_{(IEN)}$, $V_{O(OUT)} = 8.6$ V, $V_{SENSE} = 8.6$ V		2	8	
VOLTAGE REGULATION, $0^\circ\text{C} \leq T_J \leq 125^\circ\text{C}$					
Output voltage	$V_{SEL} = V_{SS}$, $0 < I_O \leq 1.2$ A	8.118	8.20	8.282	V
	$V_{SEL} = V_{CC}$, $0 < I_O \leq 1.2$ A	8.316	8.40	8.484	
Load regulation	$1 \text{ mA} \leq I_O \leq 1.2 \text{ A}$, $V_{CC} = 10$ V, $V_{I(IN)} = 5$ V, $T_J = 25^\circ\text{C}$		1		mV
Line regulation	$V_{O(OUT)} + V_{DO} + V_{(IIM)} \text{ MAX} < V_{I(VCC)} < 10$ V, $T_J = 25^\circ\text{C}$		0.01		%/V
Dropout voltage = $V_I(IN) - V_{out}$	$I_O = 1.2$ A, $V_{O(OUT)} + V_{(DO)} + V_{(IIM)} \text{ MAX} < V_{I(VCC)} < 10$ V			0.5	V
CURRENT REGULATION, $0^\circ\text{C} \leq T_J \leq 125^\circ\text{C}$					
Current regulation threshold, $V_{I(limit)}$	$V_{SENSE} < V_{O(VSEL_LOW/HIGH)}$	0.093	0.1	0.107	V
Delay time	V_{SENSE} pulsed above $V_{(LOWV)}$ to $I_O = 10\%$ of regulated value ⁽¹⁾			1	ms
Rise time	I_O increasing from 10% to 90% of regulated value, $R_{(SNS)} \geq 0.2 \Omega$ ⁽¹⁾	0.1		1	ms
CURRENT SENSE RESISTOR, $0^\circ\text{C} \leq T_J \leq 125^\circ\text{C}$					
External current sense resistor range $R_{(SNS)}$	$100 \text{ mA} \leq (I_{lim}) \leq 1.2$ A	0.083		1	Ω
PRECHARGE CURRENT REGULATION, $0^\circ\text{C} \leq T_J \leq 125^\circ\text{C}$					
Precharge current regulation	$V_{SENSE} < V_{(LOWV)}$, $0.083 \leq R_{(SNS)} \leq 1.0 \Omega$	40	60	80	mA
V_{CC} UVLO COMPARATOR, $0^\circ\text{C} \leq T_J \leq 125^\circ\text{C}$					
Start threshold		8.75	8.9	9.0	V
Stop threshold		8.50	8.66	8.8	V
Hysteresis		50			mV
APG/THERM COMPARATOR, $0^\circ\text{C} \leq T_J \leq 125^\circ\text{C}$					
Upper trip threshold		1.480	1.498	1.515	V
Lower trip threshold		0.545	0.558	0.570	V
Input bias current				1	μ A
LOWV COMPARATOR, $0^\circ\text{C} \leq T_J \leq 125^\circ\text{C}$					
Start threshold		5.60	5.75	5.90	V
Stop threshold		6.10	6.25	6.40	V
Hysteresis		100			mV
HIGHV (RECHARGE) COMPARATOR, $0^\circ\text{C} \leq T_J \leq 125^\circ\text{C}$					
Start threshold		7.70	7.85	8.00	V
OVERV COMPARATOR, $0^\circ\text{C} \leq T_J \leq 125^\circ\text{C}$					
Start threshold		8.85	9.00	9.15	V
Stop threshold		8.45	8.60	8.75	V
Hysteresis		50			mV
TAPERDET COMPARATOR, $0^\circ\text{C} \leq T_J \leq 125^\circ\text{C}$					
Trip threshold		12	18.5	25	mV
EN LOGIC INPUT, $0^\circ\text{C} \leq T_J \leq 125^\circ\text{C}$					
High-level input voltage		2.25			V
Low-level input voltage				0.8	V
Input pulldown resistance		100		200	k Ω

(1) Specified by design, not production tested.

ELECTRICAL CHARACTERISTICS (continued)

over recommended operating junction temperature supply and input voltages, and $V_I (V_{CC}) \geq V_I (IN)$ (unless otherwise noted)

PARAMETER	TEST CONDITIONS	MIN	TYP	MAX	UNIT
VSEL LOGIC INPUT, $0^{\circ}\text{C} \leq T_J \leq 125^{\circ}\text{C}$					
High-level input voltage		2.25			V
Low-level input voltage				0.8	V
Input pulldown resistance		100		200	k Ω
TMR SEL INPUT $0^{\circ}\text{C} \leq T_J \leq 125^{\circ}\text{C}$					
High-level input voltage		2.7			V
Low-level input voltage				0.6	V
Input bias current	$V_{I(\text{TMR SEL})} \leq 5\text{ V}$			15	μA
STAT1, STAT2 (bq24004, bq24006), $0^{\circ}\text{C} \leq T_J \leq 125^{\circ}\text{C}$					
Output (low) saturation voltage	$I_O = 10\text{ mA}$			1.5	V
	$I_O = 4\text{ mA}$			0.6	
Output (high) saturation voltage	$I_O = -10\text{ mA}$	$V_{CC}-1.5$			V
	$I_O = -4\text{ mA}$	$V_{CC}-0.5$			
Output turn on/off time	$I_O = \pm 10\text{ mA}$, $C = 100\text{ pF}^{(2)}$			100	μs
POWER-ON RESET (POR), $0^{\circ}\text{C} \leq T_J \leq 125^{\circ}\text{C}$					
POR delay	See ⁽²⁾	1.2		3	ms
POR falling-edge deglitch	See ⁽²⁾	25		75	μs
APG/THERM DELAY, $0^{\circ}\text{C} \leq T_J \leq 125^{\circ}\text{C}$					
APG/THERM falling-edge deglitch	See ⁽²⁾	25		75	μs
TIMERS, $0^{\circ}\text{C} \leq T_J \leq 125^{\circ}\text{C}$					
User-selectable timer accuracy	$T_A = 25^{\circ}\text{C}$	15%		15%	
		20%		20%	
Precharge and taper timer			22.5		minute
THERMAL SHUTDOWN, $0^{\circ}\text{C} \leq T_J \leq 125^{\circ}\text{C}$					
Thermal trip	See ⁽²⁾		165		$^{\circ}\text{C}$
Thermal hysteresis	See ⁽²⁾		10		$^{\circ}\text{C}$
CR PIN, $0^{\circ}\text{C} \leq T_J \leq 125^{\circ}\text{C}$					
Output voltage	$0 < I_{O(\text{CR})} < 100\text{ }\mu\text{A}$	2.816	2.85	2.88	V

(2) Specified by design, not production tested.

PIN ASSIGNMENTS

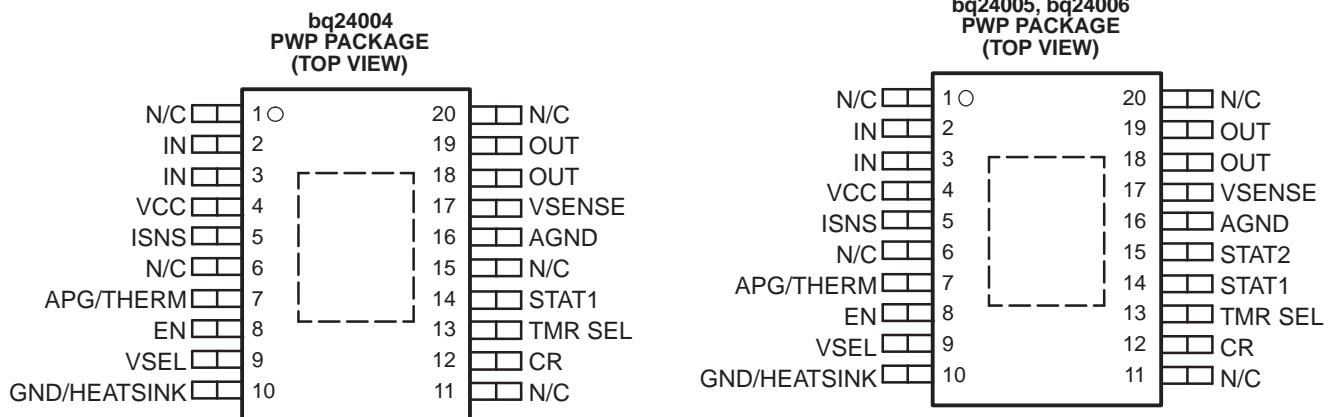

N/C - Do not connect

TERMINAL FUNCTIONS

TERMINAL		I/O	DESCRIPTION
NAME	NO.		
AGND	16		Ground pin; connect close to the negative battery terminal.
APG/THERM	7	I	Adapter power good input/thermistor sense input
CR	12	I	Internal regulator bypass capacitor
EN	8	I	Charge-enable input. Active-high enable input with internal pull down. Low-current stand-by mode active when EN is low.
GND/HEATSINK	10		Ground pin; connect to PowerPAD heat-sink layout pattern.
IN	2, 3	I	Input voltage. This input provides the charging voltage for the battery.
ISNS	5	I	Current sense input
N/C	1, 6, 11, 15, 20		No connect. These pins must be left floating. Pin 15 is N/C on bq24004PWP only.
OUT	18, 19	O	Charge current output
STAT1	14	O	Status display output 1
STAT2	15	O	Status display output 2 (for bq24005 and bq24006 only)
TMR SEL	13	I	Charge timer selection input
VCC	4	I	Supply voltage
VSEL	9	I	8.2-V or 8.4-V charge regulation selection input
VSENSE	17	I	Battery voltage sense input

FUNCTIONAL BLOCK DIAGRAM

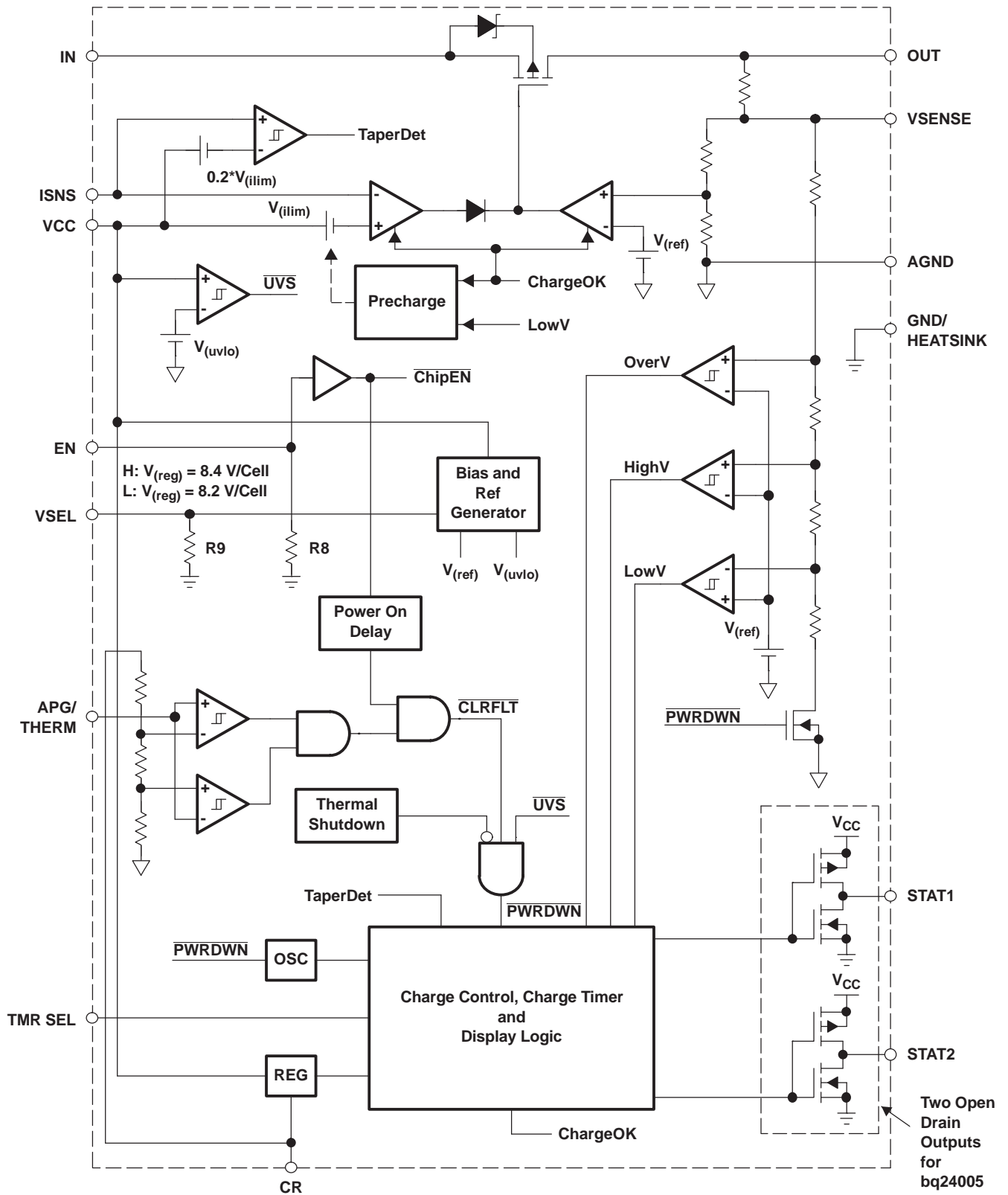

TYPICAL CHARACTERISTICS

OUTPUT VOLTAGE
vs
OUTPUT CURRENT

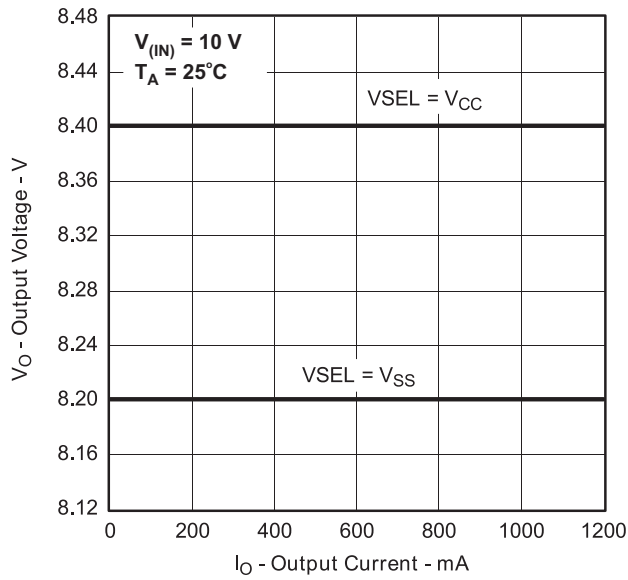

Figure 1.

OUTPUT VOLTAGE
vs
JUNCTION TEMPERATURE

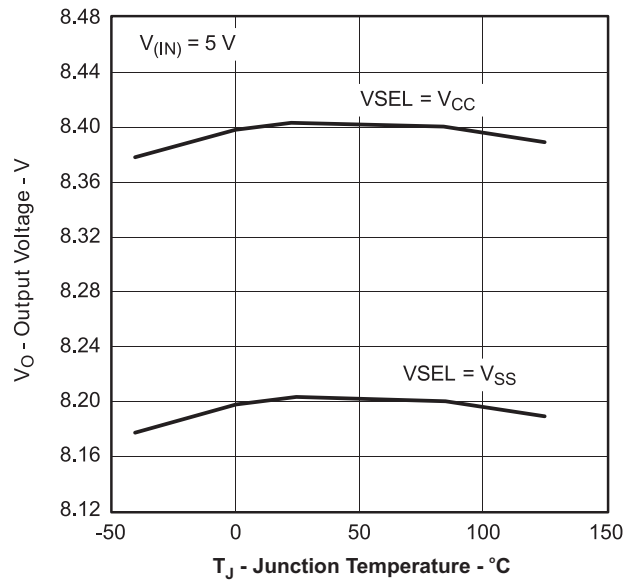

Figure 2.

OUTPUT VOLTAGE
vs
INPUT VOLTAGE

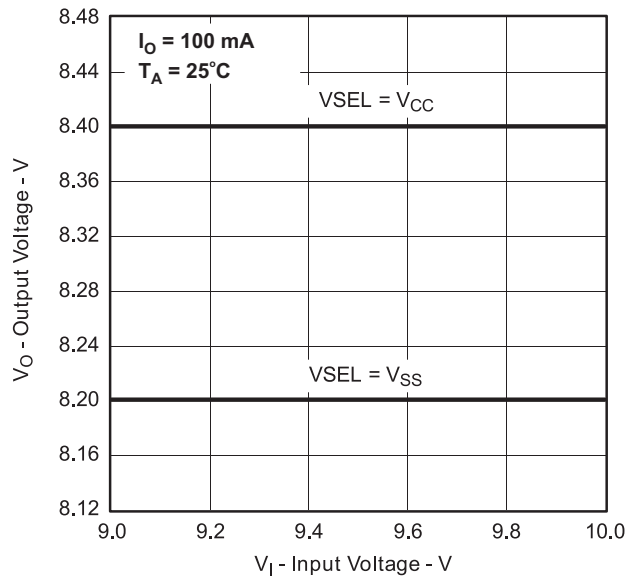

Figure 3.

CURRENT SENSE VOLTAGE
vs
INPUT VOLTAGE

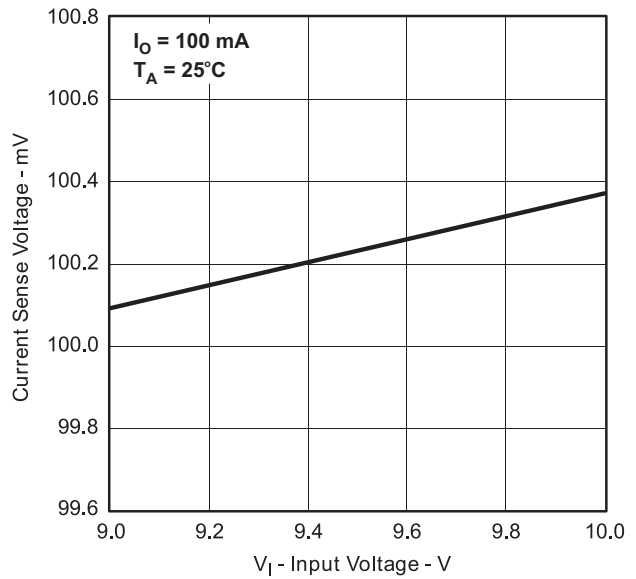

Figure 4.

TYPICAL CHARACTERISTICS (continued)

**CURRENT SENSE VOLTAGE
vs
JUNCTION TEMPERATURE**

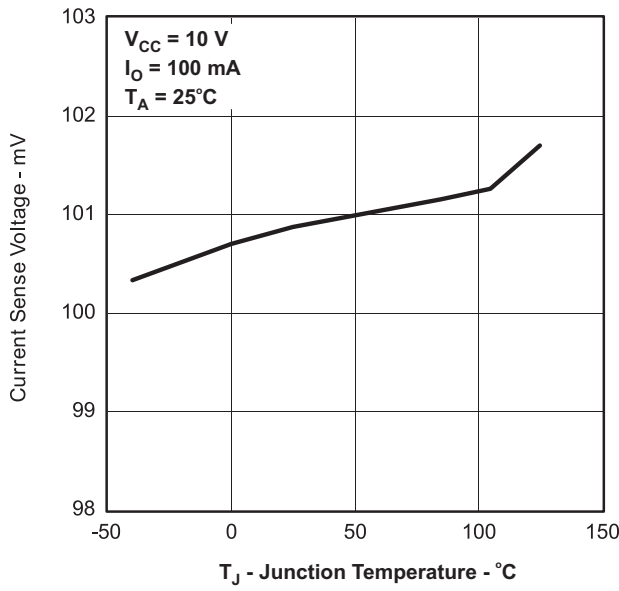

Figure 5.

**QUIESCENT CURRENT
vs
INPUT VOLTAGE**

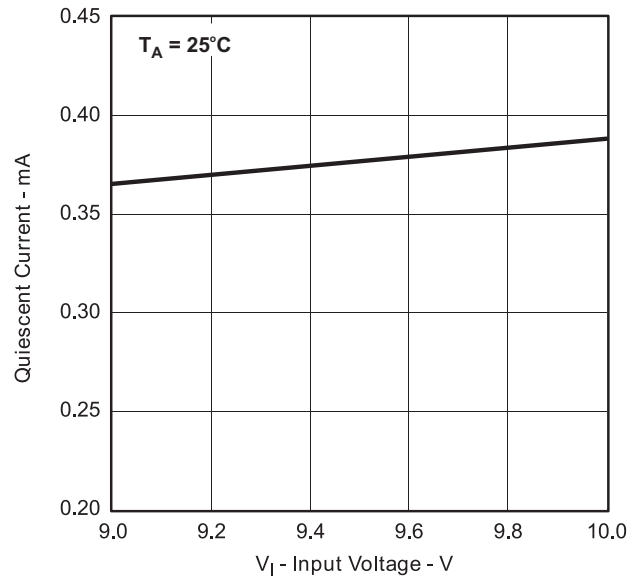

Figure 6.

**QUIESCENT CURRENT (POWER DOWN)
vs
INPUT VOLTAGE**

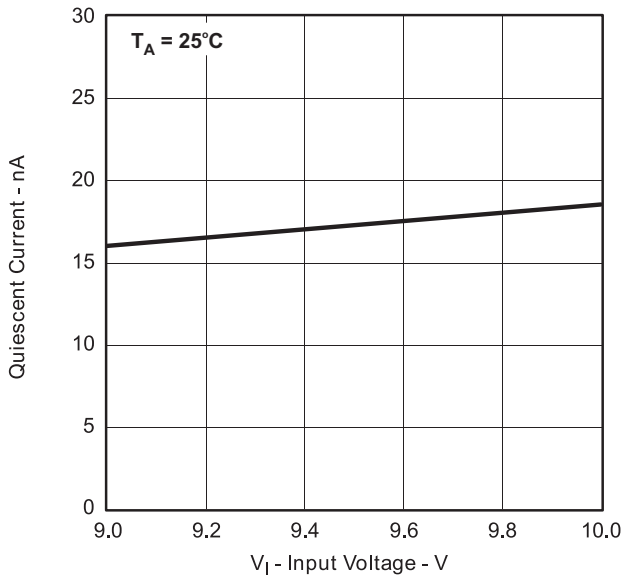

Figure 7.

**DROPOUT VOLTAGE
vs
INPUT VOLTAGE**

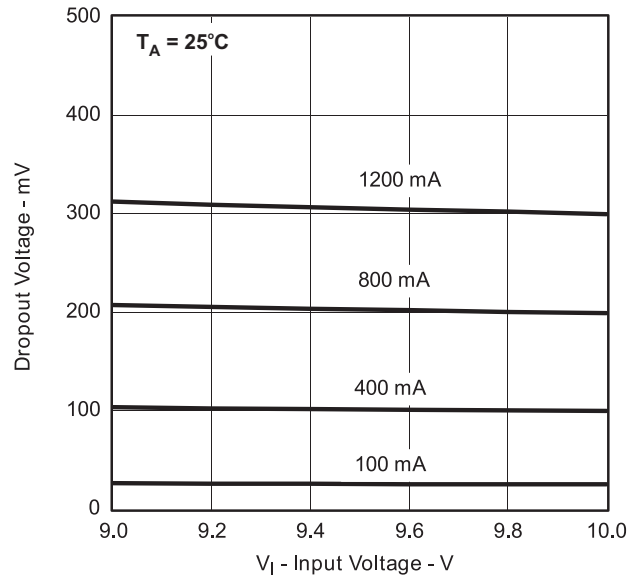

Figure 8.

TYPICAL CHARACTERISTICS (continued)

DROPOUT VOLTAGE
vs
OUTPUT CURRENT

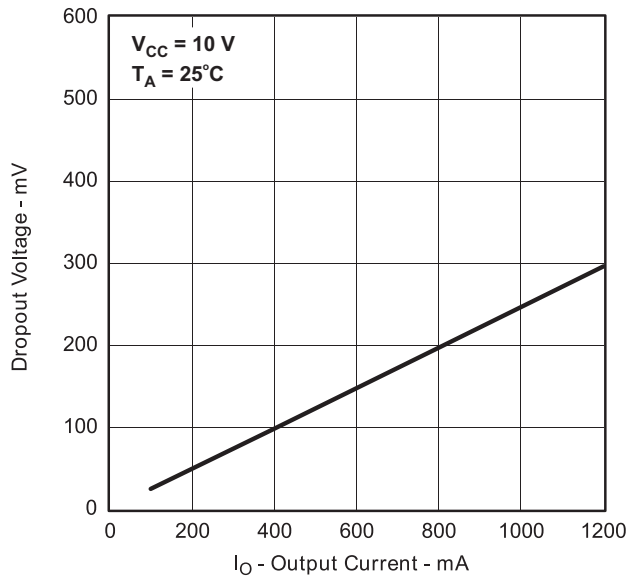

Figure 9.

DROPOUT VOLTAGE
vs
JUNCTION TEMPERATURE

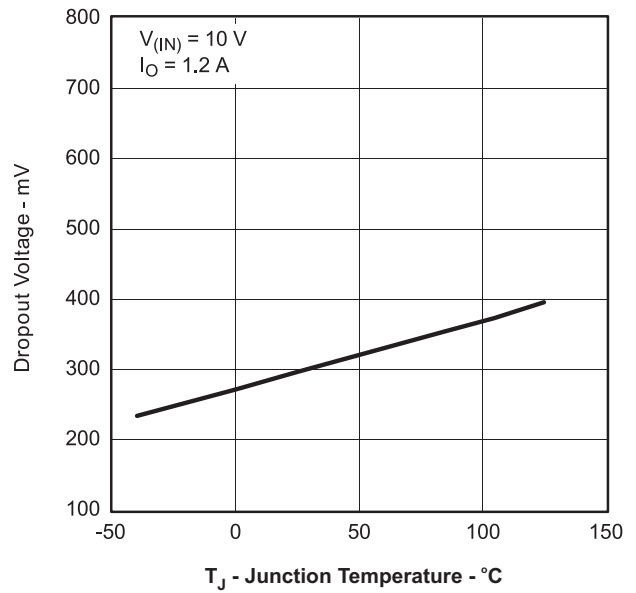

Figure 10.

REVERSE CURRENT
vs
JUNCTION TEMPERATURE

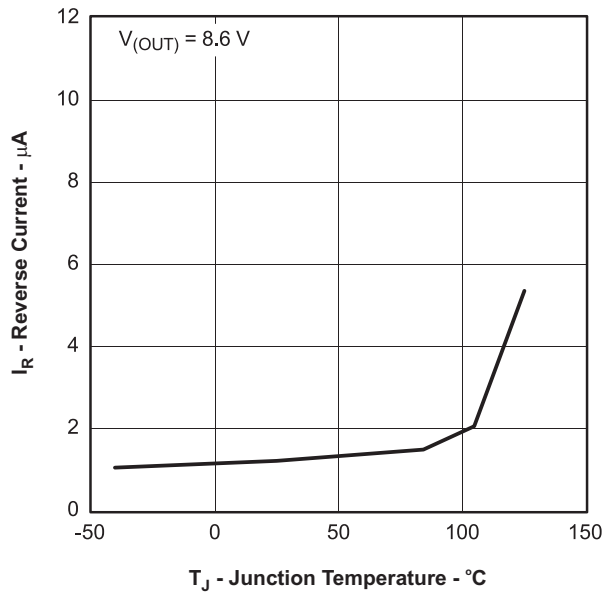

Figure 11.

REVERSE CURRENT LEAKAGE
vs
VOLTAGE ON OUT PIN

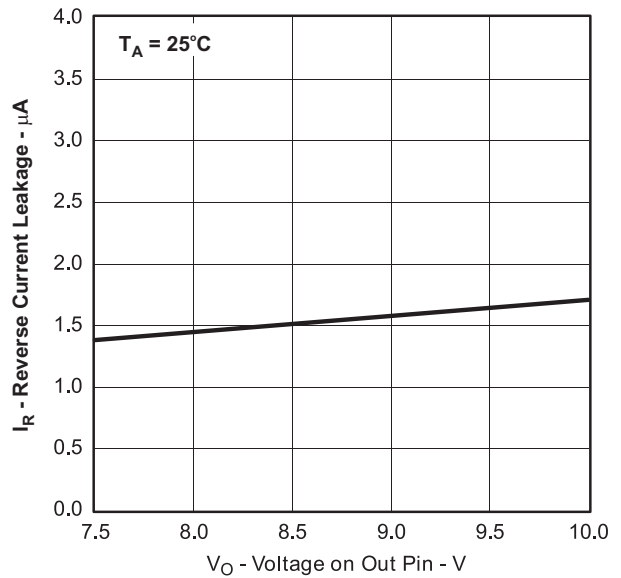

Figure 12.

APPLICATION INFORMATION

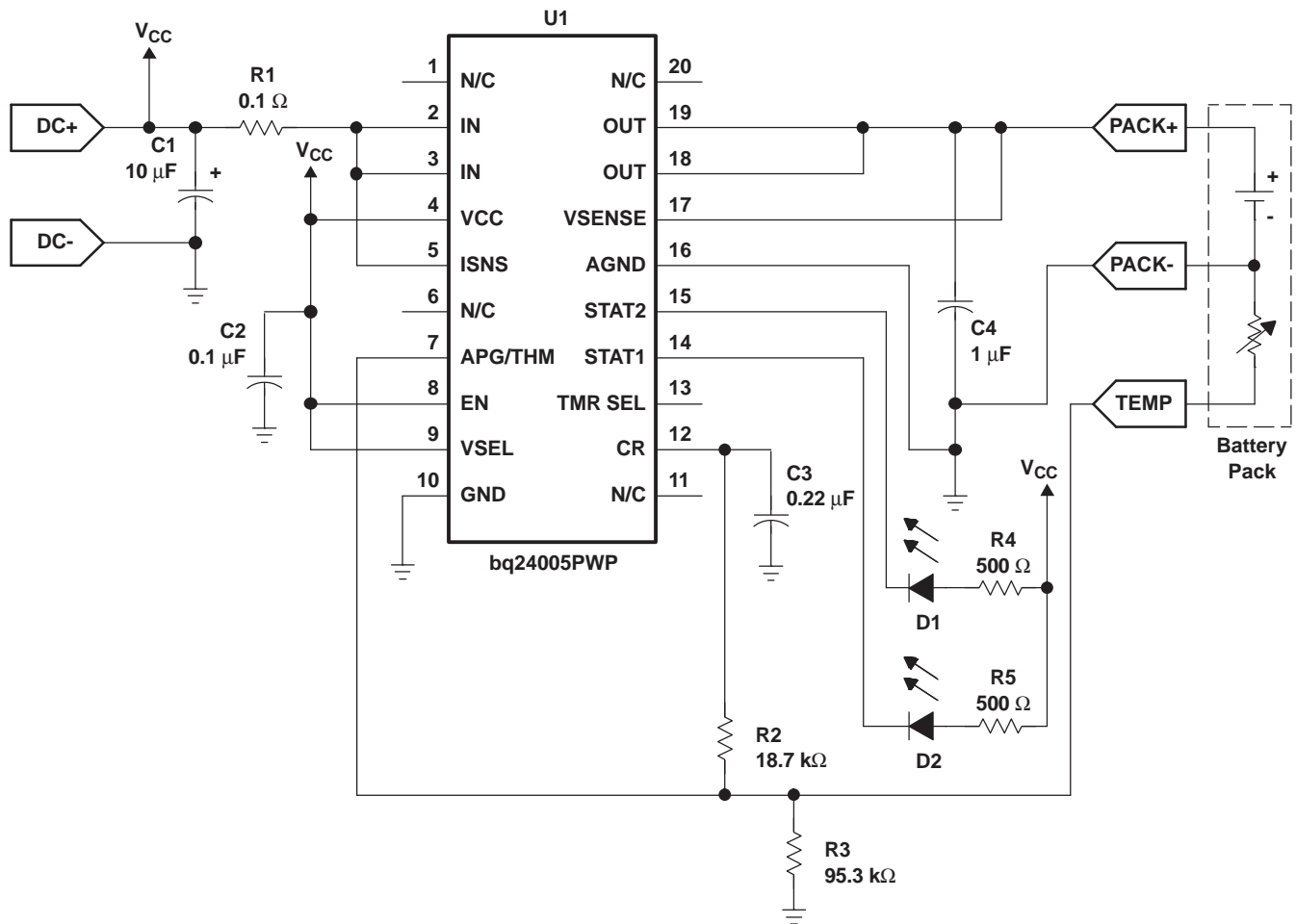

Figure 13. Li-ION/Li-POL Charger

- If the TMR SEL pin is left floating (3 HR time), a 10-pF capacitor should be installed between TMR SEL and CR.
- If a micro process is monitoring the STAT pins, it may be necessary to add some hysteresis into the feedback to prevent the STAT pins from cycling while crossing the taper detect threshold (usually less than one half second). See SLUU083 EVM or SLUU113 EVM for additional resistors used for the STAT pins.

FUNCTIONAL DESCRIPTION

The bq2400x supports a precision current- and voltage-regulated Li-Ion charging system suitable for cells with either coke or graphite anodes. See [Figure 14](#) for a typical charge profile and [Figure 15](#) for an operational flowchart.

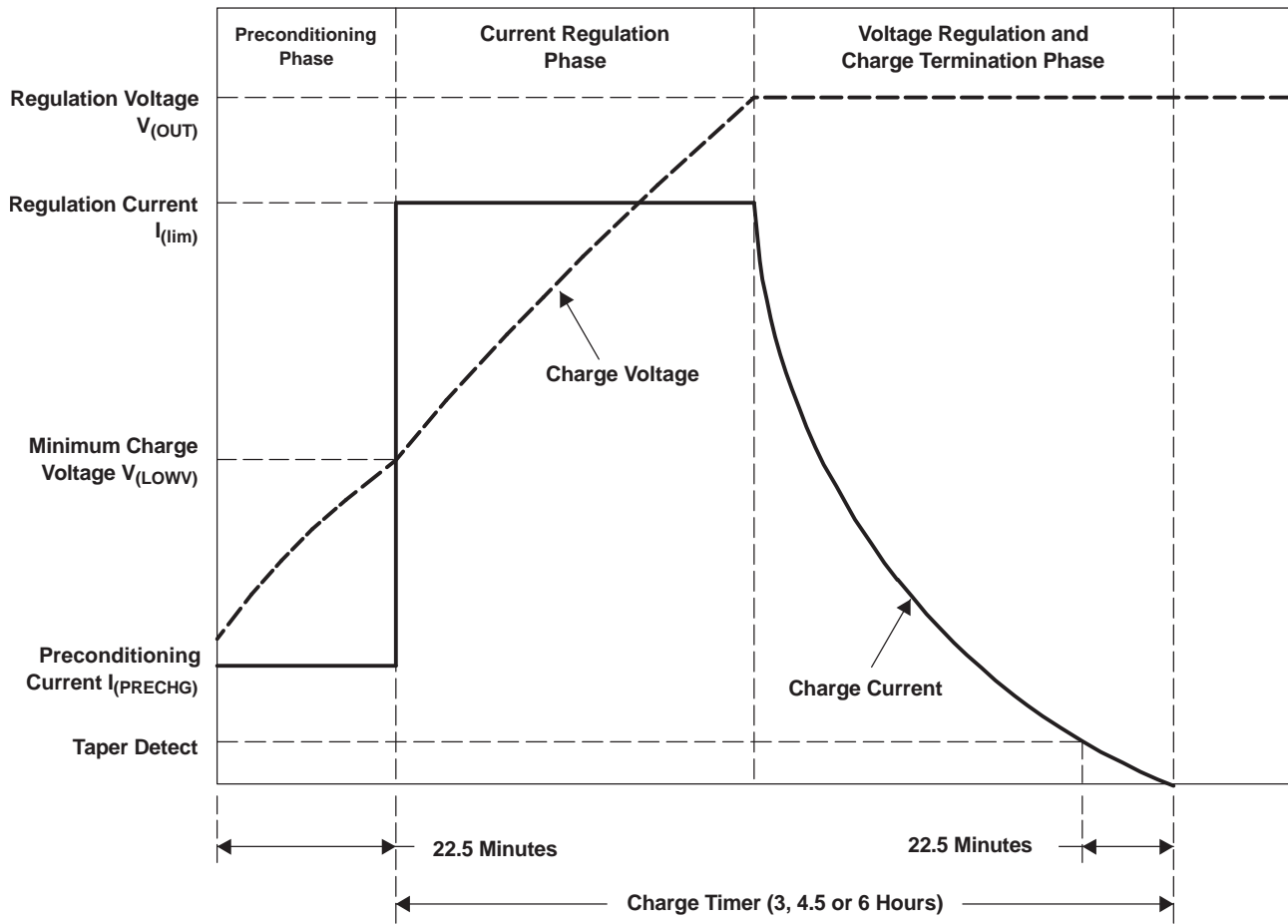

Figure 14. Typical Charge Profile

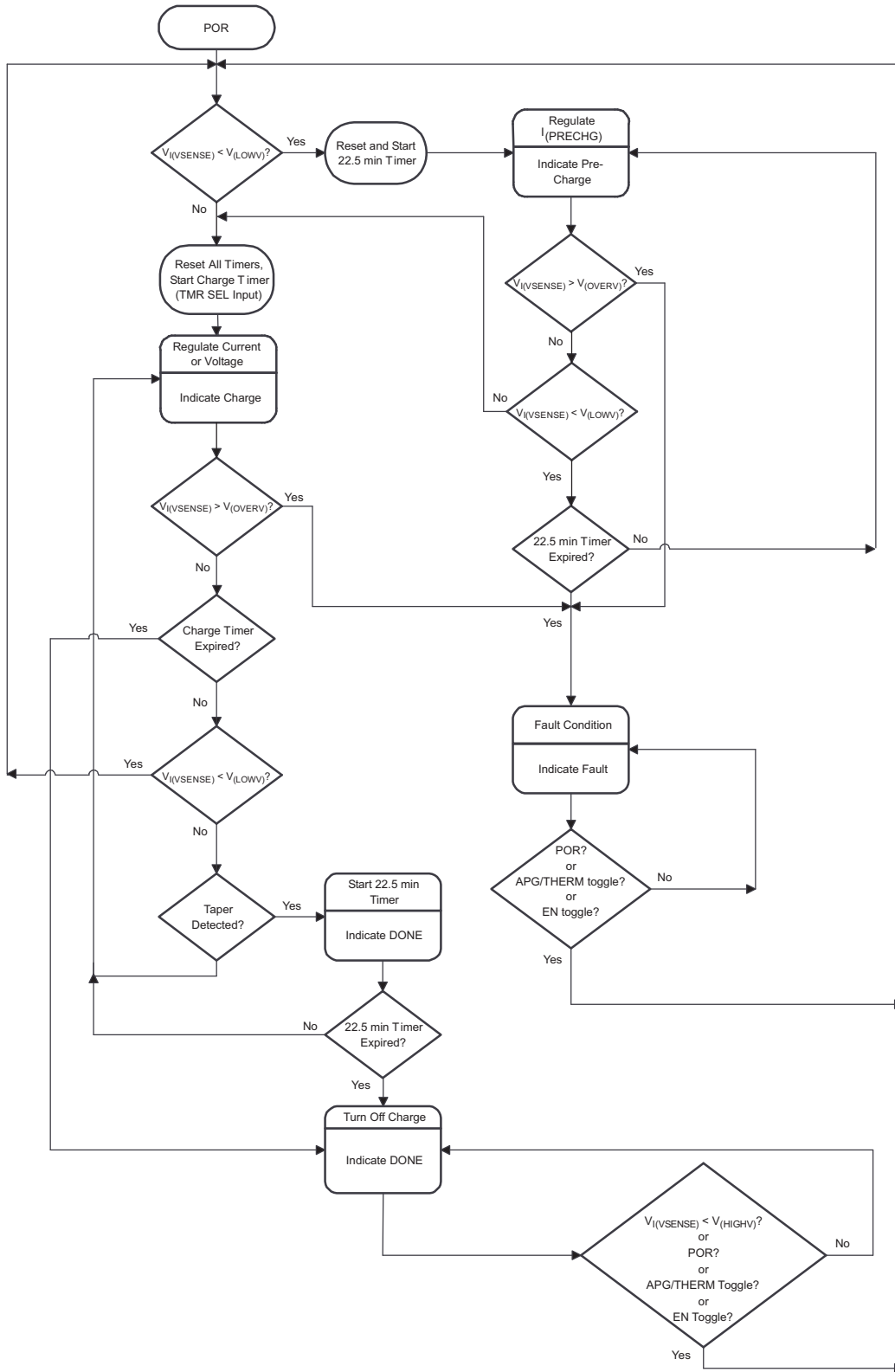

Figure 15. Operational Flow Chart

Charge Qualification and Preconditioning

The bq2400x starts a charge cycle when power is applied while a battery is present. Charge qualification is based on battery voltage and the APG/THERM input.

As shown in the block diagram, the internal LowV comparator output prevents fast-charging a deeply depleted battery. When set, charging current is provided by a dedicated precharge current source. The precharge timer limits the precharge duration. The precharge current also minimizes heat dissipation in the pass element during the initial stage of charge.

The APG/THERM input can also be configured to monitor either the adapter power or the battery temperature using a thermistor. The bq2400x suspends charge if this input is outside the limits set by the user. Refer to the APG/THERM input section for additional details.

APG/THERM Input

The bq2400x continuously monitors temperature or system input voltage by measuring the voltage between the APG/THERM (adapter power good/thermistor) and GND. For temperature, a negative- or a positive-temperature coefficient thermistor (NTC, PTC) and an external voltage divider typically develop this voltage (see Figure 16). The bq2400x compares this voltage against its internal $V_{(TP1)}$ and $V_{(TP2)}$ thresholds to determine if charging is allowed. (See Figure 17.)

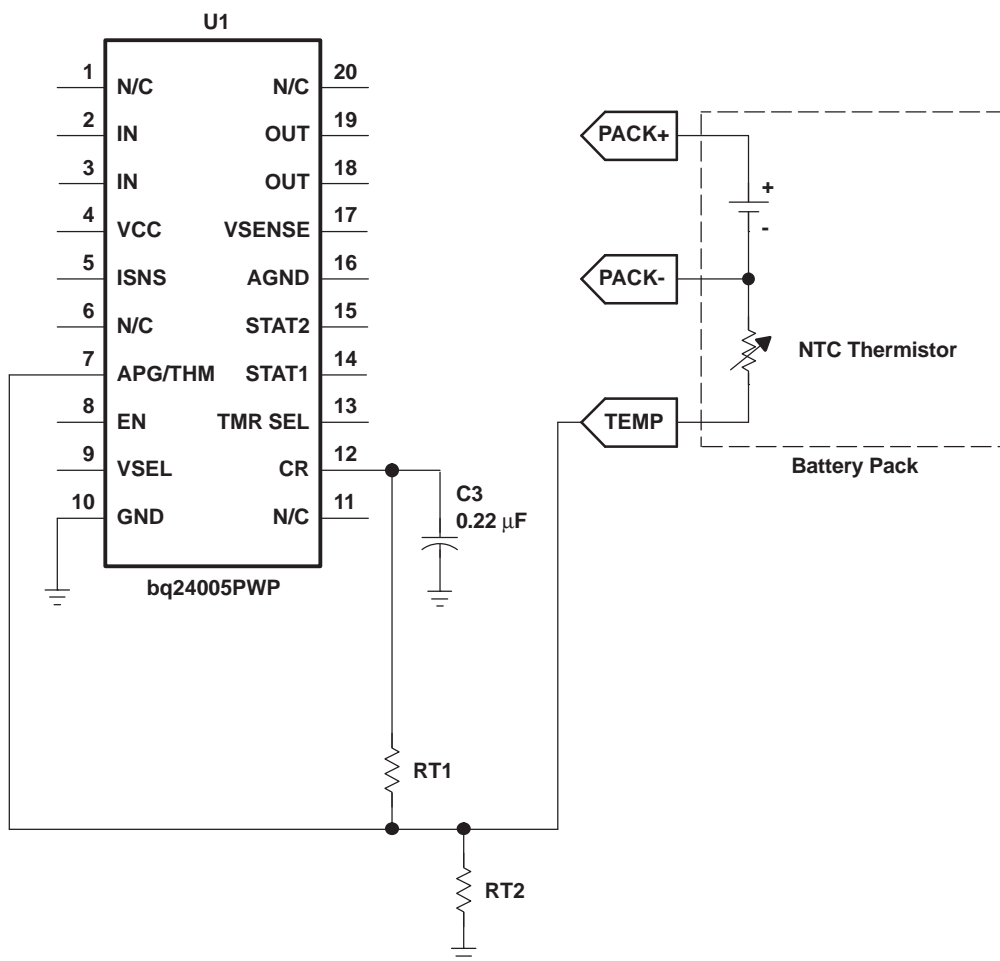

Figure 16. Temperature Sensing Circuit

If the charger designs incorporate a thermistor, the resistor divider RT1 and RT2 is calculated by using the following two equations.

First, calculate RT2.

$$RT2 = \frac{V_B R_H R_C \left[\frac{1}{V_C} - \frac{1}{V_H} \right]}{R_H \left(\frac{V_B}{V_H} - 1 \right) - R_C \left(\frac{V_B}{V_C} - 1 \right)}$$

then use the resistor value to find RT1.

$$RT1 = \frac{\frac{V_B}{V_C} - 1}{\frac{1}{RT2} + \frac{1}{R_C}}$$

Where:

$V_B = V_{CR}$ (bias voltage)

R_H = Resistance of the thermistor at the desired hot trip threshold

R_C = Resistance of the thermistor at the desired cold trip threshold

V_H = VP2 or the lower APG trip threshold

V_C = VP2 or the upper APG trip threshold

RT1 = Top resistor in the divider string

RT2 = Bottom resistor in the divider string

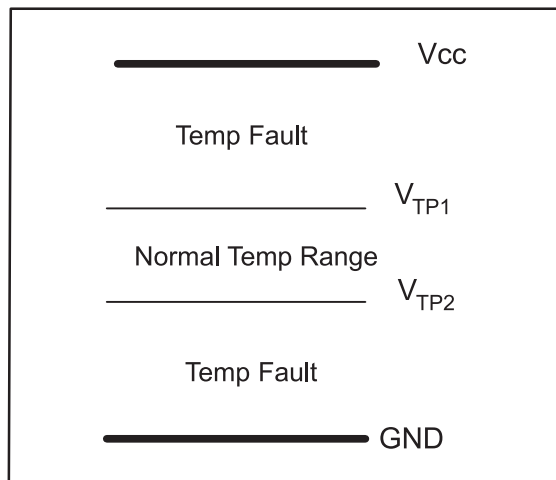

Figure 17. Temperature Threshold

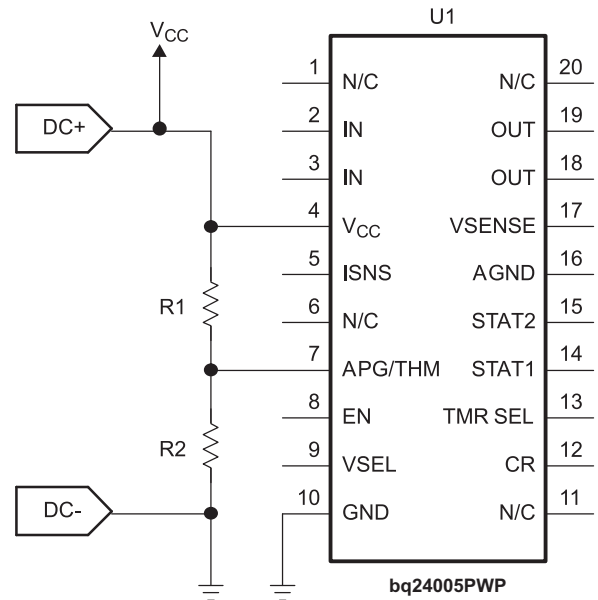

Figure 18. APG Sensing Circuit

Values of resistors R1 and R2 can be calculated using the following equation:

$$V_{(APG)} = V_{CC} \frac{R2}{(R1 + R2)}$$

where $V_{(APG)}$ is the voltage at the APG/THM pin.

Current Regulation

The bq2400x provides current regulation while the battery-pack voltage is less than the regulation voltage. The current regulation loop effectively amplifies the error between a reference signal, V_{ilim} , and the drop across the external sense resistor, R_{SNS} .

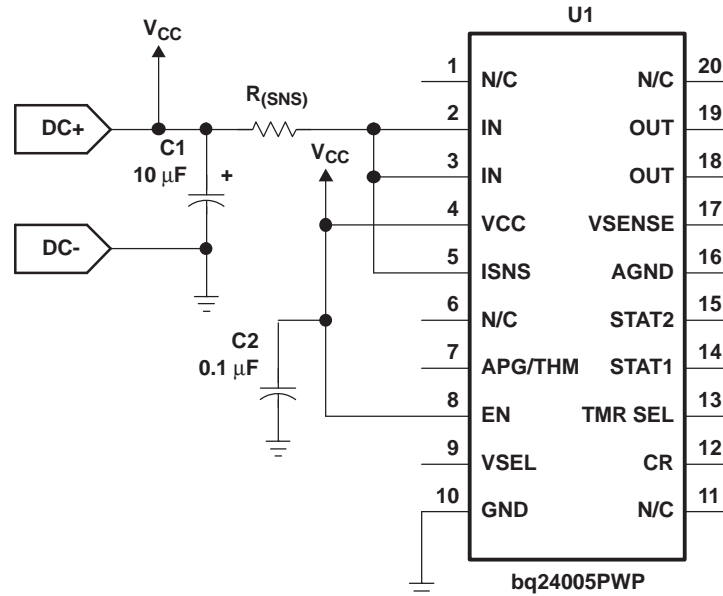

Figure 19. Current Sensing Circuit

Charge current feedback, applied through pin ISNS, maintains regulation around a threshold of V_{ilim} . The following formula calculates the value of the sense resistor:

$$R_{(SNS)} = \frac{V_{(ilim)}}{I_{(REG)}}$$

where $I_{(REG)}$ is the desired charging current.

Voltage Monitoring and Regulation

Voltage regulation feedback is through pin VSENSE. This input is tied directly to the positive side of the battery pack. The bq2400x supports cells with either coke (8.2 V) or graphite (8.4 V) anode. Pin VSEL selects the charge regulation voltage.

VSEL STATE (see Note)	CHARGE REGULATION VOLTAGE
Low	8.2 V
High	8.4 V

NOTE: VSEL should not be left floating.

Charge Termination

The bq2400x continues with the charge cycle until termination by one of the two possible termination conditions:

Maximum Charge Time: The bq2400x sets the maximum charge time through pin TMRSEL. The TMR SEL pin allows the user to select between three different total charge-time timers (3, 4, 5, or 6 hours). The charge timer is initiated after the preconditioning

phase of the charge and is reset at the beginning of a new charge cycle. Note that in the case of a fault condition, such as an out-of-range signal on the APG/THERM input or a thermal shutdown, the bq2400x suspends the timer.

TMRSEL STATE	CHARGE TIME
Floating ⁽¹⁾	3 hours
Low	6 hours
High	4.5 hours

⁽¹⁾To improve noise immunity, it is recommended that a minimum of 10 pF capacitor be tied to Vss on a floating pin.

Minimum Current: The bq2400x monitors the charging current during the voltage regulation phase. The bq2400x initiates a 22-minute timer once the current falls below the taperdet trip threshold. Fast charge is terminated once the 22-minute timer expires.

Charge Status Display

The three available options allow the user to configure the charge status display for single LED (bq24004), two individual LEDs (bq24005) or a bicolor LED (bq24006). The output stage is totem pole for the bq24004 and bq24006 and open-drain for the bq24005. The following tables summarize the operation of the three options:

Table 1. bq24004 (Single LED)

CHARGE STATE	STAT1
Precharge	ON (LOW)
Fast charge	ON (LOW)
FAULT	Flashing (1 Hz, 50% duty cycle)

Table 1. bq24004 (Single LED) (continued)

CHARGE STATE	STAT1
Done (>90%)	OFF (HIGH)
Sleep-mode	OFF (HIGH)
APG/Therm invalid	OFF (HIGH)
Thermal shutdown	OFF (HIGH)
Battery absent	OFF (HIGH)

Table 2. bq24005 (2 Individual LEDs)

CHARGE STATE	STAT1 (RED)	STAT2 (GREEN)
Precharge	ON (LOW)	OFF
Fast charge	ON (LOW)	OFF
FAULT	Flashing (1 Hz, 50% duty cycle)	OFF
Done (>90%)	OFF	ON (LOW)
Sleep-mode	OFF	OFF
APG/Therm invalid	OFF	OFF
Thermal shutdown	OFF	OFF

Table 2. bq24005 (2 Individual LEDs) (continued)

CHARGE STATE	STAT1 (RED)	STAT2 (GREEN)
Battery absent	OFF	OFF ⁽¹⁾

⁽¹⁾If thermistor is used, then the Green LED is off.

Table 3. bq24006 (Single Bicolor LED)

CHARGE STATE	LED1 (RED)	LED2 (GREEN)	APPARENT COLOR
Precharge	ON (LOW)	OFF (HIGH)	RED
Fast charge	ON (LOW)	OFF (HIGH)	RED
FAULT	ON (LOW)	ON (LOW)	YELLOW
Done (>90%)	OFF (HIGH)	ON (LOW)	GREEN
Sleep-mode	OFF (HIGH)	OFF (HIGH)	OFF
APG/Therm invalid	OFF (HIGH)	OFF (HIGH)	OFF
Thermal shutdown	OFF (HIGH)	OFF (HIGH)	OFF
Battery absent	OFF (HIGH)	OFF (HIGH) ⁽¹⁾	OFF ⁽¹⁾

⁽¹⁾If thermistor is used, then the Green LED is off.

Thermal Shutdown

The bq2400x monitors the junction temperature T_j of the DIE and suspends charging if T_j exceeds 165°C. Charging resumes when T_j falls below 155°C.

DETAILED DESCRIPTION

POWER FET

The integrated transistor is a P-channel MOSFET. The power FET features a reverse-blocking Schottky diode, which prevents current flow from OUT to IN.

An internal thermal-sense circuit shuts off the power FET when the junction temperature rises to approximately 165°C. Hysteresis is built into the thermal sense circuit. After the device has cooled approximately 10°C, the power FET turns back on. The power FET continues to cycle off and on until the fault is removed.

CURRENT SENSE

The bq2400x regulates current by sensing, on the ISNS pin, the voltage drop developed across an external sense resistor. The sense resistor must be placed between the supply voltage (V_{cc}) and the input of the IC (IN pins).

VOLTAGE SENSE

To achieve maximum voltage regulation accuracy, the bq2400x uses the feedback on the VSENSE pin. Externally, this pin should be connected as close to the battery cell terminals as possible. For additional safety, a 10-kΩ internal pullup resistor is connected between the VSENSE and OUT pins.

ENABLE (EN)

The logic EN input is used to enable or disable the IC. A high-level signal on this pin enables the bq2400x. A low-level signal disables the IC and places the device in a low-power standby mode.

THERMAL INFORMATION

THERMALLY ENHANCED TSSOP-20

The thermally enhanced PWP package is based on the 20-pin TSSOP, but includes a thermal pad (see [Figure 20](#)) to provide an effective thermal contact between the IC and the PWB.

Traditionally, surface mount and power have been mutually exclusive terms. A variety of scaled-down TO220-type packages have leads formed as gull wings to make them applicable for surface-mount applications. These packages, however, suffer from several shortcomings: they do not address the very low profile requirements (<2 mm) of many of today's advanced systems, and they do not offer a pin-count high enough to accommodate increasing integration. On the other hand, traditional low-power surface-mount packages require power-dissipation derating that severely limits the usable range of many high-performance analog circuits.

The PWP package (thermally enhanced TSSOP) combines fine-pitch surface-mount technology with thermal performance comparable to much larger power packages.

The PWP package is designed to optimize the heat transfer to the PWB. Because of the very small size and limited mass of a TSSOP package, thermal enhancement is achieved by improving the thermal conduction paths that remove heat from the component. The thermal pad is formed using a lead-frame design (patent pending) and manufacturing technique to provide the user with direct connection to the heat-generating IC. When this pad is soldered or otherwise coupled to an external heat dissipator, high power dissipation in the ultrathin, fine-pitch, surface-mount package can be reliably achieved.

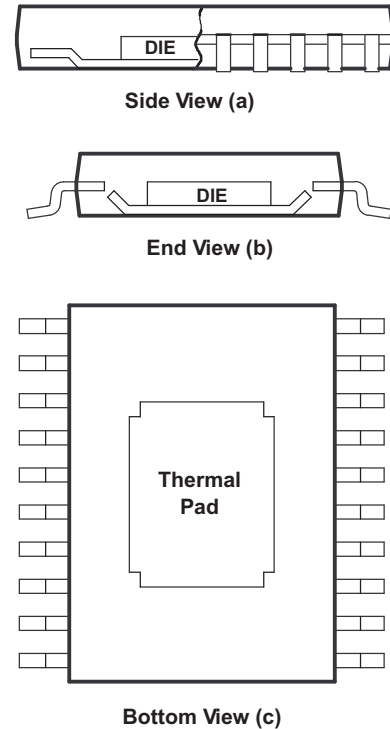

Figure 20. Views of Thermally Enhanced PWP Package

Because the conduction path has been enhanced, power-dissipation capability is determined by the thermal considerations in the PWB design. For example, simply adding a localized copper plane (heat-sink surface), which is coupled to the thermal pad, enables the PWP package to dissipate 2.5 W in free air. (Reference [Figure 22\(a\)](#), 8 cm² of copper heat sink and natural convection.) Increasing the heat-sink size increases the power dissipation range for the component. The power dissipation limit can be further improved by adding airflow to a PWB/IC assembly. (See [Figure 22\(b\)](#) and [Figure 22\(c\)](#).) The line drawn at 0.3 cm² in [Figure 21](#) and [Figure 22](#) indicates performance at the minimum recommended heat-sink size.

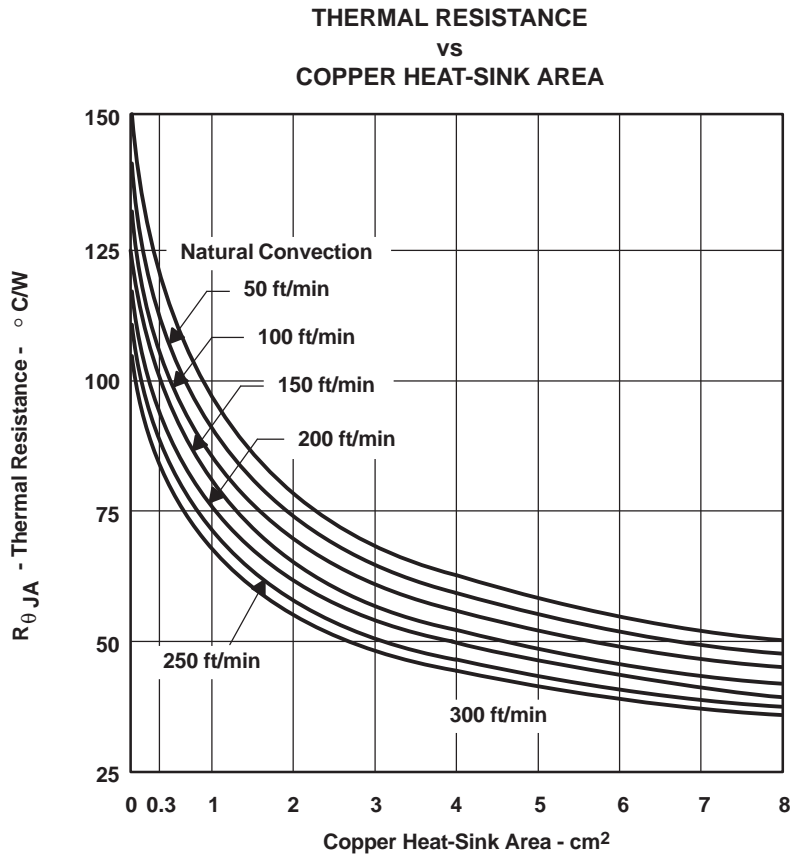
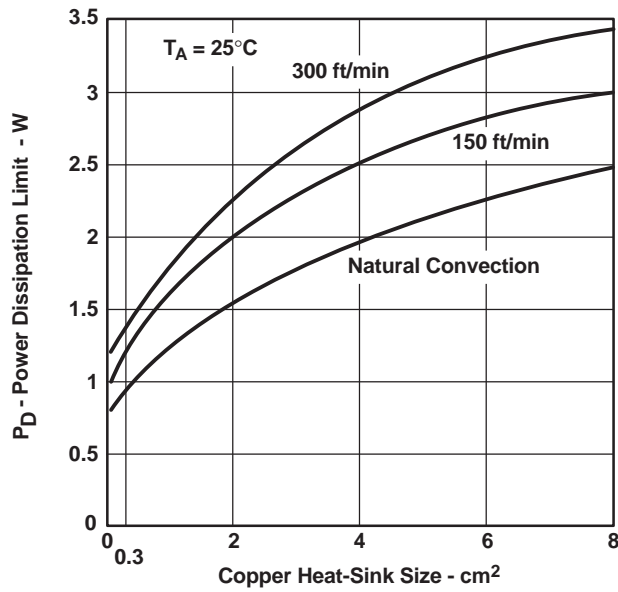
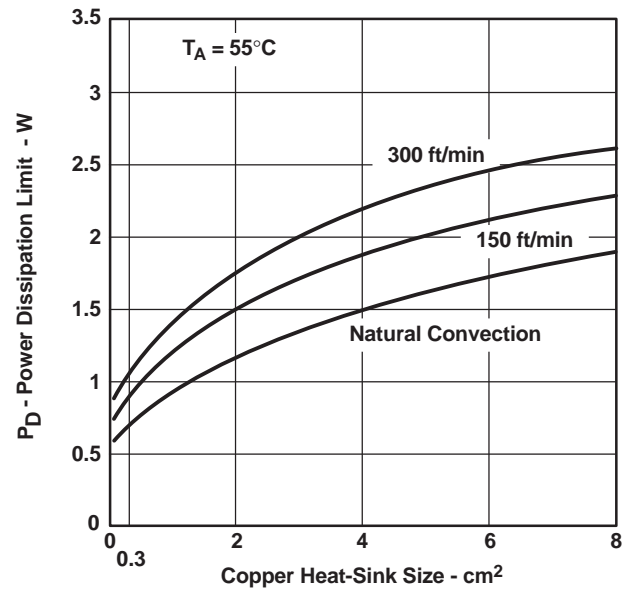

Figure 21.



(a)



(b)

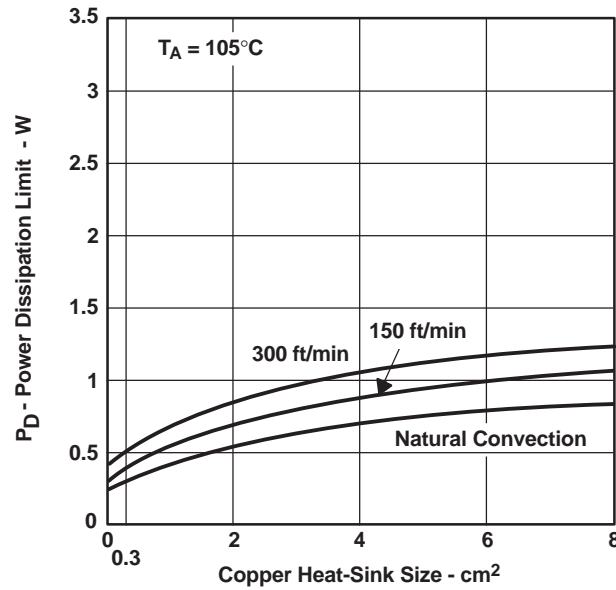

(c)

Figure 22. Power Ratings of the PWP Package at Ambient Temperatures of 25°C, 55°C, and 105°C

PACKAGING INFORMATION

Orderable Device	Status ⁽¹⁾	Package Type	Package Drawing	Pins	Package Qty	Eco Plan ⁽²⁾	Lead/ Ball Finish	MSL Peak Temp ⁽³⁾	Samples (Requires Login)
BQ24004PWP	ACTIVE	HTSSOP	PWP	20	70	Green (RoHS & no Sb/Br)	CU NIPDAU	Level-2-260C-1 YEAR	
BQ24004PWPG4	ACTIVE	HTSSOP	PWP	20	70	Green (RoHS & no Sb/Br)	CU NIPDAU	Level-2-260C-1 YEAR	
BQ24004PWPR	ACTIVE	HTSSOP	PWP	20	2000	Green (RoHS & no Sb/Br)	CU NIPDAU	Level-2-260C-1 YEAR	
BQ24004PWPRG4	ACTIVE	HTSSOP	PWP	20	2000	Green (RoHS & no Sb/Br)	CU NIPDAU	Level-2-260C-1 YEAR	
BQ24005PWP	ACTIVE	HTSSOP	PWP	20	70	Green (RoHS & no Sb/Br)	CU NIPDAU	Level-2-260C-1 YEAR	
BQ24005PWPG4	ACTIVE	HTSSOP	PWP	20	70	Green (RoHS & no Sb/Br)	CU NIPDAU	Level-2-260C-1 YEAR	
BQ24005PWPR	ACTIVE	HTSSOP	PWP	20	2000	Green (RoHS & no Sb/Br)	CU NIPDAU	Level-2-260C-1 YEAR	
BQ24005PWPRG4	ACTIVE	HTSSOP	PWP	20	2000	Green (RoHS & no Sb/Br)	CU NIPDAU	Level-2-260C-1 YEAR	
BQ24006PWP	ACTIVE	HTSSOP	PWP	20	70	Green (RoHS & no Sb/Br)	CU NIPDAU	Level-2-260C-1 YEAR	
BQ24006PWPG4	ACTIVE	HTSSOP	PWP	20	70	Green (RoHS & no Sb/Br)	CU NIPDAU	Level-2-260C-1 YEAR	
BQ24006PWPR	ACTIVE	HTSSOP	PWP	20	2000	Green (RoHS & no Sb/Br)	CU NIPDAU	Level-2-260C-1 YEAR	
BQ24006PWPRG4	ACTIVE	HTSSOP	PWP	20	2000	Green (RoHS & no Sb/Br)	CU NIPDAU	Level-2-260C-1 YEAR	

⁽¹⁾ The marketing status values are defined as follows:

ACTIVE: Product device recommended for new designs.

LIFEBUY: TI has announced that the device will be discontinued, and a lifetime-buy period is in effect.

NRND: Not recommended for new designs. Device is in production to support existing customers, but TI does not recommend using this part in a new design.

PREVIEW: Device has been announced but is not in production. Samples may or may not be available.

OBSOLETE: TI has discontinued the production of the device.

⁽²⁾ Eco Plan - The planned eco-friendly classification: Pb-Free (RoHS), Pb-Free (RoHS Exempt), or Green (RoHS & no Sb/Br) - please check <http://www.ti.com/productcontent> for the latest availability information and additional product content details.

TBD: The Pb-Free/Green conversion plan has not been defined.

Pb-Free (RoHS): TI's terms "Lead-Free" or "Pb-Free" mean semiconductor products that are compatible with the current RoHS requirements for all 6 substances, including the requirement that lead not exceed 0.1% by weight in homogeneous materials. Where designed to be soldered at high temperatures, TI Pb-Free products are suitable for use in specified lead-free processes.

Pb-Free (RoHS Exempt): This component has a RoHS exemption for either 1) lead-based flip-chip solder bumps used between the die and package, or 2) lead-based die adhesive used between the die and leadframe. The component is otherwise considered Pb-Free (RoHS compatible) as defined above.

Green (RoHS & no Sb/Br): TI defines "Green" to mean Pb-Free (RoHS compatible), and free of Bromine (Br) and Antimony (Sb) based flame retardants (Br or Sb do not exceed 0.1% by weight in homogeneous material)

⁽³⁾ MSL, Peak Temp. -- The Moisture Sensitivity Level rating according to the JEDEC industry standard classifications, and peak solder temperature.

Important Information and Disclaimer: The information provided on this page represents TI's knowledge and belief as of the date that it is provided. TI bases its knowledge and belief on information provided by third parties, and makes no representation or warranty as to the accuracy of such information. Efforts are underway to better integrate information from third parties. TI has taken and continues to take reasonable steps to provide representative and accurate information but may not have conducted destructive testing or chemical analysis on incoming materials and chemicals. TI and TI suppliers consider certain information to be proprietary, and thus CAS numbers and other limited information may not be available for release.

In no event shall TI's liability arising out of such information exceed the total purchase price of the TI part(s) at issue in this document sold by TI to Customer on an annual basis.

TAPE AND REEL INFORMATION
REEL DIMENSIONS

TAPE DIMENSIONS

A0	Dimension designed to accommodate the component width
B0	Dimension designed to accommodate the component length
K0	Dimension designed to accommodate the component thickness
W	Overall width of the carrier tape
P1	Pitch between successive cavity centers

TAPE AND REEL INFORMATION

*All dimensions are nominal

Device	Package Type	Package Drawing	Pins	SPQ	Reel Diameter (mm)	Reel Width W1 (mm)	A0 (mm)	B0 (mm)	K0 (mm)	P1 (mm)	W (mm)	Pin1 Quadrant
BQ24004PWPR	HTSSOP	PWP	20	2000	330.0	16.4	6.95	7.1	1.6	8.0	16.0	Q1
BQ24005PWPR	HTSSOP	PWP	20	2000	330.0	16.4	6.95	7.1	1.6	8.0	16.0	Q1
BQ24006PWPR	HTSSOP	PWP	20	2000	330.0	16.4	6.95	7.1	1.6	8.0	16.0	Q1

TAPE AND REEL BOX DIMENSIONS

*All dimensions are nominal

Device	Package Type	Package Drawing	Pins	SPQ	Length (mm)	Width (mm)	Height (mm)
BQ24004PWPR	HTSSOP	PWP	20	2000	367.0	367.0	38.0
BQ24005PWPR	HTSSOP	PWP	20	2000	367.0	367.0	38.0
BQ24006PWPR	HTSSOP	PWP	20	2000	367.0	367.0	38.0

MECHANICAL DATA

PWP (R-PDSO-G20)

PowerPAD™ PLASTIC SMALL OUTLINE



4073225-4/1 05/11

- NOTES:
- All linear dimensions are in millimeters.
 - This drawing is subject to change without notice.
 - Body dimensions do not include mold flash or protrusions. Mold flash and protrusion shall not exceed 0.15 per side.
 - This package is designed to be soldered to a thermal pad on the board. Refer to Technical Brief, PowerPad Thermally Enhanced Package, Texas Instruments Literature No. SLMA002 for information regarding recommended board layout. This document is available at www.ti.com <<http://www.ti.com>>.
 - See the additional figure in the Product Data Sheet for details regarding the exposed thermal pad features and dimensions.
 - Falls within JEDEC MO-153

PowerPAD is a trademark of Texas Instruments.

THERMAL PAD MECHANICAL DATA

PWP (R-PDSO-G20) PowerPAD™ SMALL PLASTIC OUTLINE

THERMAL INFORMATION

This PowerPAD™ package incorporates an exposed thermal pad that is designed to be attached to a printed circuit board (PCB). The thermal pad must be soldered directly to the PCB. After soldering, the PCB can be used as a heatsink. In addition, through the use of thermal vias, the thermal pad can be attached directly to the appropriate copper plane shown in the electrical schematic for the device, or alternatively, can be attached to a special heatsink structure designed into the PCB. This design optimizes the heat transfer from the integrated circuit (IC).

For additional information on the PowerPAD package and how to take advantage of its heat dissipating abilities, refer to Technical Brief, PowerPAD Thermally Enhanced Package, Texas Instruments Literature No. SLMA002 and Application Brief, PowerPAD Made Easy, Texas Instruments Literature No. SLMA004. Both documents are available at www.ti.com.

The exposed thermal pad dimensions for this package are shown in the following illustration.

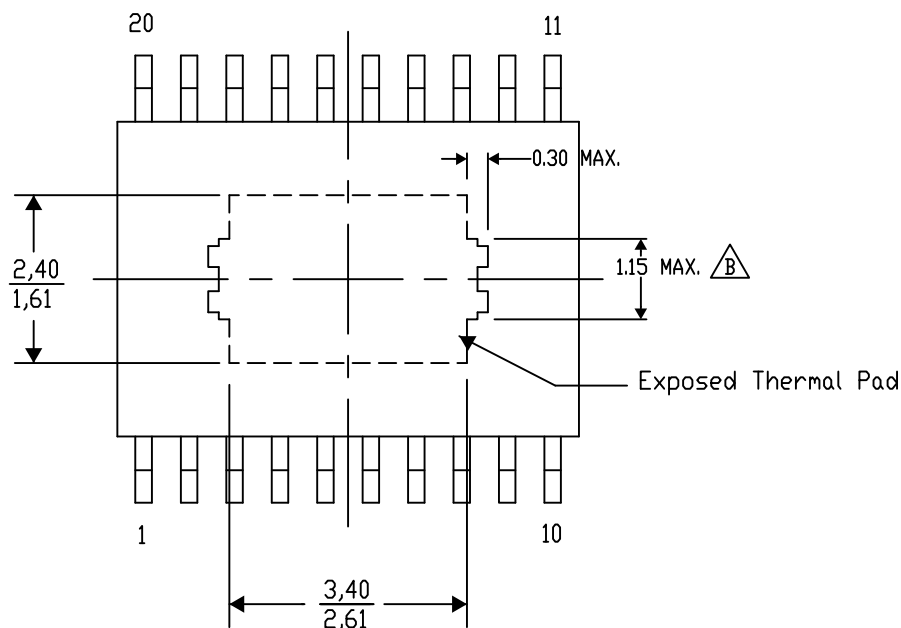

Top View

Exposed Thermal Pad Dimensions

4206332-15/AC 07/12

NOTE: A. All linear dimensions are in millimeters

 Exposed tie strap features may not be present.

PowerPAD is a trademark of Texas Instruments

PWP (R-PDSO-G20)

PowerPAD™ PLASTIC SMALL OUTLINE

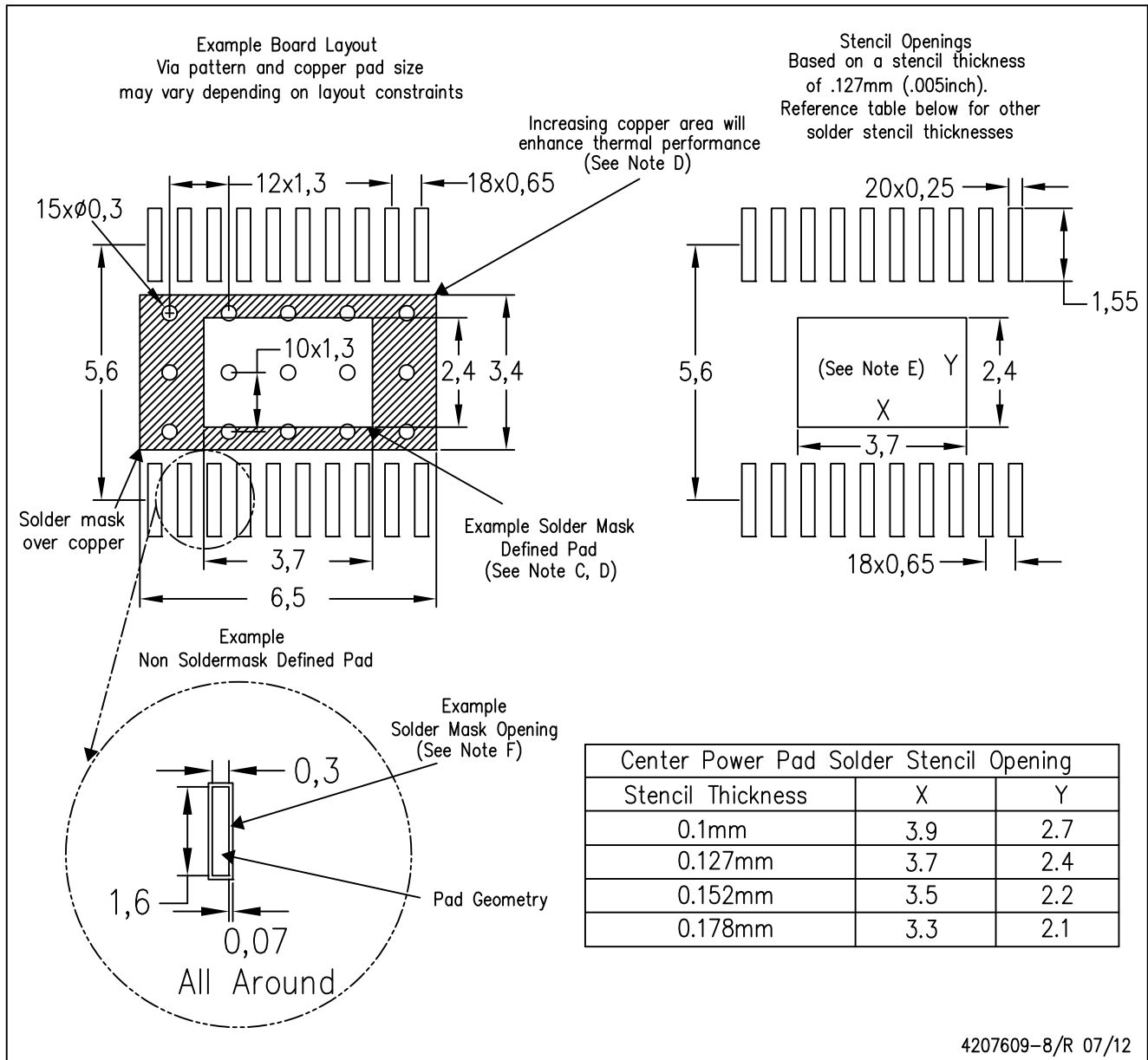

- NOTES:
- A. All linear dimensions are in millimeters.
 - B. This drawing is subject to change without notice.
 - C. Customers should place a note on the circuit board fabrication drawing not to alter the center solder mask defined pad.
 - D. This package is designed to be soldered to a thermal pad on the board. Refer to Technical Brief, PowerPad Thermally Enhanced Package, Texas Instruments Literature No. SLMA002, SLMA004, and also the Product Data Sheets for specific thermal information, via requirements, and recommended board layout. These documents are available at www.ti.com <<http://www.ti.com>>. Publication IPC-7351 is recommended for alternate designs.
 - E. Laser cutting apertures with trapezoidal walls and also rounding corners will offer better paste release. Customers should contact their board assembly site for stencil design recommendations. Example stencil design based on a 50% volumetric metal load solder paste. Refer to IPC-7525 for other stencil recommendations.
 - F. Customers should contact their board fabrication site for solder mask tolerances between and around signal pads.

IMPORTANT NOTICE

Texas Instruments Incorporated and its subsidiaries (TI) reserve the right to make corrections, enhancements, improvements and other changes to its semiconductor products and services per JESD46C and to discontinue any product or service per JESD48B. Buyers should obtain the latest relevant information before placing orders and should verify that such information is current and complete. All semiconductor products (also referred to herein as "components") are sold subject to TI's terms and conditions of sale supplied at the time of order acknowledgment.

TI warrants performance of its components to the specifications applicable at the time of sale, in accordance with the warranty in TI's terms and conditions of sale of semiconductor products. Testing and other quality control techniques are used to the extent TI deems necessary to support this warranty. Except where mandated by applicable law, testing of all parameters of each component is not necessarily performed.

TI assumes no liability for applications assistance or the design of Buyers' products. Buyers are responsible for their products and applications using TI components. To minimize the risks associated with Buyers' products and applications, Buyers should provide adequate design and operating safeguards.

TI does not warrant or represent that any license, either express or implied, is granted under any patent right, copyright, mask work right, or other intellectual property right relating to any combination, machine, or process in which TI components or services are used. Information published by TI regarding third-party products or services does not constitute a license to use such products or services or a warranty or endorsement thereof. Use of such information may require a license from a third party under the patents or other intellectual property of the third party, or a license from TI under the patents or other intellectual property of TI.

Reproduction of significant portions of TI information in TI data books or data sheets is permissible only if reproduction is without alteration and is accompanied by all associated warranties, conditions, limitations, and notices. TI is not responsible or liable for such altered documentation. Information of third parties may be subject to additional restrictions.

Resale of TI components or services with statements different from or beyond the parameters stated by TI for that component or service voids all express and any implied warranties for the associated TI component or service and is an unfair and deceptive business practice. TI is not responsible or liable for any such statements.

Buyer acknowledges and agrees that it is solely responsible for compliance with all legal, regulatory and safety-related requirements concerning its products, and any use of TI components in its applications, notwithstanding any applications-related information or support that may be provided by TI. Buyer represents and agrees that it has all the necessary expertise to create and implement safeguards which anticipate dangerous consequences of failures, monitor failures and their consequences, lessen the likelihood of failures that might cause harm and take appropriate remedial actions. Buyer will fully indemnify TI and its representatives against any damages arising out of the use of any TI components in safety-critical applications.

In some cases, TI components may be promoted specifically to facilitate safety-related applications. With such components, TI's goal is to help enable customers to design and create their own end-product solutions that meet applicable functional safety standards and requirements. Nonetheless, such components are subject to these terms.

No TI components are authorized for use in FDA Class III (or similar life-critical medical equipment) unless authorized officers of the parties have executed a special agreement specifically governing such use.

Only those TI components which TI has specifically designated as military grade or "enhanced plastic" are designed and intended for use in military/aerospace applications or environments. Buyer acknowledges and agrees that any military or aerospace use of TI components which have **not** been so designated is solely at the Buyer's risk, and that Buyer is solely responsible for compliance with all legal and regulatory requirements in connection with such use.

TI has specifically designated certain components which meet ISO/TS16949 requirements, mainly for automotive use. Components which have not been so designated are neither designed nor intended for automotive use; and TI will not be responsible for any failure of such components to meet such requirements.

Products

Audio	www.ti.com/audio
Amplifiers	amplifier.ti.com
Data Converters	dataconverter.ti.com
DLP® Products	www.dlp.com
DSP	dsp.ti.com
Clocks and Timers	www.ti.com/clocks
Interface	interface.ti.com
Logic	logic.ti.com
Power Mgmt	power.ti.com
Microcontrollers	microcontroller.ti.com
RFID	www.ti-rfid.com
OMAP Mobile Processors	www.ti.com/omap
Wireless Connectivity	www.ti.com/wirelessconnectivity

Applications

Automotive and Transportation	www.ti.com/automotive
Communications and Telecom	www.ti.com/communications
Computers and Peripherals	www.ti.com/computers
Consumer Electronics	www.ti.com/consumer-apps
Energy and Lighting	www.ti.com/energy
Industrial	www.ti.com/industrial
Medical	www.ti.com/medical
Security	www.ti.com/security
Space, Avionics and Defense	www.ti.com/space-avionics-defense
Video and Imaging	www.ti.com/video

TI E2E Community e2e.ti.com