

## ***Battery Charger Termination Issues With System Load Applied Across Battery While Charging***

---

*PMP Portable Power*

### **ABSTRACT**

Battery charger ICs base their full charge termination on either peak voltage detect (PVD/dV) for nickel chemistries (bq2000, bq2002, and bq2004) or current taper for Li-ion batteries (bq24010, bq24020, and bq2954). Applying a system load to the output of the charger, while charging the battery, may result in an altered voltage or current reading and thus an improper termination. This application report offers several chemistry-specific solutions. The first section covers Li-ion chemistries, and the second section covers nickel chemistries.

---

### **Problems With Li-Ion Termination:**

The typical problem with applying a system load to the output of a Li-ion battery charger, while charging the battery, is the loss of properly terminating the charge cycle. This often results in a maximum timeout fault condition which prohibits future charging without cycling the input power. Li-ion battery chargers designed solely for battery charging make charging and termination decisions based on the current and voltage out of the charger. Load currents cause three common problems.

- If the load current is greater than the taper threshold, then the taper timer is not set, and normal termination does not occur. The taper timer is set once the battery is considered full, typically at one-tenth the fast charge current, to allow 30 minutes of additional charging to insure approximately 100% charge capacity.
- If the average load is small, such that the taper timer is set, but has frequent load pulses above the taper threshold, this also continually resets the taper timer and prevents taper termination.
- If the charger is in the precharge mode, typically < 3 V (per cell), then the battery is charged at one-tenth the fast charge rate to determine if the battery will take a charge. Typically after 30 minutes, if the battery voltage is not above 3 V, the charger declares a dead battery and enters a fault mode. Applying a system load, while the charger is in precharge conditioning mode, reduces or eliminates the precharge current potentially keeping the cell below 3 V, causing the charger to enter fault mode.

## Solution to Termination Issue of Li-Ion Chargers With Parallel System Loads

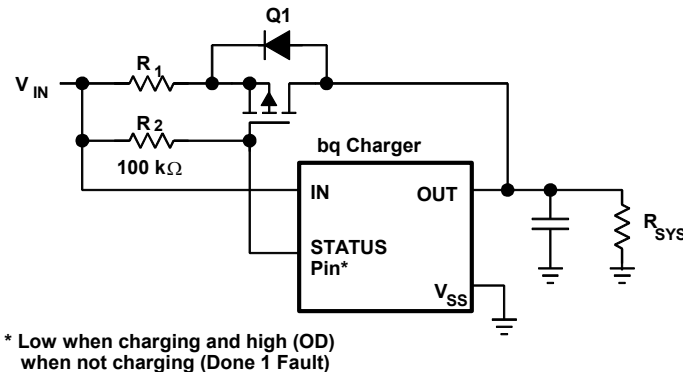

**Figure 1. Current Supplement Circuit**

- **Disable Termination** - Many chargers have TE or TTE options to disable the taper or termination effectively, making the part act as an LDO regulator. The charger output continuously powers the system and allows an unlimited amount of time for the battery to reach full capacity without the charger entering a fault mode.
- **Supplemental Load Current** - If the system load is constant (DC), it can effectively be subtracted out by supplementing an equivalent current from the input to the battery via a resistor and P-CH FET in series (see Figure 1). The concept is to supply the system load current from the input source during voltage regulation so that only the battery is receiving the charger's current, thus making a proper termination. To calculate R1, use the following equations:

$$I_{sys} = \frac{(V_{in} - V_{bat})}{R1} \quad (1)$$

Therefore,

$$R1 = \frac{(V_{in} - V_{sys})}{I_{sys}} \quad (2)$$

Where:

$I_{sys}$  is the supplementing system load current

$V_{in}$  is the charger input voltage

$V_{bat}$  is the battery voltage during voltage regulation (4.2 V/cell)

Note that when charging is terminated for any reason, the STAT pin goes high and turns off the supplemental current. R2 is used as a pullup resistor if the STAT pin is an open-drain/collector transistor.

- **Filter Pulsed Current Sense Signal.** If the system has a small average load but infrequently pulses the charger current above the taper threshold, then a filter capacitor across the current sense signal (ISET resistor) can be used to filter the spike and avoid resetting the taper timer. The bq24010 and bq24020 ICs have an ISET pin which is a scaled

current reference ( $I_{out}/320$ ). This scaled current through the ISET resistor produces a voltage relative to the output current and is compared to the taper threshold voltage.

- Power System From the Input Source.** If the load is dynamic, one solution is to power the system from the charger's input and switch the system load to the battery if the input is lost (see Figure 2). This switching between power sources is controlled by the power-good status pin (/PG) option offered on the bq24010 and bq24020 chargers. When the input source is present, the /PG pin is low, which turns on Q1/Q2 and ties the input source to the system load. Transistors Q3 and Q4 are off, which disconnects the battery from the system. If the power goes away, the /PG pin is pulled high, turning off Q1/Q2 (disconnects the input from the system) and turning on Q3 and Q4 which connects the battery to the system. Note that Q2 is optional if there is not an issue of the battery discharging to a load on the input when the input is not powered. If Q1 through Q4 are chosen with turnon thresholds of  $\sim 3.5$  V, then there is soft-switching during power transfer (i.e., FETs are in their linear region with minimal shoot-through current).

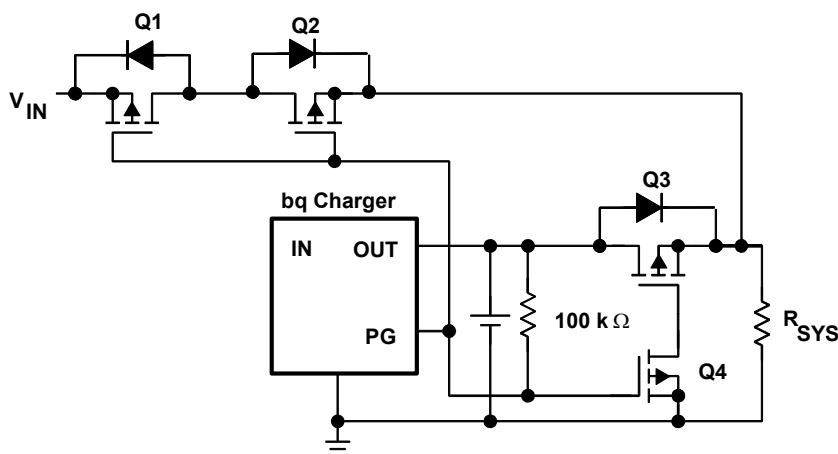

Figure 2. System Load Switched From Input to Battery With Loss of Input Power

## Problems With NiMH/NiCd Terminations:

The typical problem with applying a system load to the output of a nickel battery charger (across the battery) is often false termination of the charge cycle. Early termination results in a partially charged battery and reduced running time which can be a problem. Not detecting termination can lead to overstress and shortened life of the battery pack. A nickel battery is fast charged with a constant current (typically between  $C/2$  to  $2C$ , where  $C$  is equivalent to the amp-hour rating of the battery). When the nickel battery reaches full capacity, further charging results in the excess power being dissipated as heat from the battery. This chemical reaction also results in the cell voltage dropping off several millivolts, which is a common method for detecting a full battery. Ambient temperature also can modify the voltage charge profile. System load currents can cause two common problems.

- When the system is connected across the battery, the charge current is shared between the system and the charger. A change in load by the system adds or subtracts from the battery charge current. The change in current going to the battery creates a change in voltage across the battery's impedance. A drop in voltage may be interpreted as a PVD or  $-dV$ .

Because this voltage drop resulted from a change in current going to the battery and not from a chemical change of a full battery, the termination may have been implemented too early.

- If the system load is constant, the charging current to the battery is constant, but reduced by the amount going to the system. If the actual current going into the battery is below  $C/3$ , then there is a potential problem with detecting the hump of a full battery. Note that the battery's voltage charge profile flattens with increased ambient temperatures (hump is less pronounced). Thus, both the amount of charge current and the ambient temperature have an effect on the amplitude of the voltage hump that occurs when the battery reaches full capacity.

## Solution to Termination Issue of NiMH/NiCd Chargers With Parallel System Loads

- **Use dT/dt Termination.** For a nickel battery with a dynamic system load, it is more reliable to use the rise in temperature with respect to time ( $dT/dt$ ) as the full charge detection and termination method. The bq2000T and bq2002T use this method of termination. A nickel battery's temperature typically rises at  $>1^{\circ}\text{C}/\text{min}$  when it has been charged to its full capacity, for charge rates  $C/2$  and greater. The charger IC monitors the voltage across the thermistor and terminates the charging when the voltage on the TS pin (temperature) rises the appropriate amount, between measurements. Note that a dynamic system load across the battery does not result in a fast transient temperature response that would give a false  $dT/dt$  termination. The charger current should be set so that the average current into the battery is  $C/3$  or greater ( $I_{\text{battery}} = I_{\text{charger}} - I_{\text{system}}$ ), to insure the proper temperature rise rate when the battery reaches full capacity.
- **Keep batteries isolated from heat sources.** If the ambient temperature (battery temperature) is high (approaching  $40^{\circ}\text{C}$ ), the charge rate may have to be increased to overcome the flattening effect from the high ambient temperature. Consult with the battery manufacturer to obtain the voltage profiles over temperature.
- **Power System From the Input Source** – The circuit shown in Figure 2 and previously discussed also can be used to isolate the battery from the system load.

## IMPORTANT NOTICE

Texas Instruments Incorporated and its subsidiaries (TI) reserve the right to make corrections, modifications, enhancements, improvements, and other changes to its products and services at any time and to discontinue any product or service without notice. Customers should obtain the latest relevant information before placing orders and should verify that such information is current and complete. All products are sold subject to TI's terms and conditions of sale supplied at the time of order acknowledgment.

TI warrants performance of its hardware products to the specifications applicable at the time of sale in accordance with TI's standard warranty. Testing and other quality control techniques are used to the extent TI deems necessary to support this warranty. Except where mandated by government requirements, testing of all parameters of each product is not necessarily performed.

TI assumes no liability for applications assistance or customer product design. Customers are responsible for their products and applications using TI components. To minimize the risks associated with customer products and applications, customers should provide adequate design and operating safeguards.

TI does not warrant or represent that any license, either express or implied, is granted under any TI patent right, copyright, mask work right, or other TI intellectual property right relating to any combination, machine, or process in which TI products or services are used. Information published by TI regarding third-party products or services does not constitute a license from TI to use such products or services or a warranty or endorsement thereof. Use of such information may require a license from a third party under the patents or other intellectual property of the third party, or a license from TI under the patents or other intellectual property of TI.

Reproduction of information in TI data books or data sheets is permissible only if reproduction is without alteration and is accompanied by all associated warranties, conditions, limitations, and notices. Reproduction of this information with alteration is an unfair and deceptive business practice. TI is not responsible or liable for such altered documentation.

Resale of TI products or services with statements different from or beyond the parameters stated by TI for that product or service voids all express and any implied warranties for the associated TI product or service and is an unfair and deceptive business practice. TI is not responsible or liable for any such statements.

Following are URLs where you can obtain information on other Texas Instruments products and application solutions:

<b>Products</b>		<b>Applications</b>	
Amplifiers	<a href="http://amplifier.ti.com">amplifier.ti.com</a>	Audio	<a href="http://www.ti.com/audio">www.ti.com/audio</a>
Data Converters	<a href="http://dataconverter.ti.com">dataconverter.ti.com</a>	Automotive	<a href="http://www.ti.com/automotive">www.ti.com/automotive</a>
DSP	<a href="http://dsp.ti.com">dsp.ti.com</a>	Broadband	<a href="http://www.ti.com/broadband">www.ti.com/broadband</a>
Interface	<a href="http://interface.ti.com">interface.ti.com</a>	Digital Control	<a href="http://www.ti.com/digitalcontrol">www.ti.com/digitalcontrol</a>
Logic	<a href="http://logic.ti.com">logic.ti.com</a>	Military	<a href="http://www.ti.com/military">www.ti.com/military</a>
Power Mgmt	<a href="http://power.ti.com">power.ti.com</a>	Optical Networking	<a href="http://www.ti.com/opticalnetwork">www.ti.com/opticalnetwork</a>
Microcontrollers	<a href="http://microcontroller.ti.com">microcontroller.ti.com</a>	Security	<a href="http://www.ti.com/security">www.ti.com/security</a>
		Telephony	<a href="http://www.ti.com/telephony">www.ti.com/telephony</a>
		Video & Imaging	<a href="http://www.ti.com/video">www.ti.com/video</a>
		Wireless	<a href="http://www.ti.com/wireless">www.ti.com/wireless</a>

Mailing Address: Texas Instruments  
Post Office Box 655303 Dallas, Texas 75265