



NiCd/NiMH Fast-Charge Management IC

Features

- Fast charge of nickel cadmium or nickel-metal hydride batteries
- Direct LED output displays charge status
- Fast-charge termination by $-\Delta V$, maximum voltage, maximum temperature, and maximum time
- Internal band-gap voltage reference
- Selectable pulse-trickle charge rates
- Low-power mode
- 8-pin 300-mil DIP or 150-mil SOIC

General Description

The bq2002C Fast-Charge IC is a low-cost CMOS battery-charge controller providing reliable charge termination for both NiCd and NiMH battery applications. Controlling a current-limited or constant-current supply allows the bq2002C to be the basis for a cost-effective stand-alone or system-integrated charger. The bq2002C integrates fast charge with pulsed-trickle control in a single IC for charging one or more NiCd or NiMH battery cells.

Fast charge is initiated on application of the charging supply or battery replacement. For safety, fast charge is inhibited if the battery temperature and voltage are outside configured limits.

Fast charge is terminated by any of the following:

- Peak voltage detection (PVD)
- Negative delta voltage ($-\Delta V$)
- Maximum voltage
- Maximum temperature
- Maximum time

After fast charge, the bq2002C pulse-trickles the battery per the pre-configured limits. Fast charge may be inhibited using the INH pin. The bq2002C may also be placed in low-standby-power mode to reduce system power consumption.

Pin Connections

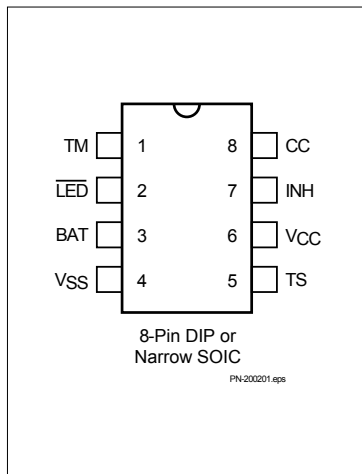

Pin Names

TM	Timer mode select input	TS	Temperature sense input
$\overline{\text{LED}}$	Charging status output	V _{CC}	Supply voltage input
BAT	Battery voltage input	INH	Charge inhibit input
V _{SS}	System ground	CC	Charge control output

bq2002C

Pin Descriptions

TM	Timer mode input
	A three-level input that controls the settings for the fast charge safety timer, voltage termination mode, pulse-trickle, and voltage hold-off time.
LED	Charging output status
	Open-drain output that indicates the charging status.
BAT	Battery input voltage
	The battery voltage sense input. The input to this pin is created by a high-impedance resistor divider network connected between the positive and negative terminals of the battery.
Vss	System ground
TS	Temperature sense input
	Input for an external battery temperature monitoring thermistor.
Vcc	Supply voltage input
	5.0V ±20% power input.
INH	Charge inhibit input
	When high, INH suspends the fast charge in progress. When returned low, the IC resumes operation at the point where initially suspended.

CC Charge control output

An open-drain output used to control the charging current to the battery. CC switching to high impedance (Z) enables charging current to flow, and low to inhibit charging current. CC is modulated to provide pulse trickle.

Functional Description

Figure 2 shows a state diagram and Figure 3 shows a block diagram of the bq2002C.

Battery Voltage and Temperature Measurements

Battery voltage and temperature are monitored for maximum allowable values. The voltage presented on the battery sense input, BAT, should represent a single-cell potential for the battery under charge. A resistor-divider ratio of

$$\frac{RB1}{RB2} = N - 1$$

is recommended to maintain the battery voltage within the valid range, where N is the number of cells, RB1 is the resistor connected to the positive battery terminal, and RB2 is the resistor connected to the negative battery terminal. See Figure 1.

Note: This resistor-divider network input impedance to end-to-end should be at least 200kΩ and less than 1 MΩ.

A ground-referenced negative temperature coefficient thermistor placed near the battery may be used as a low-cost temperature-to-voltage transducer. The temperature sense voltage input at TS is developed using a resistor-thermistor network between VCC and VSS. See Figure 1.

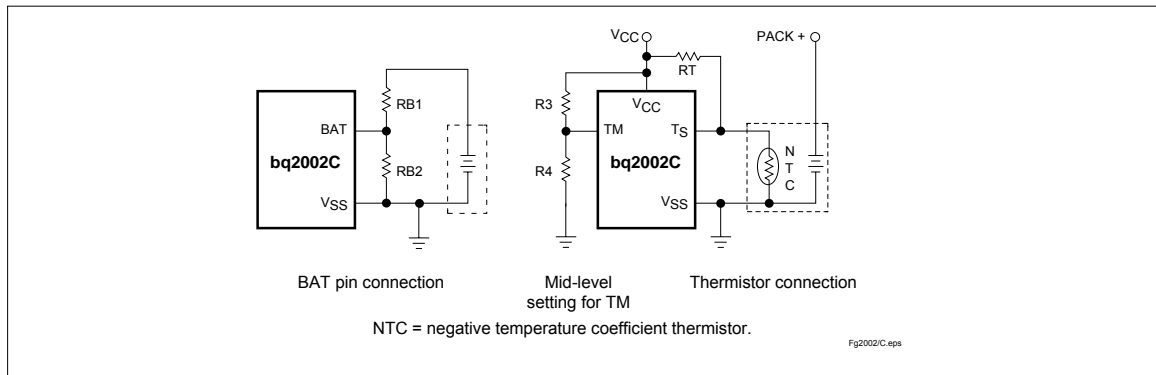

Figure 1. Voltage and Temperature Monitoring and TM Pin Configuration

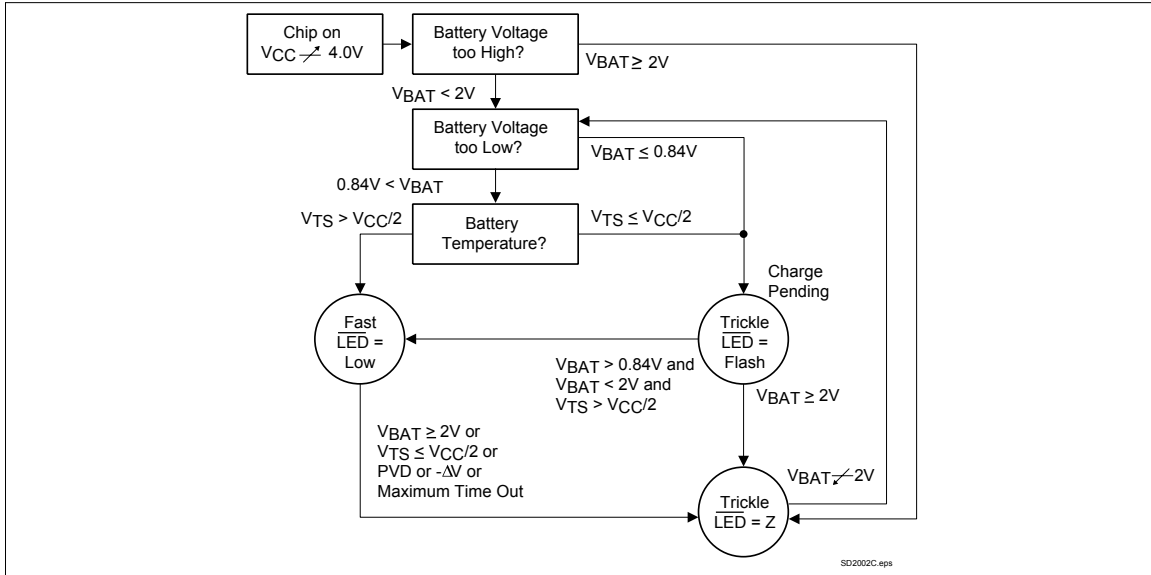

Figure 2. State Diagram

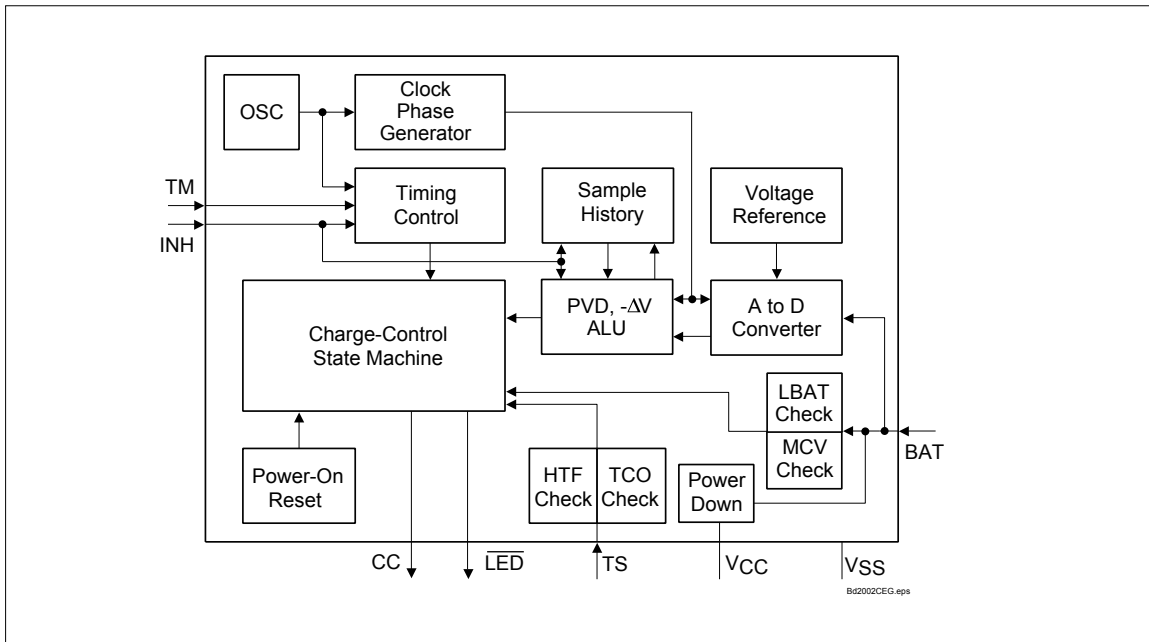

Figure 3. Block Diagram

bq2002C

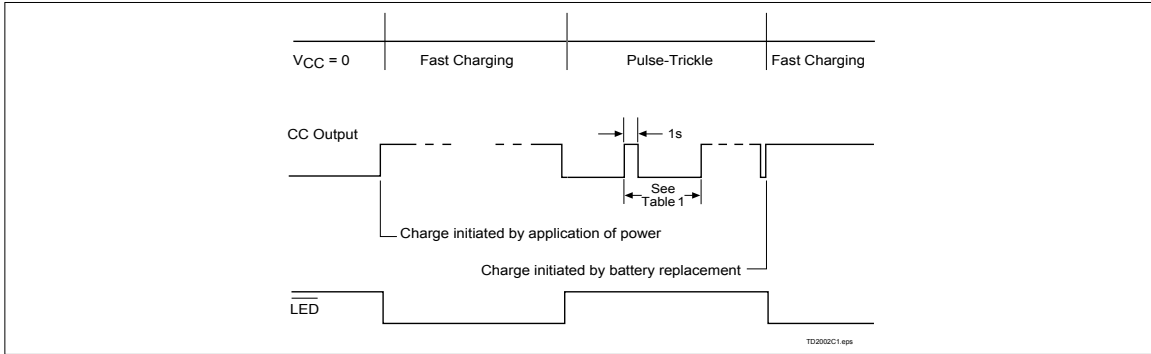

Figure 4. Charge Cycle Phases

Starting A Charge Cycle

Either of two events starts a charge cycle (see Figure 4):

1. Application of power to V_{CC} or
2. Voltage at the BAT pin falling through the maximum cell voltage V_{MCV} where

$$V_{MCV} = 2V \pm 5\%$$

If the battery is within the configured temperature and voltage limits, the IC begins fast charge. The valid battery voltage range is $V_{LBAT} < V_{BAT} < V_{MCV}$, where

$$V_{LBAT} = 0.175 * V_{CC} \pm 20\%$$

The valid temperature range is $V_{TS} > V_{HTF}$ where

$$V_{HTF} = 0.6 * V_{CC} \pm 5\%$$

If $V_{BAT} \leq V_{LBAT}$ or $V_{TS} \leq V_{HTF}$, the IC enters the charge-

pending state. In this state pulse trickle charge is applied to the battery and the LED flashes until the voltage and temperature come into the allowed fast charge range or V_{BAT} rises above V_{MCV} . Anytime $V_{BAT} \geq V_{MCV}$, the IC enters the Charge Complete/Battery Absent state. In this state the LED is off and trickle charge is applied to the battery until the next new charge cycle begins.

Fast charge continues until termination by one or more of the five possible termination conditions:

- Peak voltage detection (PVD)
- Negative delta voltage ($-\Delta V$)
- Maximum voltage
- Maximum temperature
- Maximum time

Table 1. Fast-Charge Safety Time/Hold-Off Table

Corresponding Fast-Charge Rate	TM	Termination	Typical Fast-Charge Time Limits (minutes)	Typical PVD and $-\Delta V$ Hold-Off Time (seconds)	Pulse-Trickle Rate	Pulse-Trickle Pulse Width (ms)	Maximum Synchronized Sampling Period (seconds)
C/2	Mid	PVD	160	300	C/32	73	18.7
1C	Low	PVD	80	150	C/32	37	18.7
2C	High	$-\Delta V$	40	75	C/32	18	9.4

Notes: Typical conditions = 25°C, $V_{CC} = 5.0V$
 Mid = $0.5 * V_{CC} \pm 0.5V$
 Tolerance on all timing is $\pm 12\%$.

PVD and $-\Delta V$ Termination

There are two modes for voltage termination, depending on the state of TM. For $-\Delta V$ (TM = high), if V_{BAT} is lower than any previously measured value by 12mV \pm 3mV, fast charge is terminated. For PVD (TM = low or mid), a decrease of 2.5mV \pm 2.5mV terminates fast charge. The PVD and $-\Delta V$ tests are valid in the range $1V < V_{BAT} < 2V$.

Synchronized Voltage Sampling

Voltage sampling at the BAT pin for PVD and $-\Delta V$ termination may be synchronized to an external stimulus using the INH input. Low-high-low input pulses between 100ns and 3.5ms in width must be applied at the INH pin with a frequency greater than the “maximum synchronized sampling period” set by the state of the TM pin as shown in Table 1. Voltage is sampled on the falling edge of such pulses. If the time between pulses is greater than the synchronizing period, voltage sampling “free-runs” at once every 17 seconds. A sample is taken by averaging together voltage measurements taken 57 μ s apart. The IC takes 32 measurements in PVD mode and 16 measurements in $-\Delta V$ mode. The resulting sample periods (9.17 and 18.18ms, respectively) filter out harmonics centered around 55 and 109Hz. This technique minimizes the effect of any AC line ripple that may feed through the power supply from either 50 or 60Hz AC sources. If the INH input remains high for more than 12ms, the voltage sample history kept by the IC and used for PVD and $-\Delta V$ termination decisions is erased and a new history is started. Such a reset is required when transitioning from free-running to synchronized voltage sampling. The response of the IC to pulses less than 100ns in width or between 3.5ms and 12ms is indeterminate. The tolerance on all timing is \pm 12%.

Voltage Termination Hold-off

A hold-off period occurs at the start of fast charging. During the hold-off time, the PVD and $-\Delta V$ terminations are disabled. This avoids premature termination on the voltage spikes sometimes produced by older batteries when fast-charge current is first applied. Maximum voltage and temperature terminations are not affected by the hold-off period.

Maximum Voltage, Temperature, and Time

Any time the voltage on the BAT pin exceeds the maximum cell voltage, V_{MCV}, fast charge is terminated.

Maximum temperature termination occurs anytime the voltage on the TS pin falls below the temperature cut-off threshold V_{TCO}, where

$$V_{TCO} = 0.5 \times V_{CC} \pm 5\%.$$

Maximum charge time is configured using the TM pin. Time settings are available for corresponding charge rates of C/2, 1C, and 2C. Maximum time-out termination is enforced on the fast-charge phase. There is no time limit on the trickle-charge phase.

Pulse-Trickle Charge

Pulse-trickle is used to compensate for self-discharge while the battery is idle in the charger. The battery is pulse-trickle charged by driving the CC pin active once per second for the period specified in Table 1. This results in a trickle rate of C/32.

TM Pin

The TM pin is a three-level pin used to select the charge timer, voltage termination mode, trickle rate, and voltage hold-off period options. Table 1 describes the states selected by the TM pin. The mid-level selection input is developed by a resistor divider between V_{CC} and ground that fixes the voltage on TM at $V_{CC}/2 \pm 0.5V$. See Figure 4.

Charge Status Indication

A fast charge in progress is uniquely indicated when the \overline{LED} pin goes low. In the charge pending state, the \overline{LED} pin is driven low for 500ms, then to high-Z for 500ms. The \overline{LED} pin is driven to the high-Z state for all other conditions. Figure 2 outlines the state of the \overline{LED} pin during charge.

Charge Inhibit

Fast charge may be inhibited by using the INH pin. When high, INH suspends all fast charge activity and the internal charge timer. INH freezes the current state of \overline{LED} until inhibit is removed. Temperature monitoring is not affected by the INH pin. During charge inhibit, the bq2002C continues to pulse-trickle charge the battery per the TM selection. When INH returns low, charge control and the charge timer resume from the point where INH became active.

Low-Power Mode

The IC enters a low-power state when V_{BAT} is driven above the power-down threshold (V_{PD}) where:

$$V_{PD} = V_{CC} - (1V \pm 0.5V)$$

Both the CC pin and the \overline{LED} are driven to the high-Z state. The operating current is reduced to less than 1 μ A in this mode. When V_{BAT} returns to a value below V_{PD}, the IC pulse-trickle charges until the next new charge cycle begins.

bq2002C

bq2002C

Absolute Maximum Ratings

Symbol	Parameter	Minimum	Maximum	Unit	Notes
V _{CC}	V _{CC} relative to V _{SS}	-0.3	+7.0	V	
V _T	DC voltage applied on any pin excluding V _{CC} relative to V _{SS}	-0.3	+7.0	V	
T _{OPR}	Operating ambient temperature	0	+70	°C	Commercial
T _{STG}	Storage temperature	-40	+85	°C	
T _{SOLDER}	Soldering temperature	-	+260	°C	10 sec max.
T _{BIAS}	Temperature under bias	-40	+85	°C	

Note: Permanent device damage may occur if **Absolute Maximum Ratings** are exceeded. Functional operation should be limited to the Recommended DC Operating Conditions detailed in this data sheet. Exposure to conditions beyond the operational limits for extended periods of time may affect device reliability.

DC Thresholds (T_A = 0 to 70°C; V_{CC} ±20%)

Symbol	Parameter	Rating	Tolerance	Unit	Notes
V _{TCO}	Temperature cutoff	0.5 * V _{CC}	±5%	V	V _{TS} ≤ V _{TCO} inhibits/terminates fast charge
V _{HTF}	High-temperature fault	0.6 * V _{CC}	±5%	V	V _{TS} ≤ V _{HTF} inhibits fast charge start
V _{MCV}	Maximum cell voltage	2	±5%	V	V _{BAT} ≥ V _{MCV} inhibits/terminates fast charge
V _{LBAT}	Minimum cell voltage	0.175 * V _{CC}	±20%	V	V _{BAT} ≤ V _{LBAT} inhibits fast charge
-ΔV	BAT input change for -ΔV detection	-12	±3	mV	
PVD	BAT input change for PVD detection	-2.5	±2.5	mV	

Recommended DC Operating Conditions ($T_A = 0$ to 70°C)

Symbol	Condition	Minimum	Typical	Maximum	Unit	Notes
V _{CC}	Supply voltage	4.0	5.0	6.0	V	
V _{DET}	-ΔV, PVD detect voltage	1	-	2	V	
V _{BAT}	Battery input	0	-	V _{CC}	V	
V _{TS}	Thermistor input	0.5	-	V _{CC}	V	V _{TS} < 0.5V prohibited
V _{IH}	Logic input high	0.5	-	-	V	INH
	Logic input high	V _{CC} - 0.5	-	-	V	TM
V _{IM}	Logic input mid	$\frac{V_{CC}}{2} - 0.5$	-	$\frac{V_{CC}}{2} + 0.5$	V	TM
V _{IL}	Logic input low	-	-	0.1	V	INH
	Logic input low	-	-	0.5	V	TM
V _{OL}	Logic output low	-	-	0.8	V	$\overline{\text{LED}}$, CC, I _{OL} = 10mA
V _{PD}	Power down	V _{CC} - 1.5	-	V _{CC} - 0.5	V	V _{BAT} ≥ V _{PD} max. powers down bq2002C; V _{BAT} < V _{PD} min. = normal operation.
I _{CC}	Supply current	-	-	500	μA	Outputs unloaded, V _{CC} = 5.1V
I _{SB}	Standby current	-	-	1	μA	V _{CC} = 5.1V, V _{BAT} = V _{PD}
I _{OL}	$\overline{\text{LED}}$, CC sink	10	-	-	mA	@V _{OL} = V _{SS} + 0.8V
I _L	Input leakage	-	-	±1	μA	INH, CC, V = V _{SS} to V _{CC}
I _{OZ}	Output leakage in high-Z state	-5	-	-	μA	$\overline{\text{LED}}$, CC

Note: All voltages relative to V_{SS}.

bq2002C

Impedance

Symbol	Parameter	Minimum	Typical	Maximum	Unit
R _{BAT}	Battery input impedance	50	-	-	MΩ
R _{TS}	TS input impedance	50	-	-	MΩ

Timing (T_A = 0 to +70°C; V_{CC} ±10%)

Symbol	Parameter	Minimum	Typical	Maximum	Unit	Notes
d _{FCV}	Time base variation	-12	-	12	%	

Note: Typical is at T_A = 25°C, V_{CC} = 5.0V.

8-Pin DIP (PN)

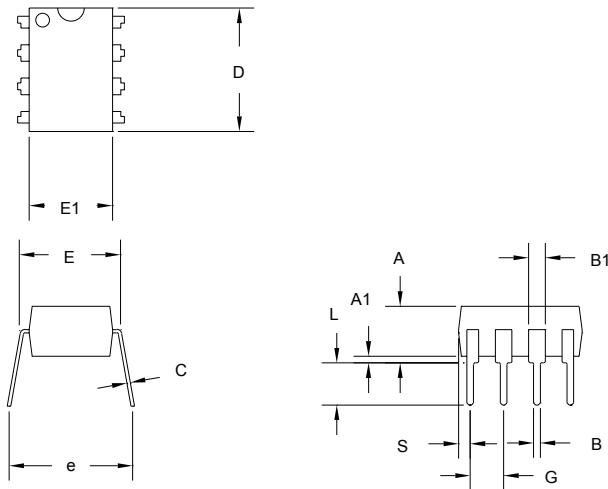

8-Pin PN (0.300" DIP)

Dimension	Inches		Millimeters	
	Min.	Max.	Min.	Max.
A	0.160	0.180	4.06	4.57
A1	0.015	0.040	0.38	1.02
B	0.015	0.022	0.38	0.56
B1	0.055	0.065	1.40	1.65
C	0.008	0.013	0.20	0.33
D	0.350	0.380	8.89	9.65
E	0.300	0.325	7.62	8.26
E1	0.230	0.280	5.84	7.11
e	0.300	0.370	7.62	9.40
G	0.090	0.110	2.29	2.79
L	0.115	0.150	2.92	3.81
S	0.020	0.040	0.51	1.02

bq2002C

8-Pin SOIC Narrow (SN)

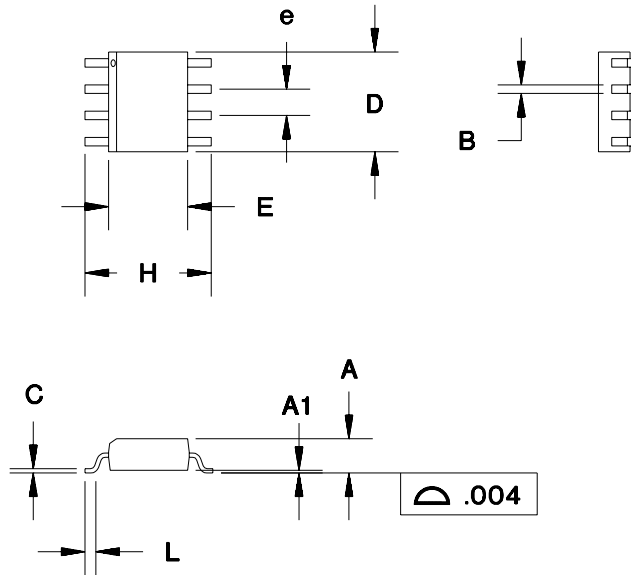

8-Pin SN (0.150" SOIC)

Dimension	Inches		Millimeters	
	Min.	Max.	Min.	Max.
A	0.060	0.070	1.52	1.78
A1	0.004	0.010	0.10	0.25
B	0.013	0.020	0.33	0.51
C	0.007	0.010	0.18	0.25
D	0.185	0.200	4.70	5.08
E	0.150	0.160	3.81	4.06
e	0.045	0.055	1.14	1.40
H	0.225	0.245	5.72	6.22
L	0.015	0.035	0.38	0.89

Data Sheet Revision History

Change No.	Page No.	Description
1	All	Revised format and outline of this data sheet
2	5	Removed "top-off"

Note: Change 1 = Sept. 1997 B changes from Dec. 1995.

Note: Change 2 = July 2011

Ordering Information

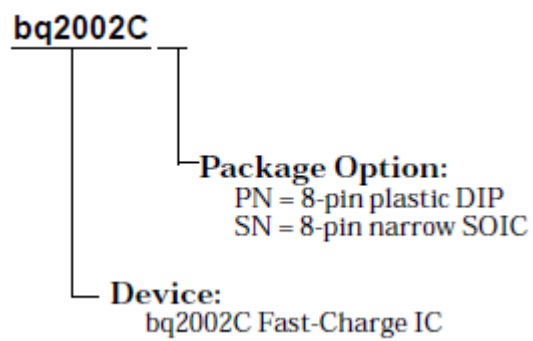

PACKAGING INFORMATION

Orderable Device	Status ⁽¹⁾	Package Type	Package Drawing	Pins	Package Qty	Eco Plan ⁽²⁾	Lead/ Ball Finish	MSL Peak Temp ⁽³⁾	Samples (Requires Login)
BQ2002CPN	ACTIVE	PDIP	P	8	50	Pb-Free (RoHS)	CU NIPDAU	N / A for Pkg Type	
BQ2002CPNE4	ACTIVE	PDIP	P	8	50	Pb-Free (RoHS)	CU NIPDAU	N / A for Pkg Type	
BQ2002CSN	ACTIVE	SOIC	D	8	75	Green (RoHS & no Sb/Br)	CU NIPDAU	Level-1-260C-UNLIM	
BQ2002CSNG4	ACTIVE	SOIC	D	8	75	Green (RoHS & no Sb/Br)	CU NIPDAU	Level-1-260C-UNLIM	
BQ2002CSNTR	ACTIVE	SOIC	D	8	2500	Green (RoHS & no Sb/Br)	CU NIPDAU	Level-1-260C-UNLIM	
BQ2002CSNTRG4	ACTIVE	SOIC	D	8	2500	Green (RoHS & no Sb/Br)	CU NIPDAU	Level-1-260C-UNLIM	

⁽¹⁾ The marketing status values are defined as follows:

ACTIVE: Product device recommended for new designs.

LIFEBUY: TI has announced that the device will be discontinued, and a lifetime-buy period is in effect.

NRND: Not recommended for new designs. Device is in production to support existing customers, but TI does not recommend using this part in a new design.

PREVIEW: Device has been announced but is not in production. Samples may or may not be available.

OBSOLETE: TI has discontinued the production of the device.

⁽²⁾ Eco Plan - The planned eco-friendly classification: Pb-Free (RoHS), Pb-Free (RoHS Exempt), or Green (RoHS & no Sb/Br) - please check <http://www.ti.com/productcontent> for the latest availability information and additional product content details.

TBD: The Pb-Free/Green conversion plan has not been defined.

Pb-Free (RoHS): TI's terms "Lead-Free" or "Pb-Free" mean semiconductor products that are compatible with the current RoHS requirements for all 6 substances, including the requirement that lead not exceed 0.1% by weight in homogeneous materials. Where designed to be soldered at high temperatures, TI Pb-Free products are suitable for use in specified lead-free processes.

Pb-Free (RoHS Exempt): This component has a RoHS exemption for either 1) lead-based flip-chip solder bumps used between the die and package, or 2) lead-based die adhesive used between the die and leadframe. The component is otherwise considered Pb-Free (RoHS compatible) as defined above.

Green (RoHS & no Sb/Br): TI defines "Green" to mean Pb-Free (RoHS compatible), and free of Bromine (Br) and Antimony (Sb) based flame retardants (Br or Sb do not exceed 0.1% by weight in homogeneous material)

⁽³⁾ MSL, Peak Temp. -- The Moisture Sensitivity Level rating according to the JEDEC industry standard classifications, and peak solder temperature.

Important Information and Disclaimer: The information provided on this page represents TI's knowledge and belief as of the date that it is provided. TI bases its knowledge and belief on information provided by third parties, and makes no representation or warranty as to the accuracy of such information. Efforts are underway to better integrate information from third parties. TI has taken and continues to take reasonable steps to provide representative and accurate information but may not have conducted destructive testing or chemical analysis on incoming materials and chemicals. TI and TI suppliers consider certain information to be proprietary, and thus CAS numbers and other limited information may not be available for release.

In no event shall TI's liability arising out of such information exceed the total purchase price of the TI part(s) at issue in this document sold by TI to Customer on an annual basis.

TAPE AND REEL INFORMATION

QUADRANT ASSIGNMENTS FOR PIN 1 ORIENTATION IN TAPE

*All dimensions are nominal

Device	Package Type	Package Drawing	Pins	SPQ	Reel Diameter (mm)	Reel Width W1 (mm)	A0 (mm)	B0 (mm)	K0 (mm)	P1 (mm)	W (mm)	Pin1 Quadrant
BQ2002CSNTR	SOIC	D	8	2500	330.0	12.4	6.4	5.2	2.1	8.0	12.0	Q1

TAPE AND REEL BOX DIMENSIONS



*All dimensions are nominal

Device	Package Type	Package Drawing	Pins	SPQ	Length (mm)	Width (mm)	Height (mm)
BQ2002CSNTR	SOIC	D	8	2500	340.5	338.1	20.6

IMPORTANT NOTICE

Texas Instruments Incorporated and its subsidiaries (TI) reserve the right to make corrections, modifications, enhancements, improvements, and other changes to its products and services at any time and to discontinue any product or service without notice. Customers should obtain the latest relevant information before placing orders and should verify that such information is current and complete. All products are sold subject to TI's terms and conditions of sale supplied at the time of order acknowledgment.

TI warrants performance of its hardware products to the specifications applicable at the time of sale in accordance with TI's standard warranty. Testing and other quality control techniques are used to the extent TI deems necessary to support this warranty. Except where mandated by government requirements, testing of all parameters of each product is not necessarily performed.

TI assumes no liability for applications assistance or customer product design. Customers are responsible for their products and applications using TI components. To minimize the risks associated with customer products and applications, customers should provide adequate design and operating safeguards.

TI does not warrant or represent that any license, either express or implied, is granted under any TI patent right, copyright, mask work right, or other TI intellectual property right relating to any combination, machine, or process in which TI products or services are used. Information published by TI regarding third-party products or services does not constitute a license from TI to use such products or services or a warranty or endorsement thereof. Use of such information may require a license from a third party under the patents or other intellectual property of the third party, or a license from TI under the patents or other intellectual property of TI.

Reproduction of TI information in TI data books or data sheets is permissible only if reproduction is without alteration and is accompanied by all associated warranties, conditions, limitations, and notices. Reproduction of this information with alteration is an unfair and deceptive business practice. TI is not responsible or liable for such altered documentation. Information of third parties may be subject to additional restrictions.

Resale of TI products or services with statements different from or beyond the parameters stated by TI for that product or service voids all express and any implied warranties for the associated TI product or service and is an unfair and deceptive business practice. TI is not responsible or liable for any such statements.

TI products are not authorized for use in safety-critical applications (such as life support) where a failure of the TI product would reasonably be expected to cause severe personal injury or death, unless officers of the parties have executed an agreement specifically governing such use. Buyers represent that they have all necessary expertise in the safety and regulatory ramifications of their applications, and acknowledge and agree that they are solely responsible for all legal, regulatory and safety-related requirements concerning their products and any use of TI products in such safety-critical applications, notwithstanding any applications-related information or support that may be provided by TI. Further, Buyers must fully indemnify TI and its representatives against any damages arising out of the use of TI products in such safety-critical applications.

TI products are neither designed nor intended for use in military/aerospace applications or environments unless the TI products are specifically designated by TI as military-grade or "enhanced plastic." Only products designated by TI as military-grade meet military specifications. Buyers acknowledge and agree that any such use of TI products which TI has not designated as military-grade is solely at the Buyer's risk, and that they are solely responsible for compliance with all legal and regulatory requirements in connection with such use.

TI products are neither designed nor intended for use in automotive applications or environments unless the specific TI products are designated by TI as compliant with ISO/TS 16949 requirements. Buyers acknowledge and agree that, if they use any non-designated products in automotive applications, TI will not be responsible for any failure to meet such requirements.

Following are URLs where you can obtain information on other Texas Instruments products and application solutions:

Products

Audio	www.ti.com/audio
Amplifiers	amplifier.ti.com
Data Converters	dataconverter.ti.com
DLP® Products	www.dlp.com
DSP	dsp.ti.com
Clocks and Timers	www.ti.com/clocks
Interface	interface.ti.com
Logic	logic.ti.com
Power Mgmt	power.ti.com
Microcontrollers	microcontroller.ti.com
RFID	www.ti-rfid.com
RF/IF and ZigBee® Solutions	www.ti.com/lprf

Applications

Communications and Telecom	www.ti.com/communications
Computers and Peripherals	www.ti.com/computers
Consumer Electronics	www.ti.com/consumer-apps
Energy and Lighting	www.ti.com/energy
Industrial	www.ti.com/industrial
Medical	www.ti.com/medical
Security	www.ti.com/security
Space, Avionics and Defense	www.ti.com/space-avionics-defense
Transportation and Automotive	www.ti.com/automotive
Video and Imaging	www.ti.com/video
Wireless	www.ti.com/wireless-apps

TI E2E Community Home Page

e2e.ti.com

Mailing Address: Texas Instruments, Post Office Box 655303, Dallas, Texas 75265
Copyright © 2011, Texas Instruments Incorporated