

Programmable Multi-Chemistry Fast-Charge Management IC

Features

- Safe management of fast charge for NiCd, NiMH, or Li-Ion battery packs
- High-frequency switching controller for efficient and simple charger design
- Pre-charge qualification for detecting shorted, damaged, or overheated cells
- Fast-charge termination by peak voltage (PVD), minimum current (Li-Ion), maximum temperature, and maximum charge time
- Selectable top-off mode for achieving maximum capacity in NiMH batteries
- Programmable trickle-charge mode for reviving deeply discharged batteries and for post-charge maintenance
- Built-in battery removal and insertion detection
- Sleep mode for low power consumption

General Description

The bq2000 is a programmable, monolithic IC for fast-charge management of nickel cadmium (NiCd), nickel metal-hydride (NiMH), or lithium-ion (Li-Ion) batteries in single- or multi-chemistry applications. The bq2000 detects the battery chemistry and proceeds with the optimal charging and termination algorithms. This process eliminates undesirable undercharged or overcharged conditions and allows accurate and safe termination of fast charge.

Depending on the chemistry, the bq2000 provides a number of charge termination criteria:

- Peak voltage, PVD (for NiCd and NiMH)
- Minimum charging current (f or Li-Ion)
- Maximum temperature
- Maximum charge time

For safety, the bq2000 inhibits fast charge until the battery voltage and temperature are within user-defined limits. If the battery voltage is below the low-voltage threshold, the bq2000 uses trickle-charge to condition the battery. For NiMH batteries, the bq2000 provides an optional top-off charge to maximize the battery capacity.

The integrated high-frequency comparator allows the bq2000 to be the basis for a complete, high-efficiency power-conversion circuit for both nickel-based and lithium-based chemistries.

Pin Connections

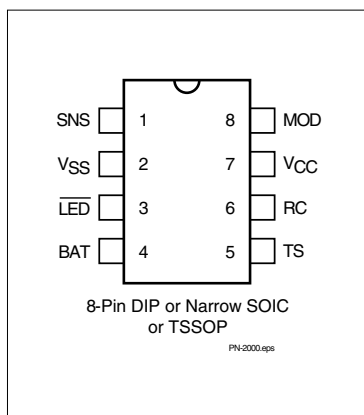

Pin Names

SNS	Current-sense input	TS	Temperature-sense input
VSS	System ground	RC	Timer-program input
$\overline{\text{LED}}$	Charge-status output	VCC	Supply-voltage input
BAT	Battery-voltage input	MOD	Modulation-control output

bq2000

Pin Descriptions

SNS **Current-sense input**

Enables the bq2000 to sense the battery current via the voltage developed on this pin by an external sense-resistor connected in series with the battery pack

Vss **System Ground**

LED **Charge-status output**

Open-drain output that indicates the charging status by turning on, turning off, or flashing an external LED

BAT **Battery-voltage input**

Battery-voltage sense input. A simple resistive divider, across the battery terminals, generates this input.

TS **Temperature-sense input**

Input for an external battery-temperature monitoring circuit. An external resistive divider network with a negative temperature-coefficient thermistor sets the lower and upper temperature thresholds.

RC **Timer-program input**

RC input used to program the maximum charge-time, hold-off period, and trickle rate during the charge cycle, and to disable or enable top-off charge

VCC **Supply-voltage input**

MOD **Modulation-control output**

Push-pull output that controls the charging current to the battery. MOD switches high to enable charging current to flow and low to inhibit charging-current flow.

Functional Description

The bq2000 is a versatile, multi-chemistry battery-charge control device. See Figure 1 for a functional block diagram and Figure 2 for a state diagram.

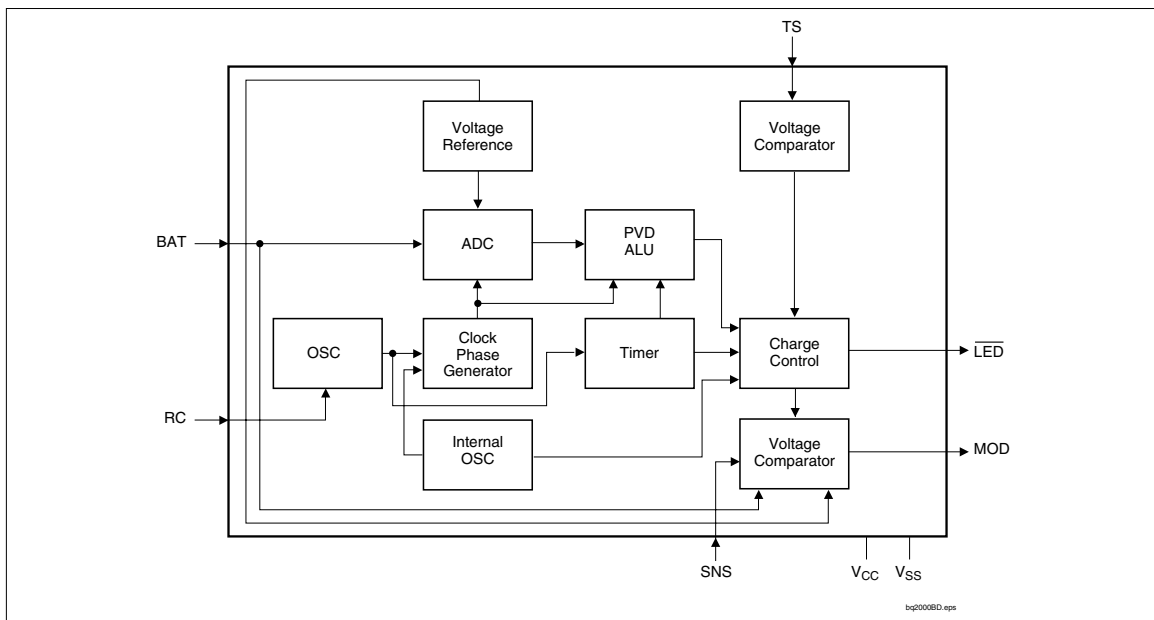

Figure 1. Functional Block Diagram

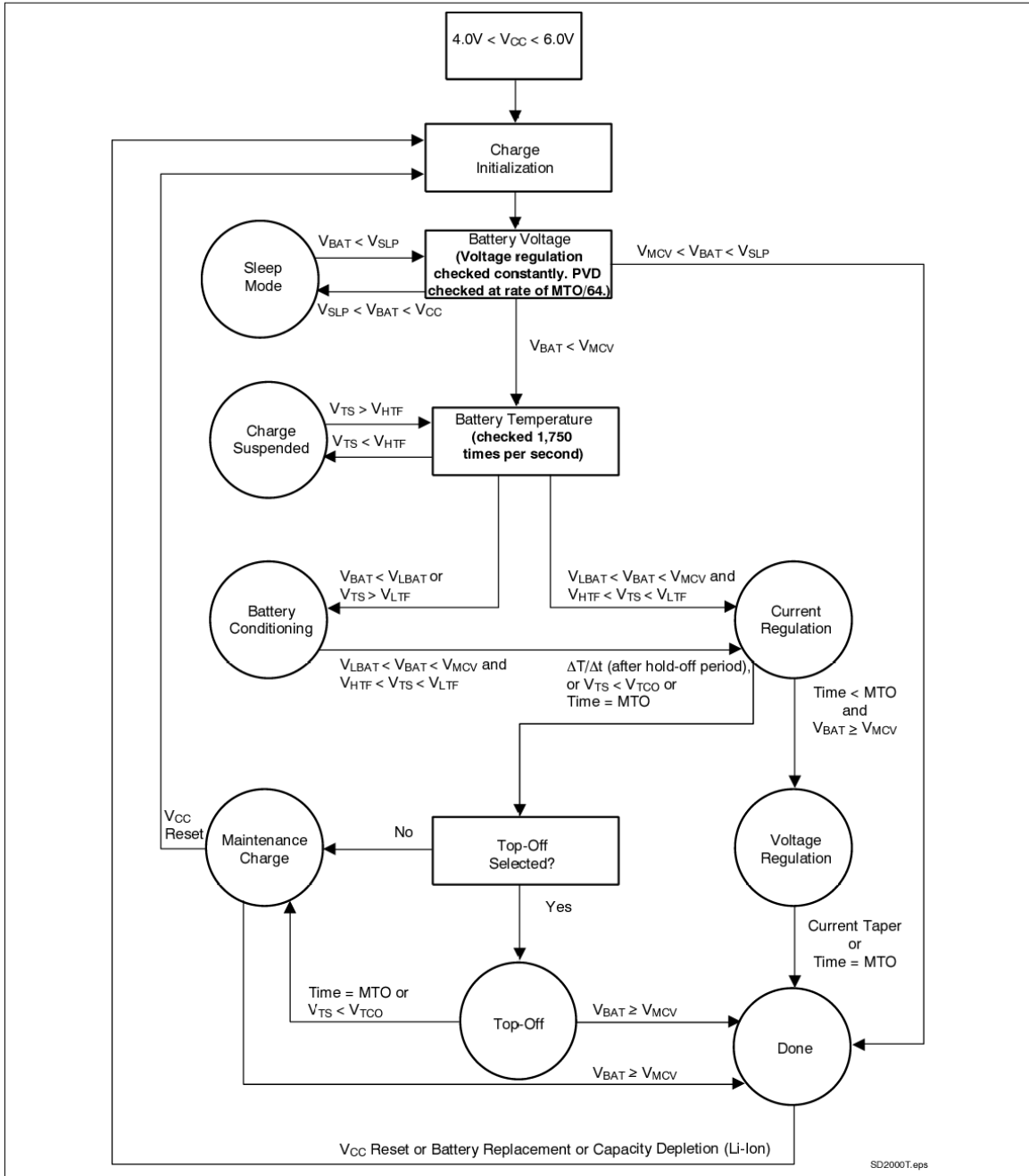

Figure 2. State Diagram

bq2000

Initiation and Charge Qualification

The bq2000 initiates a charge cycle when it detects

- Application of power to V_{CC}
- Battery replacement
- Exit from sleep mode
- Capacity depletion (Li-Ion only)

Immediately following initiation, the IC enters a charge-qualification mode. The bq2000 charge qualification is based on battery voltage and temperature. If voltage on pin BAT is less than the internal threshold, V_{LBAT} , the bq2000 enters the charge-pending state. This condition indicates the possibility of a defective or shorted battery pack. In an attempt to revive a fully depleted pack, the bq2000 enables the MOD pin to trickle-charge at a rate of once every 1.0s. As explained in the section "Top-Off and Pulse-Trickle Charge," the trickle pulse-width is user-selectable and is set by the value of the resistance connected to pin RC.

During this period, the \overline{LED} pin blinks at a 1Hz rate, indicating the pending status of the charger.

Similarly, the bq2000 suspends fast charge if the battery temperature is outside the V_{LTF} to V_{HTF} range. (See Table 4.) For safety reasons, however, it disables the pulse trickle, in the case of a battery over-temperature condition (i.e., $V_{TS} < V_{HTF}$). Fast charge begins when the battery temperature and voltage are valid.

Battery Chemistry

The bq2000 detects the battery chemistry by monitoring the battery-voltage profile during the initial stage of the fast charge. If the voltage on BAT input rises to the internal V_{MCV} reference, the IC assumes a Li-Ion battery. Otherwise the bq2000 assumes NiCd/NiMH chemistry.

As shown in Figure 6, a resistor voltage-divider between the battery pack's positive terminal and V_{SS} scales the battery voltage measured at pin BAT. In a mixed-chemistry design, a common voltage-divider is used as long as the maximum charge voltage of the nickel-based pack is below that of the Li-Ion pack. Otherwise, different scaling is required.

Once the chemistry is determined, the bq2000 completes the fast charge with the appropriate charge algorithm (Table 1). The user can customize the algorithm by programming the device using an external resistor and a capacitor connected to the RC pin, as discussed in later sections.

NiCd and NiMH Batteries

Following qualification, the bq2000 fast-charges NiCd or NiMH batteries using a current-limited algorithm. During the fast-charge period, it monitors charge time, temperature, and voltage for adherence to the termination criteria. This monitoring is further explained in later sections. Following fast charge, the battery is topped off, if top-off is selected. The charging cycle ends with a trickle maintenance-charge that continues as long as the voltage on pin BAT remains below V_{MCV} .

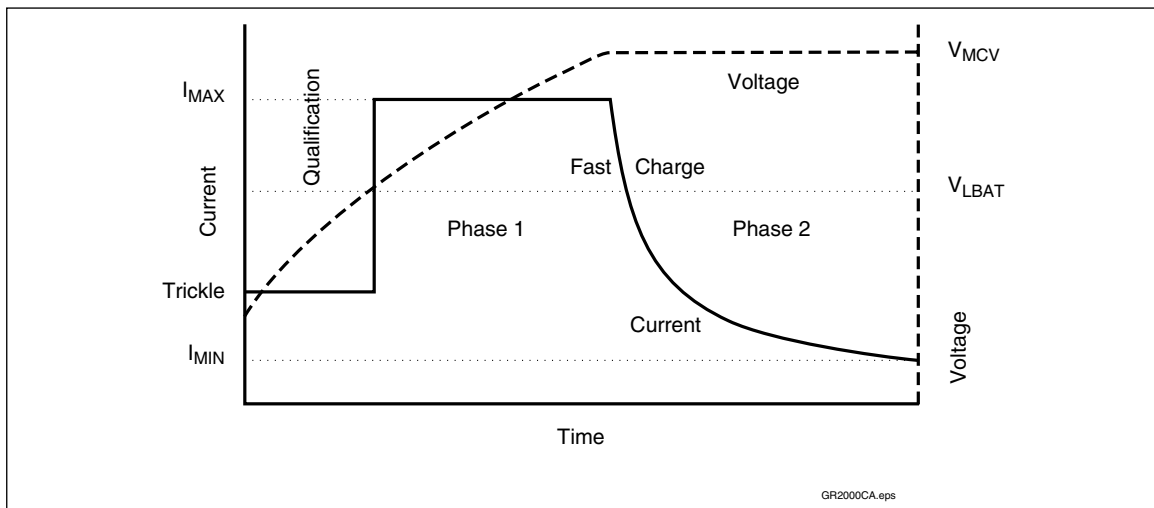

Figure 3. Lithium-Ion Charge Algorithm

Table 1. Charge Algorithm

Battery Chemistry	Charge Algorithm
NiCd or NiMH	<ol style="list-style-type: none"> 1. Charge qualification 2. Trickle charge, if required 3. Fast charge (constant current) 4. Charge termination (peak voltage, maximum charge time) 5. Top-off (optional) 6. Trickle charge
Li-Ion	<ol style="list-style-type: none"> 1. Charge qualification 2. Trickle charge, if required 3. Two-step fast charge (constant current followed by constant voltage) 4. Charge termination (minimum current, maximum charge time)

Lithium-Ion Batteries

The bq2000 uses a two-phase fast-charge algorithm for Li-Ion batteries (Figure 3). In phase one, the bq2000 regulates constant current until V_{BAT} rises to V_{MCV} . The bq2000 then moves to phase two, regulates the battery with constant voltage of V_{MCV} , and terminates when the charging current falls below the I_{MIN} threshold. A new charge cycle is started if the cell voltage falls below the V_{RCH} threshold.

During the current-regulation phase, the bq2000 monitors charge time, battery temperature, and battery voltage for adherence to the termination criteria. During the final constant-voltage stage, in addition to the charge time and temperature, it monitors the charge current as a termination criterion. There is no post-charge maintenance mode for Li-Ion batteries.

Charge Termination

Maximum Charge Time (NiCd, NiMH, and Li-Ion)

The bq2000 sets the maximum charge-time through pin RC. With the proper selection of external resistor and capacitor, various time-out values may be achieved. Figure 4 shows a typical connection.

The following equation shows the relationship between the R_{MTO} and C_{MTO} values and the maximum charge time (MTO) for the bq2000:

$$MTO = R_{MTO} * C_{MTO} * 35,988$$

MTO is measured in minutes, R_{MTO} in ohms, and C_{MTO} in farads. (**Note:** R_{MTO} and C_{MTO} values also determine other features of the device. See Tables 2 and 3 for details.)

For Li-Ion cells, the bq2000 resets the MTO when the battery reaches the constant-voltage phase of the

charge. This feature provides the additional charge time required for Li-Ion cells.

Maximum Temperature (NiCd, NiMH, Li-Ion)

A negative-coefficient thermistor, referenced to V_{SS} and placed in thermal contact with the battery, may be used as a temperature-sensing device. Figure 5 shows a typical temperature-sensing circuit.

During fast charge, the bq2000 compares the battery temperature to an internal high-temperature cutoff threshold, V_{TCO} . As shown in Table 4, high-temperature termination occurs when voltage at pin TS is less than this threshold.

Peak Voltage (NiCd, NiMH)

The bq2000 uses a peak-voltage detection (PVD) scheme to terminate fast charge for NiCd and NiMH batteries. The bq2000 continuously samples the voltage on the BAT pin, representing the battery voltage, and triggers the peak detection feature if this value falls below the maximum sampled value by as much as 3.8mV (PVD). As shown in Figure 6, a resistor voltage-divider between the battery pack's positive terminal and V_{SS} scales the battery voltage measured at pin BAT.

For Li-Ion battery packs, the resistor values R_{B1} and R_{B2} are calculated by the following equation:

$$\frac{R_{B1}}{R_{B2}} = \left(N * \frac{V_{CELL}}{V_{MCV}} \right) - 1$$

where N is the number of cells in series and V_{CELL} is the manufacturer-specified charging voltage. The end-to-end input impedance of this resistive divider network should be at least 200k Ω and no more than 1M Ω .

A NiCd or NiMH battery pack consisting of N series-cells may benefit by the selection of the R_{B1} value to be N-1 times larger than the R_{B2} value.

In a mixed-chemistry design, a common voltage-divider is used as long as the maximum charge voltage of the

bq2000

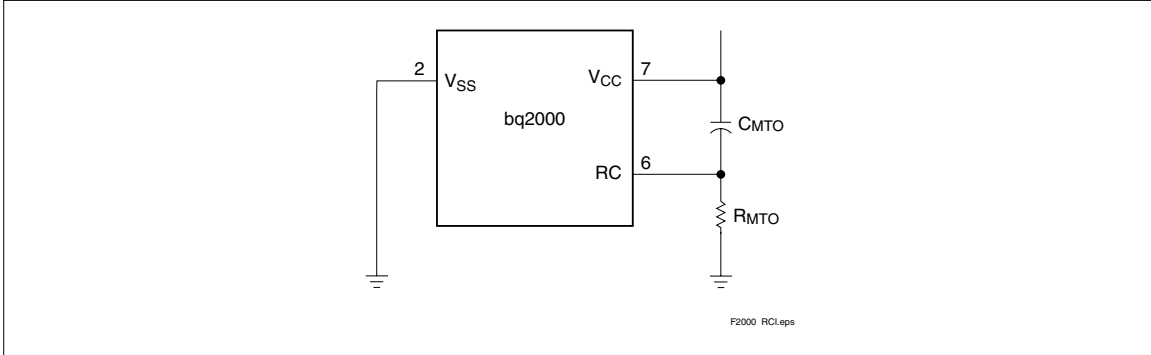

Figure 4. Typical Connection for the RC Input

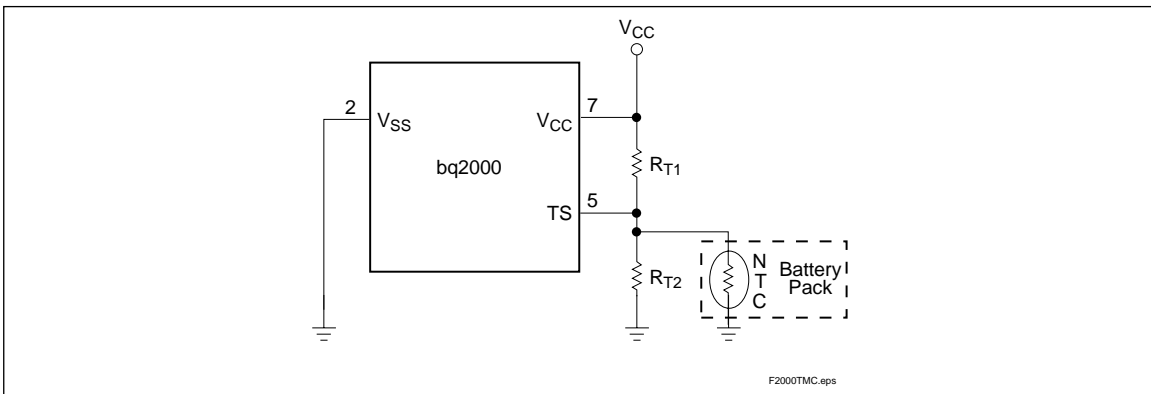

Figure 5. Temperature Monitoring Configuration

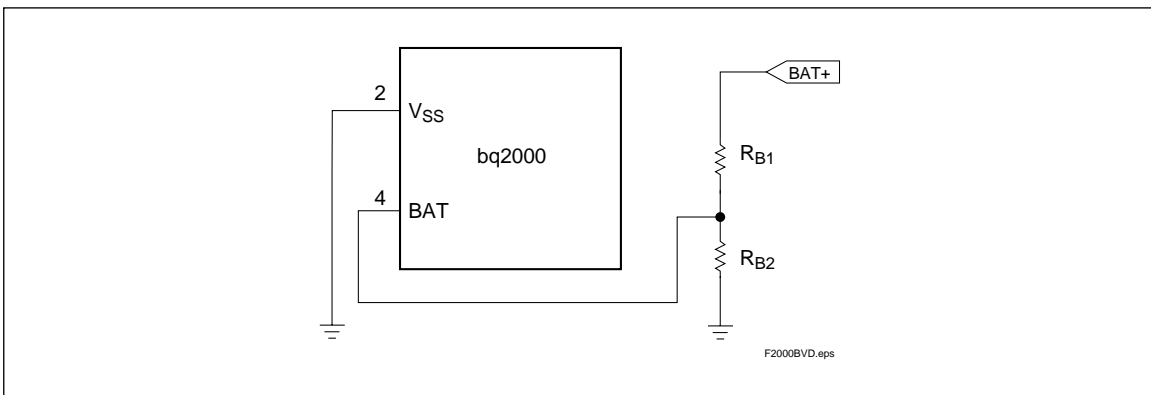

Figure 6. Battery Voltage Divider

nickel-based pack is below that of the Li-Ion pack. Otherwise, different scaling is required.

Minimum Current (Li-Ion Only)

The bq2000 monitors the charging current during the voltage-regulation phase of Li-Ion batteries. Fast charge is terminated when the current is tapered off to 14% of the maximum charging current.

Initial Hold-Off Period

The values of the external resistor and capacitor connected to pin RC set the initial hold-off period. During this period, the bq2000 avoids early termination due to an initial rise in the battery voltage by disabling the peak voltage-detection feature. This period is fixed at the programmed value of the maximum charge time divided by 32.

$$\text{hold-off period} = \frac{\text{maximum time - out}}{32}$$

Top-Off and Pulse-Trickle Charge

An optional top-off charge is available for NiCd or NiMH batteries. Top-off may be desirable on batteries that have a tendency to terminate charge before reaching full capacity. To enable this option, the capacitance value of C_{MTO} connected to pin RC (Figure 4) should be greater than 0.13μF, and the value of the resistor connected to this pin should be less than 15kΩ. To disable top-off, the capacitance value should be less than 0.07μF. The tolerance of the capacitor needs to be taken into account in component selection.

Once enabled, the top-off is performed over a period equal to the maximum charge time at a rate of 1/16 that of fast charge.

Following top-off, the bq2000 trickle-charges the battery by enabling the MOD to charge at a rate of once every 1.0 second. The trickle pulse-width is user-selectable and is set by the value of the resistor R_{MTO}, connected to pin RC. Figure 7 shows the relationship between the trickle pulse-width and the value of R_{MTO}. The typical tolerance of the pulsewidth below 150kΩ is ±10%.

During top-off and trickle-charge, the bq2000 monitors battery voltage and temperature. These charging functions are suspended if the battery voltage rises above the maximum cell voltage (V_{MCV}) or if the temperature exceeds the high-temperature fault threshold (V_{HTF}).

Charge Current Control

The bq2000 controls the charge current through the MOD output pin. The current-control circuit supports a switching-current regulator with frequencies up to 500kHz. The bq2000 monitors charge current at the SNS input by the voltage drop across a sense-resistor, R_{SNS}, in series with the battery pack. See Figure 9 for a typical current-sensing circuit. R_{SNS} is sized to provide the desired fast-charge current (I_{MAX}):

$$I_{MAX} = \frac{0.05}{R_{SNS}}$$

If the voltage at the SNS pin is greater than V_{SNSHI} or less than V_{SNSLO}, the bq2000 switches the MOD output high to pass charge current to the battery. When the

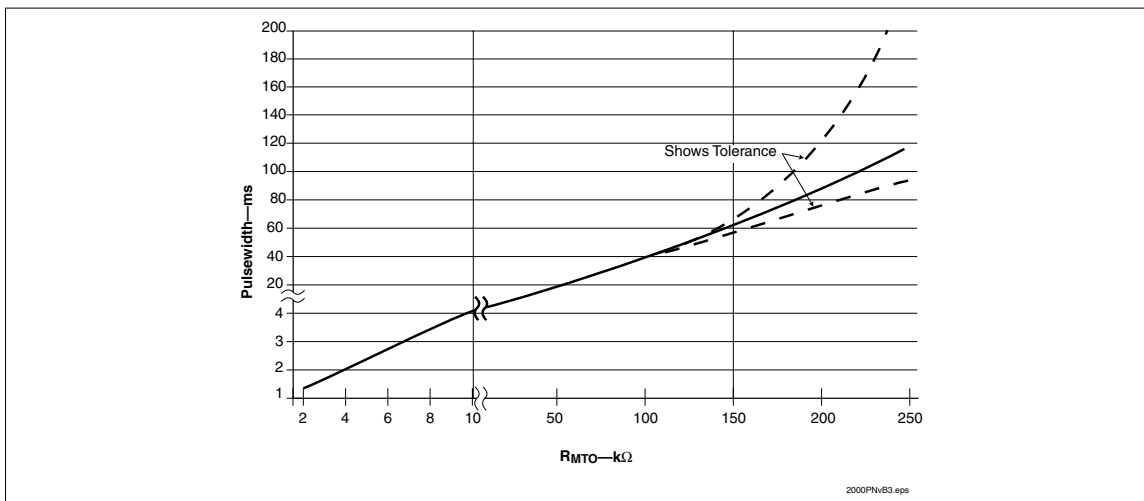

Figure 7. Relationship Between Trickle Pulse-Width and Value of R_{MTO}

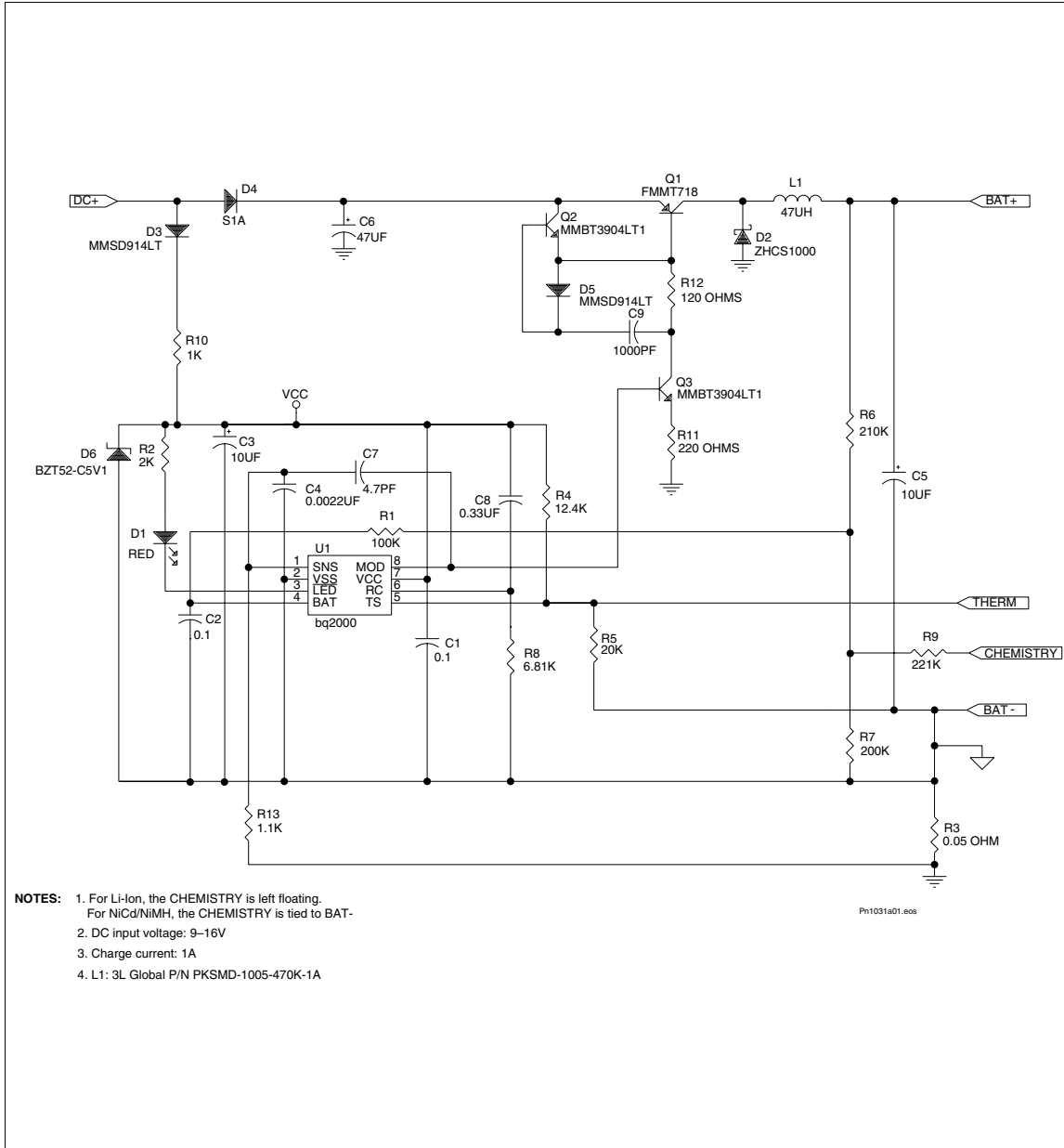

Figure 8. Single-Cell Li-Ion, Three-Cell NiCd/NiMH 1A Charger

Table 2. Summary of NiCd or NiMH Charging Characteristics

Parameter	Value*
Maximum cell voltage (V_{MCV})	2V
Minimum pre-charge qualification voltage (V_{LBAT})	950mV
High-temperature cutoff voltage (V_{TCO})	$0.225 * V_{CC}$
High-temperature fault voltage (V_{HTF})	$0.25 * V_{CC}$
Low-temperature fault voltage (V_{LTF})	$0.5 * V_{CC}$
bq2000 fast-charge maximum time out (MTO)	$R_{MTO} * C_{MTO} * 35,988$
Fast-charge charging current (I_{MAX})	$0.05/R_{SNS}$
Hold-off period	MTO/32
Top-off charging current (optional)	$I_{MAX}/16$
Top-off period (optional)	MTO
Trickle-charge frequency	1Hz
Trickle-charge pulse-width	See Figure 7

*Please refer to DC Thresholds Specification for details.

SNS voltage is less than V_{SNSLO} or greater than V_{SNSHI} , the bq2000 switches the MOD output low to shut off charging current to the battery. Figure 8 shows a typical multi-chemistry charge circuit.

Temperature Monitoring

The bq2000 measures the temperature by the voltage at the TS pin. This voltage is typically generated by a neg-

ative-temperature-coefficient thermistor. The bq2000 compares this voltage against its internal threshold voltages to determine if charging is safe. These thresholds are the following:

- High-temperature cutoff voltage: $V_{TCO} = 0.225 * V_{CC}$
This voltage corresponds to the maximum temperature (TCO) at which fast charging is allowed. The bq2000 terminates fast charge if the voltage on pin TS falls below V_{TCO} .

Table 3. Summary of Li-Ion Charging Characteristics

Parameter	Value*
Maximum cell voltage (V_{MCV})	2V
Minimum pre-charge qualification voltage (V_{LBAT})	950mV
High-temperature cutoff voltage (V_{TCO})	$0.225 * V_{CC}$
High-temperature fault voltage (V_{HTF})	$0.25 * V_{CC}$
Low-temperature fault voltage (V_{LTF})	$0.5 * V_{CC}$
bq2000 fast-charge maximum time-out (MTO)	$2 * R_{MTO} * C_{MTO} * 35,988$
Fast-charge charging current (I_{MAX})	$0.05/R_{SNS}$
Hold-off period	MTO/32
Minimum current (for fast-charge termination)	$I_{MAX}/7$
Trickle-charge frequency (before fast charge only)	1Hz
Trickle-charge pulse-width (before fast charge only)	See Figure 7

*Please refer to DC Thresholds Specification for details.

bq2000

Table 4. Temperature-Monitoring Conditions

Temperature	Condition	Action
$V_{TS} > V_{LTF}$	Cold battery—checked at all times	Suspends fast charge or top-off and timer Allows trickle charge—LED flashes at 1Hz rate during pre-charge qualification and fast charge
$V_{HTF} < V_{TS} < V_{LTF}$	Optimal operating range	Allows charging
$V_{TS} < V_{HTF}$	Hot battery—checked during charge qualification and top-off and trickle-charge	Suspends fast-charge initiation, does not allow trickle charge—LED flashes at 1Hz rate during pre-charge qualification and fast charge
$V_{TS} < V_{TCO}$	Battery exceeding maximum allowable temperature—checked at all times	Terminates fast charge or top-off

- High-temperature fault voltage: $V_{HTF} = 0.25 * V_{CC}$ This voltage corresponds to the temperature (HTF) at which fast charging is allowed to begin.
- Low-temperature fault voltage: $V_{LTF} = 0.5 * V_{CC}$ This voltage corresponds to the minimum temperature (LTF) at which fast charging or top-off is allowed. If the voltage on pin TS rises above V_{LTF} , the bq2000 suspends fast charge or top-off but does not terminate charge. When the voltage falls back below V_{LTF} , fast charge or top-off resumes from the point where suspended. Trickle-charge is allowed during this condition.

Table 4 summarizes these various conditions.

Charge Status Display

The charge status is indicated by open-drain output LED. Table 5 summarizes the display output of the bq2000.

Table 5. Charge Status Display

Charge Action State	LED Status
Battery absent	High impedance
Pre-charge qualification	1Hz flash
Trickle charge (before fast charge)	1Hz flash
Fast charging	Low
Top-off or trickle (after fast charge, NiCd, NiMH only)	High impedance
Charge complete	High impedance
Sleep mode	High impedance
Charge suspended ($V_{TS} > V_{LTF}$)	1Hz flash

Sleep Mode

The bq2000 features a sleep mode for low power consumption. This mode is enabled when the voltage at pin BAT is above the low-power-mode threshold, V_{SLP} . During sleep mode, the bq2000 shuts down all internal circuits, drives the LED output to high-impedance state, and drives pin MOD to low. Restoring BAT below the V_{MCV} threshold initiates the IC and starts a fast-charge cycle.

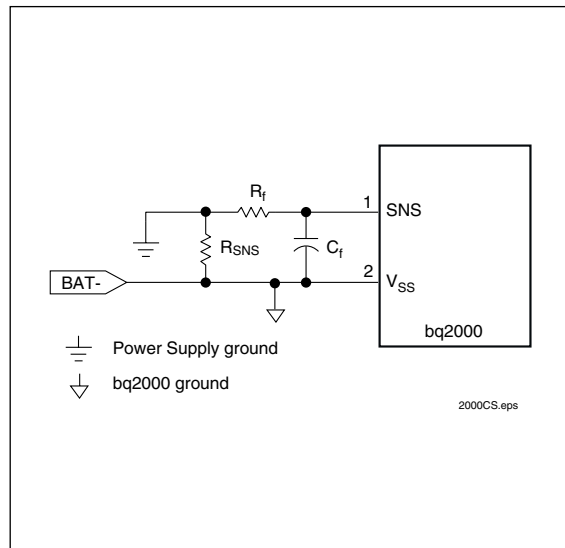

Figure 9. Current-Sensing Circuit

Absolute Maximum Ratings

Symbol	Parameter	Minimum	Maximum	Unit	Notes
V _{CC}	V _{CC} relative to V _{SS}	-0.3	+7.0	V	
V _T	DC voltage applied on any pin, excluding V _{CC} relative to V _{SS}	-0.3	+7.0	V	
T _{OPR}	Operating ambient temperature	-20	+70	°C	
T _{STG}	Storage temperature	-40	+125	°C	
T _{SOLDER}	Soldering temperature	-	+260	°C	10s max.

Note: Permanent device damage may occur if Absolute Maximum Ratings are exceeded. Functional operation should be limited to the Recommended DC Operating Conditions detailed in this data sheet. Exposure to conditions beyond the operational limits for extended periods of time may affect device reliability.

DC Thresholds (T_A = T_{OPR}; V_{CC} = 5V ±20% unless otherwise specified)

Symbol	Parameter	Rating	Tolerance	Unit	Notes
V _{TCO}	Temperature cutoff	0.225 * V _{CC}	±5%	V	Voltage at pin TS
V _{HTF}	High-temperature fault	0.25 * V _{CC}	±5%	V	Voltage at pin TS
V _{LTF}	Low-temperature fault	0.5 * V _{CC}	±5%	V	Voltage at pin TS
V _{MCV}	Maximum cell voltage	2.00	±0.75%	V	V _{BAT} > V _{MCV} inhibits fast charge
V _{LBAT}	Minimum cell voltage	950	±5%	mV	Voltage at pin BAT
PVD	BAT input change for PVD detection	3.8	±20%	mV	
V _{SNSHI}	High threshold at SNS, resulting in MOD-low	50	±10	mV	Voltage at pin SNS
V _{SNSLO}	Low threshold at SNS, resulting in MOD-high	-50	±10	mV	Voltage at pin SNS
V _{SLP}	Sleep-mode input threshold	V _{CC} - 1	±0.5	V	Applied to pin BAT
V _{RCH}	Recharge threshold	V _{MCV} - 0.1	±0.02	V	At pin BAT

bq2000

Recommended DC Operating Conditions (TA = TOPR)

Symbol	Condition	Minimum	Typical	Maximum	Unit	Notes
V _{CC}	Supply voltage	4.0	5.0	6.0	V	
I _{CC}	Supply current	-	0.5	1	mA	Exclusive of external loads
I _{CCS}	Sleep current	-	-	5	μA	V _{BAT} = V _{SLP}
V _{TS}	Thermistor input	0.5	-	V _{CC}	V	V _{TS} < 0.5V prohibited
V _{OH}	Output high	V _{CC} - 0.6	-	-	V	MOD, I _{OH} = 10mA
V _{OL}	Output low	-	-	0.2	V	MOD, LED, I _{OL} = 10mA
I _{OZ}	High-impedance leakage current	-	-	5	μA	LED
I _{snk}	Sink current	-	-	20	mA	MOD, LED
R _{MTO}	Charge timer resistor	2	-	250	kΩ	
C _{MTO}	Charge timer capacitor	0.001	-	1.0	μF	

Note: All voltages relative to V_{SS} except as noted.

Impedance

Symbol	Parameter	Minimum	Typical	Maximum	Unit
R _{BAT}	Battery input impedance	10	-	-	MΩ
R _{TS}	TS input impedance	10	-	-	MΩ
R _{SNS}	SNS input impedance	10	-	-	MΩ

Timing (TA = TOPR; V_{CC} = 5V ±20% unless otherwise specified)

Symbol	Parameter	Minimum	Typical	Maximum	Unit
d _{MTO}	MTO time-base variation	-5	-	+5	%
f _{TRKL}	Pulse-trickle frequency	0.9	1.0	1.1	Hz

8-Pin DIP (PN)

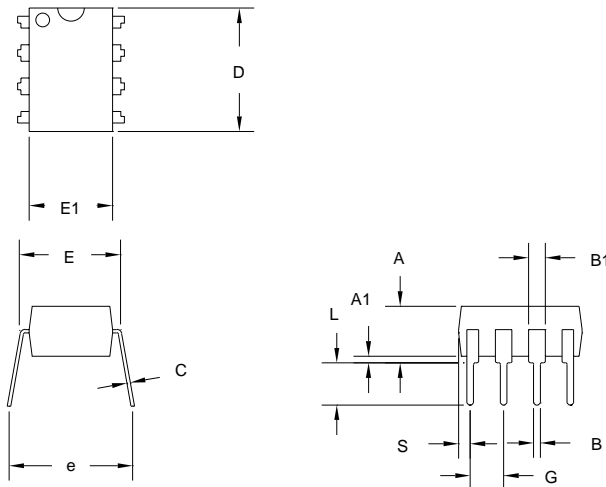

8-Pin PN (0.300" DIP)

Dimension	Inches		Millimeters	
	Min.	Max.	Min.	Max.
A	0.160	0.180	4.06	4.57
A1	0.015	0.040	0.38	1.02
B	0.015	0.022	0.38	0.56
B1	0.055	0.065	1.40	1.65
C	0.008	0.013	0.20	0.33
D	0.350	0.380	8.89	9.65
E	0.300	0.325	7.62	8.26
E1	0.230	0.280	5.84	7.11
e	0.300	0.370	7.62	9.40
G	0.090	0.110	2.29	2.79
L	0.115	0.150	2.92	3.81
S	0.020	0.040	0.51	1.02

8-Pin SOIC Narrow (SN)

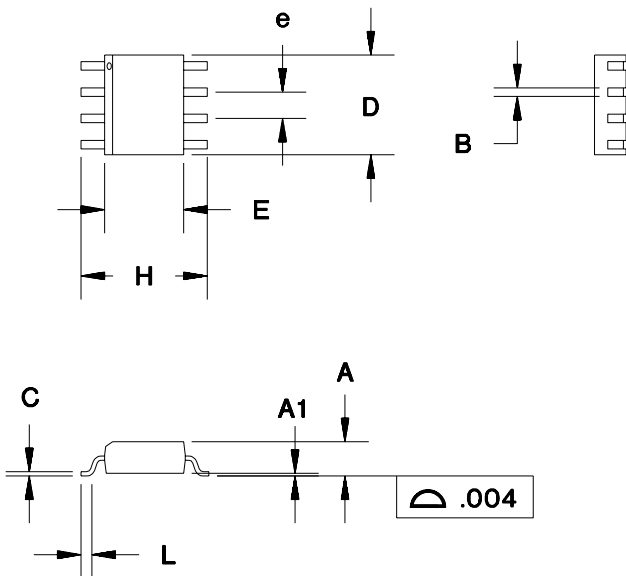

8-Pin SN (0.150" SOIC)

Dimension	Inches		Millimeters	
	Min.	Max.	Min.	Max.
A	0.060	0.070	1.52	1.78
A1	0.004	0.010	0.10	0.25
B	0.013	0.020	0.33	0.51
C	0.007	0.010	0.18	0.25
D	0.185	0.200	4.70	5.08
E	0.150	0.160	3.81	4.06
e	0.045	0.055	1.14	1.40
H	0.225	0.245	5.72	6.22
L	0.015	0.035	0.38	0.89

bq2000

8-Pin TSSOP (PW)

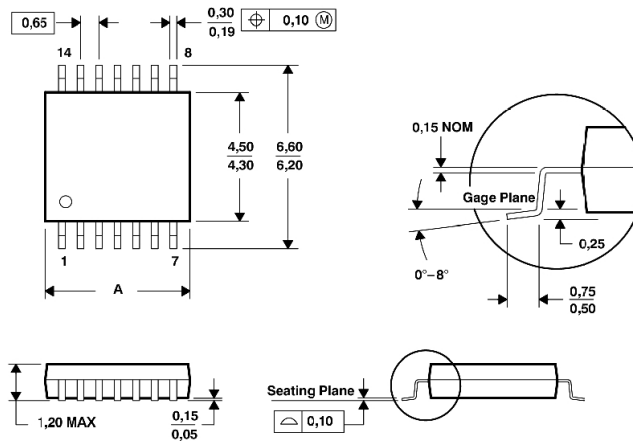

DIM \ PINS **	8	14	16	20	24	28
A MAX	3,10	5,10	5,10	6,60	7,90	9,80
A MIN	2,90	4,90	4,90	6,40	7,70	9,60

4040064/F 01/97

- NOTES: A. All linear dimensions are in millimeters.
 B. This drawing is subject to change without notice.
 C. Body dimensions do not include mold flash or protrusion not to exceed 0,15.
 D. Falls within JEDEC MO-153

Data Sheet Revision History

Change No.	Page No.	Description	Nature of Change
1	4	MTO equation	Was: $MTO = R * C * 71,976$ Is: $MTO = R_{MTO} * C_{MTO} * 35,988$
1	6	Trickle-pulse width equation	Replaced equation with Figure 6
1	7	Figure 7	Schematic updated
1	10	V_{TCO} , V_{HTF} , V_{LTF}	Tolerance updated
1	11	R_{MTO} , C_{MTO}	Values updated
2	8	V_{LBAT}	Corrected values in Tables 2 and 3
3	1, 13	Package option	Added TSSOP
3	3	State diagram	Added
3	8	Schematic updated	
3	11	V_{TSO} , V_{HTF} , V_{LTF}	Tolerance updated
3	7	Top-off charge	Updated requirement for enabling top-off
4	7	Figure 7	Updated tolerance on the curve
4	12	V_{OH}	Was: Minimum $V_{OH} = V_{CC} - 0.2$ at $I_{OH} = 20mA$ Is: Minimum $V_{OH} = V_{CC} - 0.6$ at $I_{OH} = 10mA$
4	12	V_{OL}	Was: $I_{OH} = 20mA$ Is: $I_{OH} = 10mA$
5	3	Figure 2	Battery voltage detail was: (checked at all times) Is: Voltage regulation checked constantly. PVD checked at rate of MTO/64.
5	3	Figure 2	Battery temperature detail was: (checked at all times) Is: (checked 1,750 times per second)
6	14	Change package	Was: 8-Pin TSSOP ~ TS Package Suffix Is: 8-Pin PSOP
5	15	Change ordering information	Was: TS = 8-pin TSSOP Is: PW = 8-pin TSSOP

Note: Change 1 = Jan. 1999 B changes to Final from Sept. 1998 Preliminary data sheet.

Change 2 = Mar. 1999 C changes from Jan. 1999 B.

Change 3 = May 1999 D changes from Mar. 1999 C.

Change 4 = February 2000 E changes from May 1999 D.

Change 5 = February 2001 F changes from February 2000 E

bq2000

Ordering Information

bq2000

Package Option:

PN = 8-pin narrow plastic DIP

SN = 8-pin narrow SOIC

PW = 8-pin TSSOP

Device:

bq2000 Multi-Chemistry Fast-Charge IC with Peak Voltage Detection

PACKAGING INFORMATION

Orderable Device	Status (1)	Package Type	Package Drawing	Pins	Package Qty	Eco Plan (2)	Lead/ Ball Finish	MSL Peak Temp (3)
BQ2000PN-B5	ACTIVE	PDIP	P	8	50	Pb Free (RoHS)	CU NIPDAU	Level-NA-NA-NA
BQ2000PW	ACTIVE	TSSOP	PW	8	150	Green (RoHS & no Sb/Br)	CU NIPDAU	Level-2-260C-1 YEAR
BQ2000PWG4	ACTIVE	TSSOP	PW	8	150	Green (RoHS & no Sb/Br)	CU NIPDAU	Level-2-260C-1 YEAR
BQ2000PWR	ACTIVE	TSSOP	PW	8	2000	Green (RoHS & no Sb/Br)	CU NIPDAU	Level-2-260C-1 YEAR
BQ2000PWRG4	ACTIVE	TSSOP	PW	8	2000	Green (RoHS & no Sb/Br)	CU NIPDAU	Level-2-260C-1 YEAR
BQ2000SN-B5	ACTIVE	SOIC	D	8	75	Green (RoHS & no Sb/Br)	CU NIPDAU	Level-1-260C-UNLIM
BQ2000SN-B5G4	ACTIVE	SOIC	D	8	75	Green (RoHS & no Sb/Br)	CU NIPDAU	Level-1-260C-UNLIM
BQ2000SN-B5TR	ACTIVE	SOIC	D	8	2500	Green (RoHS & no Sb/Br)	CU NIPDAU	Level-1-260C-UNLIM
BQ2000SN-B5TRG4	ACTIVE	SOIC	D	8	2500	Green (RoHS & no Sb/Br)	CU NIPDAU	Level-1-260C-UNLIM

(1) The marketing status values are defined as follows:

ACTIVE Product device recommended for new designs.

LIFEBUY: TI has announced that the device will be discontinued, and a lifetime-buy period is in effect.

NRND: Not recommended for new designs. Device is in production to support existing customers, but TI does not recommend using this part in a new design.

PREVIEW: Device has been announced but is not in production. Samples may or may not be available.

OBSOLETE TI has discontinued the production of the device.

(2) Eco Plan -The planned eco-friendly classification: Pb-Free (RoHS), Pb-Free (RoHS Exempt), or Green (RoHS & no Sb/Br) -please check

<http://www.ti.com/productcontent> for the latest availability information and additional product content details.

TBD: The Pb-Free/Green conversion plan has not been defined.

Pb-Free (RoHS): TI's terms "Lead-Free" or "Pb-Free" mean semiconductor products that are compatible with the current RoHS requirements

for all 6 substances, including the requirement that lead not exceed 0.1% by weight in homogeneous materials. Where designed to be soldered

at high temperatures, TI Pb-Free products are suitable for use in specified lead-free processes.

Pb-Free (RoHS Exempt): This component has a RoHS exemption for either 1) lead-based flip-chip solder bumps used between the die and

package, or 2) lead-based die adhesive used between the die and leadframe. The component is otherwise considered Pb-Free (RoHS compatible) as defined above.

Green (RoHS & no Sb/Br): TI defines "Green" to mean Pb-Free (RoHS compatible), and free of Bromine (Br) and Antimony (Sb) based flame

retardants (Br or Sb do not exceed 0.1% by weight in homogeneous material)

(3) MSL, Peak Temp. --The Moisture Sensitivity Level rating according to the JEDEC industry standard classifications, and peak solder temperature.

Important Information and Disclaimer: The information provided on this page represents TI's knowledge and belief as of the date that it is provided. TI bases its knowledge and belief on information provided by third parties, and makes no representation or warranty as to the accuracy of such information. Efforts are underway to better integrate information from third parties. TI has taken and continues to take reasonable steps to provide representative and accurate information but may not have conducted destructive testing or chemical analysis on incoming materials and chemicals. TI and TI suppliers consider certain information to be proprietary, and thus CAS numbers and other limited information may not be available for release.

In no event shall TI's liability arising out of such information exceed the total purchase price of the TI part(s) at issue in this document sold by TI to Customer on an annual basis.

Addendum-Page 1