



Powerline Communications Analog Front-End

Check for Samples: [AFE030](#)

FEATURES

- **Integrated Powerline Driver with Thermal and Overcurrent Protection**
- **Conforms to EN50065-1**
- **Pin-Compatible to [AFE031](#)**
- **Large Output Swing: 13 V_{PP} at 1.0 A (15-V Supply)**
- **Low Power Consumption: 15 mW (Receive Mode)**
- **Programmable Tx and Rx Filters**
- **Supports EN50065 CENELEC Bands A, B, C, D**
- **Supports OFDM, FSK, and S-FSK**
- **Supports IEC 61334**
- **Receive Sensitivity: 20 μV_{RMS}, Typical**
- **Programmable Tx/Rx Gain Control**
- **Four-Wire Serial Peripheral Interface**
- **Two Integrated Zero Crossing Detectors**
- **Two-Wire Transceiver Buffer**
- **Package: QFN-48 PowerPAD™**
- **Extended Junction Temperature Range: –40°C to +125°C**

APPLICATIONS

- **eMetering**
- **Lighting**
- **Solar**
- **Pilot Wire**

DESCRIPTION

The AFE030 is a low-cost, integrated, powerline communications (PLC) analog front-end (AFE) device that is capable of capacitive- or transformer-coupled connections to the powerline while under the control of a digital signal processor (DSP) or microcontroller. It is ideal for driving low-impedance lines that require up to 1.0 A into reactive loads. The integrated receiver is able to detect signals down to 20 μV_{RMS} and is capable of a wide range of gain options to adapt to varying input signal conditions. This monolithic integrated circuit provides high reliability in demanding powerline communications applications.

The AFE030 transmit power amplifier operates from a single supply in the range of 7 V to 26 V. At maximum output current, a wide output swing provides a 12-V_{PP} (I_{OUT} = 1.0 A) capability with a nominal 15-V supply. The analog and digital signal processing circuitry operates from a single 3.3-V power supply.

The AFE030 is internally protected against overtemperature and short-circuit conditions. It also provides an adjustable current limit. An interrupt output is provided that indicates both current limit and thermal limit. There is also a shutdown pin that can be used to quickly put the device into its lowest power state. Through the four-wire serial peripheral interface, or SPI™, each functional block can be enabled or disabled to optimize power dissipation.

The AFE030 is housed in a thermally-enhanced, surface-mount PowerPAD package (QFN-48). Operation is specified over the extended industrial junction temperature range of –40°C to +125°C.

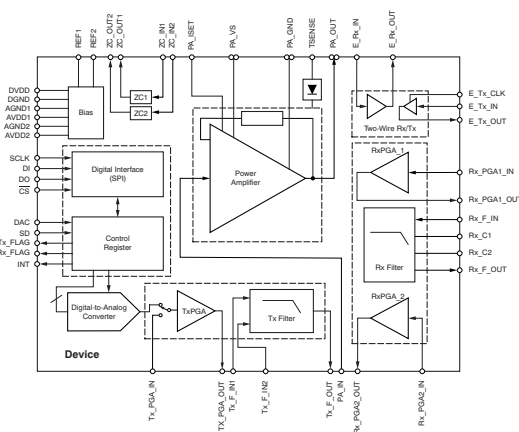

Please be aware that an important notice concerning availability, standard warranty, and use in critical applications of Texas Instruments semiconductor products and disclaimers thereto appears at the end of this data sheet.

PowerPAD, C2000 are trademarks of Texas Instruments.

SPI is a trademark of Motorola, Inc.

All other trademarks are the property of their respective owners.



This integrated circuit can be damaged by ESD. Texas Instruments recommends that all integrated circuits be handled with appropriate precautions. Failure to observe proper handling and installation procedures can cause damage.

ESD damage can range from subtle performance degradation to complete device failure. Precision integrated circuits may be more susceptible to damage because very small parametric changes could cause the device not to meet its published specifications.

PACKAGE/ORDERING INFORMATION⁽¹⁾

PRODUCT	PACKAGE-LEAD	PACKAGE DESIGNATOR	PACKAGE MARKING
AFE030AIRGZT	QFN-48 PowerPAD	RGZ	AFE030A
AFE030AIRGZR	QFN-48 PowerPAD	RGZ	AFE030A

(1) For the most current package and ordering information see the Package Option Addendum at the end of this document, or visit the device product folder at www.ti.com.

ABSOLUTE MAXIMUM RATINGS⁽¹⁾

Over operating free-air temperature range, unless otherwise noted.

		VALUE	UNIT
Supply voltage, PA_V _S		+26	V
Signal input terminal, pins 18,19	Voltage ⁽²⁾	PA_GND – 0.4 to PA_V _S + 0.4	V
	Current ⁽²⁾	±10	mA
Supply voltage, AV _{DD}		+5.5	V
Signal input terminal, pins 13, 15, 16, 21, 23-25, 28, 32, 34, 35, 38, 39, 46	Voltage ⁽²⁾	AGND – 0.4 to AV _{DD} + 0.4	V
	Current ⁽²⁾	±10	mA
Signal input terminal, pin 27	Voltage limit	±10	V
Signal input terminal, pin 10	Current limit	±10	mA
Supply voltage, DV _{DD}		+5.5	V
Signal input terminal, pins 3, 4, 6, 7, 8	Voltage ⁽²⁾	DGND – 0.4 to DV _{DD} + 0.4	V
	Current ⁽²⁾	±10	mA
Signal output terminal, pins 5, 9, 14, 17, 20, 22, 26, 31, 33, 36, 37, 47, 48	Current ⁽²⁾	Continuous	
Output short-circuit (PA), pins 42,43 ⁽²⁾⁽³⁾⁽⁴⁾		Continuous	
Operating temperature, T _A ⁽⁴⁾		–40 to +150	°C
Storage temperature, T _A		–55 to +150	°C
Junction temperature, T _J		+150	°C
ESD ratings	Human body model (HBM)	3000	V
	Machine model (MM)	200	V
	Charged device model (CDM)	500	V

- (1) Stresses above these ratings may cause permanent damage. Exposure to absolute maximum conditions for extended periods may degrade device reliability. These are stress ratings only, and functional operation of the device at these or any other conditions beyond those specified is not implied.
- (2) Input terminals are diode-clamped to the power-supply rails. Input signals that can swing more than 0.4 V beyond the supply rails should be current limited to 10 mA or less. Output terminals are diode-clamped to the power-supply rails. Output signals that can swing more than 0.4 V beyond the supply rails should be current limited to 10 mA or less.
- (3) Short-circuit to ground.
- (4) The AFE030 automatically goes into shutdown at junction temperatures that exceed +165°C.

ELECTRICAL CHARACTERISTICS: Transmitter (Tx), Tx_DAC

 At $T_J = +25^\circ\text{C}$, $PA_{V_S} = 16\text{ V}$, $V_{AVDD} = V_{DVDD} = 3.3\text{ V}$, and PA_ISET (pin 46) connected to ground, unless otherwise noted.

PARAMETER	CONDITIONS	AFE030			UNIT
		MIN	TYP	MAX	
Output range		GND + 0.1		$AV_{DD} - 0.1$	V
Resolution	1024 steps, 10-bit DAC		3.2		mV
THD	Total harmonic distortion at 62.5 kHz ⁽¹⁾	Second-harmonic distortion		-73	dB
		Third-harmonic distortion		-56	dB
		Fourth-harmonic distortion		-94	dB
Data rate			1.5		MSPS

 (1) Total harmonic distortion measured at output of Tx_PGA configured in a gain of 1 V/V with an amplitude of 3 V_{PP} , at a 1-MHz sample rate.

ELECTRICAL CHARACTERISTICS: Transmitter (Tx), Tx_PGA

 At $T_J = +25^\circ\text{C}$, $PA_{V_S} = 16\text{ V}$, $V_{AVDD} = V_{DVDD} = 3.3\text{ V}$, and PA_ISET (pin 46) connected to ground, unless otherwise noted.

PARAMETER	CONDITIONS	AFE030			UNIT	
		MIN	TYP	MAX		
INPUT						
Input voltage range		GND - 0.1		$AV_{DD} + 0.1$	V	
R_I	Input resistance	$G = 1\text{ V/V}$		58	k Ω	
		$G = 0.707\text{ V/V}$		68	k Ω	
		$G = 0.5\text{ V/V}$		77	k Ω	
		$G = 0.25\text{ V/V}$		92	k Ω	
FREQUENCY RESPONSE						
BW	Bandwidth	DAC mode enabled				
		$G = 1\text{ V/V}$		8	MHz	
		$G = 0.707\text{ V/V}$		9	MHz	
		$G = 0.5\text{ V/V}$		10	MHz	
		$G = 0.25\text{ V/V}$		12	MHz	
OUTPUT						
V_O	Voltage output swing from AGND or AV_{DD}	$R_{LOAD} = 10\text{ k}\Omega$, connected to $AV_{DD}/2$		10	100	mV
I_O	Maximum continuous current, dc	Sourcing		25		mA
		Sinking		25		mA
R_O	Output resistance	$f = 100\text{ kHz}$		1		Ω
GAIN						
Gain error	For all gains		-1	± 0.1	+1	%
Gain error drift	$T_J = -40^\circ\text{C}$ to $+125^\circ\text{C}$			6		ppm/ $^\circ\text{C}$

ELECTRICAL CHARACTERISTICS: Transmitter (Tx), Tx_FILTER

 At $T_J = +25^\circ\text{C}$, $PA_{V_S} = 16\text{ V}$, $V_{AVDD} = V_{DVDD} = 3.3\text{ V}$, and PA_ISET (pin 46) connected to ground, unless otherwise noted.

PARAMETER	CONDITIONS	AFE030			UNIT
		MIN	TYP	MAX	
INPUT					
Input voltage range		GND – 0.1		$AV_{DD} + 0.1$	V
R_i Input resistance (Tx_F_IN1 and Tx_F_IN2)			43		k Ω
FREQUENCY RESPONSE					
CENELEC A Mode					
Passband frequency	–3 dB		95		kHz
Stop band attenuation		–50	–60		dB
Stop band frequency			910		kHz
Filter gain			0		dB
CENELEC B/C/D MODES					
Passband frequency	–3 dB		145		kHz
Stop band attenuation		–50	–60		dB
Stop band frequency			870		kHz
Filter gain			0		dB
OUTPUT					
V_O Voltage output swing from AGND or AV_{DD}	$R_{LOAD} = 10\text{ k}\Omega$, connected to $AV_{DD}/2$		10	100	mV
I_O Maximum continuous current, dc	Sourcing		25		mA
	Sinking		25		mA
R_O Output resistance	$f = 100\text{ kHz}$		1		Ω
TRANSMITTER NOISE					
Integrated noise at PA output ⁽¹⁾	CENELEC Band A (40 kHz to 90 kHz)	Noise-reducing capacitor = 1 nF from pin 19 to ground		435	μV_{RMS}
	CENELEC Bands B/C/D (95 kHz to 140 kHz)	Noise-reducing capacitor = 1 nF from pin 19 to ground		460	μV_{RMS}

(1) Includes DAC, Tx_PGA, Tx_Filter, PA, and REF1 bias generator.

ELECTRICAL CHARACTERISTICS: Power Amplifier (PA)

 At $T_J = +25^\circ\text{C}$, $PA_{V_S} = 16\text{ V}$, $V_{AVDD} = V_{DVDD} = 3.3\text{ V}$, and PA_ISET (pin 46) connected to ground, unless otherwise noted.

PARAMETER		CONDITIONS	AFE030			UNIT
			MIN	TYP	MAX	
INPUT						
Input voltage range			GND – 0.1	$PA_{V_S} + 0.1$		V
R_I	Input resistance			20		k Ω
FREQUENCY RESPONSE						
BW	Bandwidth	$I_{LOAD} = 0$		670		kHz
SR	Slew rate	10-V step		19		V/ μs
Full-power bandwidth		$V_{OUT} = 10\text{ V}_{PP}$		300		kHz
AC PSRR		$f = 50\text{ kHz}$		14		dB
OUTPUT						
V_O	Voltage output swing	From PA_{V_S}	$I_O = 300\text{ mA}$, sourcing	0.3	1	V
			$I_O = 1.0\text{ A}$, sourcing	1	1.5	V
		From PA_{Gnd}	$I_O = 300\text{ mA}$, sinking	0.3	1	V
			$I_O = 1.0\text{ A}$, sinking	1	1.5	V
I_O	Maximum continuous current, dc	PA_ISET (pin 46) connected to ground	1.0			A
Maximum peak current, ac		$T_J = -40^\circ\text{C}$ to $+125^\circ\text{C}$, $f = 50\text{ kHz}$	1.0			A
R_O	Output resistance	$I_O = 1.0\text{ A}$	0.1			Ω
PA disabled		Output impedance, $f = 100\text{ kHz}$, REF1 enabled	145 120			k Ω pF
Output current limit range			± 0.4 to ± 1.0			A
Current limit equation			$I_{LIM} = 20\text{ k} \times [1.2\text{ V}/(R_{SET} + 15\text{ k}\Omega)]$			A
		Solved for R_{SET} (current limit)	$R_{SET} = [(20\text{ k} \times 1.2\text{ V}/I_{LIM}) - 15\text{ k}\Omega]$			Ω
GAIN ($R_{LOAD} = 1\text{ k}\Omega$)						
G	Nominal gain		6.5			V/V
Gain error			-1	0.1	+1	%
Gain error drift		$T_J = -40^\circ\text{C}$ to $+125^\circ\text{C}$	± 1			ppm/ $^\circ\text{C}$
TSENSE DIODE						
η	Diode ideality factor		1.033			
THERMAL SHUTDOWN						
Junction temperature at shutdown			+165			$^\circ\text{C}$
Hysteresis			20			$^\circ\text{C}$
Return to normal operation			+145			$^\circ\text{C}$

ELECTRICAL CHARACTERISTICS: Receiver (Rx), Rx PGA1

At $T_J = +25^\circ\text{C}$, $PA_{V_S} = 16\text{ V}$, $V_{AVDD} = V_{DVDD} = 3.3\text{ V}$, and PA_ISET (pin 46) connected to ground, unless otherwise noted.

PARAMETER	CONDITIONS	AFE030			UNIT
		MIN	TYP	MAX	
INPUT					
Input voltage range			10		V_{PP}
R_I Input resistance	$G = 2\text{ V/V}$		10		$k\Omega$
	$G = 1\text{ V/V}$		15		$k\Omega$
	$G = 0.5\text{ V/V}$		20		$k\Omega$
	$G = 0.25\text{ V/V}$		24		$k\Omega$
FREQUENCY RESPONSE					
BW Bandwidth	$G = 2\text{ V/V}$		6		MHz
	$G = 1\text{ V/V}$		10		MHz
	$G = 0.5\text{ V/V}$		13		MHz
	$G = 0.25\text{ V/V}$		15		MHz
OUTPUT					
V_O Voltage output swing from AGND or AV_{DD}	$R_{LOAD} = 6\text{ k}\Omega$, connected to $AV_{DD}/2$		10	100	mV
I_O Maximum continuous current, dc	Sourcing		25		mA
	Sinking		25		mA
R_O Output resistance	$G = 1$, $f = 100\text{ kHz}$		1		Ω
GAIN					
Gain error	$G = 0.25\text{ V/V}$	-1	± 0.1	+1	%
	$G = 0.5\text{ V/V}$	-1	± 0.1	+1	%
	$G = 1\text{ V/V}$	-1	± 0.1	+1	%
	$G = 2\text{ V/V}$	-2	± 0.2	+2	%
Gain error drift	$T_J = -40^\circ\text{C}$ to $+125^\circ\text{C}$		1		ppm/ $^\circ\text{C}$

ELECTRICAL CHARACTERISTICS: Receiver (Rx), Rx Filter

 At $T_J = +25^\circ\text{C}$, $PA_{V_S} = 16\text{ V}$, $V_{AVDD} = V_{DVDD} = 3.3\text{ V}$, and PA_{ISET} (pin 46) connected to ground, unless otherwise noted.

PARAMETER	CONDITIONS	AFE030			UNIT	
		MIN	TYP	MAX		
INPUT						
	Input voltage range	GND – 0.1		$AV_{DD} + 0.1$	V	
R_{IN}	Input resistance		6		k Ω	
FREQUENCY RESPONSE, CENELEC A MODE (Rx_C1 = 680 pF, Rx_C2 = 680 pF)						
	Passband frequency	–3 dB		90	kHz	
	Stop band attenuation		–25	–33	dB	
	Stop band frequency			270	kHz	
	Filter gain			0	dB	
FREQUENCY RESPONSE, CENELEC B/C/D MODES (Rx_C1 = 270 pF, Rx_C2 = 560 pF)						
	Passband frequency	–3 dB		145	kHz	
	Stop band attenuation		–25	–35	dB	
	Stop band frequency			350	kHz	
	Filter gain			0	dB	
OUTPUT						
V_O	Voltage output swing from AGND or AV_{DD}	$R_{LOAD} = 10\text{ k}\Omega$, connected to $AV_{DD}/2$		10	100	mV
I_O	Maximum continuous current, dc	Sourcing		25		mA
		Sinking		25		mA
R_O	Output resistance	$f = 100\text{ kHz}$		5		Ω

ELECTRICAL CHARACTERISTICS: Receiver (Rx), Rx PGA2

At $T_J = +25^\circ\text{C}$, $PA_{V_S} = 16\text{ V}$, $V_{AVDD} = V_{DVDD} = 3.3\text{ V}$, and PA_{ISET} (pin 46) connected to ground, unless otherwise noted.

PARAMETER	CONDITIONS	AFE030			UNIT
		MIN	TYP	MAX	
INPUT					
Input voltage range		GND – 0.1		$AV_{DD} + 0.1$	V
R_I Input impedance	$G = 64\text{ V/V}$		1.7		k Ω
	$G = 16\text{ V/V}$		6.3		k Ω
	$G = 4\text{ V/V}$		21		k Ω
	$G = 1\text{ V/V}$		53		k Ω
FREQUENCY RESPONSE					
BW Bandwidth	$G = 64\text{ V/V}$		300		kHz
	$G = 16\text{ V/V}$		800		kHz
	$G = 4\text{ V/V}$		1.4		MHz
	$G = 1\text{ V/V}$		4		MHz
OUTPUT					
V_O Voltage output swing from AGND or AV_{DD}	$R_{LOAD} = 10\text{ k}\Omega$, connected to $AV_{DD}/2$		10	100	mV
I_O Maximum continuous current, dc	Sourcing		25		mA
	Sinking		25		mA
R_O Output impedance	$G = 1$, $f = 100\text{ kHz}$		1		Ω
GAIN					
Gain error	$G = 1\text{ V/V}$	–2	± 1	2	%
	$G = 4\text{ V/V}$	–2	± 1	2	%
	$G = 16\text{ V/V}$	–2	± 1	2	%
	$G = 64\text{ V/V}$	–4	± 1	4	%
Gain error drift	$T_J = -40^\circ\text{C}$ to $+125^\circ\text{C}$		6		ppm/ $^\circ\text{C}$
Rx SENSITIVITY					
Integrated noise, RTI ⁽¹⁾	CENELEC Band A (40 kHz to 90 kHz)	Noise-reducing capacitor = 1 μF from pin 28 to ground		14	μV_{RMS}
	CENELEC Bands B/C/D (95 kHz to 140 kHz)	Noise-reducing capacitor = 1 μF from pin 28 to ground		11	μV_{RMS}

(1) Includes Rx PGA1, Rx_Filter, Rx PGA2, and REF2 bias generator.

ELECTRICAL CHARACTERISTICS: Digital

At $T_J = +25^\circ\text{C}$, $PA_{V_S} = 16\text{ V}$, $V_{AVDD} = V_{DVDD} = 3.3\text{ V}$, and PA_ISET (pin 46) connected to ground, unless otherwise noted.

PARAMETER	CONDITIONS	AFE030			UNIT
		MIN	TYP	MAX	
DIGITAL INPUTS (SCLK, DIN, $\overline{\text{CS}}$, DAC, SD)					
Leakage input current	$0 \leq V_{IN} \leq DV_{DD}$	-1	0.01	1	μA
V_{IH}	High-level input voltage	$0.7 \times DV_{DD}$			V
V_{IL}	Low-level input voltage	$0.3 \times DV_{DD}$			V
SD pin high	$SD > 0.7 \times DV_{DD}$	AFE030 in shutdown			
SD pin low	$SD < 0.3 \times DV_{DD}$	AFE030 in normal operation			
DAC pin high	$DAC > 0.7 \times DV_{DD}$	SPI access to DAC Registers			
DAC pin low	$DAC < 0.3 \times DV_{DD}$	SPI access to Command and Data Registers			
DIGITAL OUTPUTS (DO, ZC_OUT)					
V_{OH}	High-level output voltage	$I_{OH} = 3\text{ mA}$	$DV_{DD} - 0.4$	DV_{DD}	V
V_{OL}	Low-level output voltage	$I_{OL} = -3\text{ mA}$	GND	$GND + 0.4$	V
DIGITAL OUTPUTS (INT, Tx_Flag, Rx_Flag)					
I_{OH}	High-level output current	$V_{OH} = 3.3\text{ V}$		1	μA
V_{OL}	Low-level output voltage	$I_{OL} = 4\text{ mA}$		0.4	V
I_{OL}	Low-level output current	$V_{OL} = 400\text{ mV}$	4		mA
	INT pin high (open drain)	INT sink current $< 1\ \mu\text{A}$	Normal operation		μs
	INT pin low (open drain) ⁽¹⁾	INT $< 0.4\text{ V}$	Indicates an interrupt has occurred		μs
	Tx_Flag high (open drain)	Tx_Flag sink current $< 1\ \mu\text{A}$	Indicates Tx block is not ready		μs
	Tx_Flag low (open drain)	Tx_Flag $< 0.4\text{ V}$	Indicates Tx block is ready		μs
	Rx_Flag high (open drain)	Rx_Flag sink current $< 1\ \mu\text{A}$	Indicates Rx block is not ready		μs
	Rx_Flag low (open drain)	Rx_Flag $< 0.4\text{ V}$	Indicates Rx block is ready		μs
DIGITAL TIMING					
	Gain select time		0.2		μs
	Shutdown mode, enable time		4.0		μs
	Shutdown mode, disable time		2.0		μs
	Power-on reset (POR) power-up time	$DV_{DD} \geq 2\text{ V}$	50		μs

(1) When an interrupt is detected (INT pin low), the contents of the I_Flag and T_Flag Registers can be read to determine the reason for the interrupt.

ELECTRICAL CHARACTERISTICS: Two-Wire Interface

At $T_J = +25^\circ\text{C}$, $PA_{VS} = 16\text{ V}$, $V_{AVDD} = V_{DVDD} = 3.3\text{ V}$, and PA_ISET (pin 46) connected to ground, unless otherwise noted.

PARAMETER	CONDITIONS	AFE030			UNIT
		MIN	TYP	MAX	
TWO-WIRE TRANSMITTER					
Frequency range ⁽¹⁾			50		kHz
Leakage input current (E_Tx_In, E_Tx_Clk)	$0 \leq V_{IN} \leq DV_{DD}$	-1	0.01	1	μA
INPUT LOGIC LEVELS (E_Tx_In, E_Tx_Clk)					
V_{IH}	High-level input voltage	$0.7 \times DV_{DD}$			V
V_{IL}	Low-level input voltage	$0.3 \times DV_{DD}$			V
OUTPUT LOGIC LEVELS (E_Tx_Out)					
V_{OH}	High-level output voltage	$I_{OH} = 3\text{ mA}$	$AV_{DD} - 0.4$	AV_{DD}	V
V_{OL}	Low-level output voltage	$I_{OL} = -3\text{ mA}$	GND	$GND + 0.4$	V
TWO-WIRE RECEIVER					
Gain			-4.5		dB
Frequency range			300		kHz
Maximum sink current			25		mA
Maximum source current			25		mA
Input terminal offset	Referenced to $V_{AVDD}/2$	-100	10	100	mV
Input impedance			78		k Ω

(1) The two-wire transmitter circuit is tested at $Tx_CLK = 10\text{ MHz}$.

ELECTRICAL CHARACTERISTICS: Zero-Crossing Detector

At $T_J = +25^\circ\text{C}$, $PA_{VS} = 16\text{ V}$, $V_{AVDD} = V_{DVDD} = 3.3\text{ V}$, and PA_ISET (pin 46) connected to ground, unless otherwise noted.

PARAMETER	CONDITIONS	AFE030			UNIT
		MIN	TYP	MAX	
Input voltage range		$AV_{DD} - 0.4$		$AV_{DD} + 0.4$	V
Input current range		-10		+10	mA
Input capacitance			3		pF
Rising threshold		0.45	0.9	1.35	V
Falling threshold		0.25	0.5	0.75	V
Hysteresis		0.20	0.4	0.60	V
Jitter	50 Hz, 240 V_{RMS}		10		ns

ELECTRICAL CHARACTERISTICS: Internal Bias Generator

At $T_J = +25^\circ\text{C}$, $PA_V_S = 16\text{ V}$, $V_{AVDD} = V_{DVDD} = 3.3\text{ V}$, and PA_ISET (pin 46) connected to ground, unless otherwise noted.

PARAMETER	CONDITIONS	AFE030			UNIT
		MIN	TYP	MAX	
REF1 (Pin 19)					
Bias voltage		PA_V _S /2			V
R _I	Input resistance	4			kΩ
Turn-on time	Noise-reducing capacitor = 1 nF from pin 19 to ground	20			ms
Turn-off time	Noise-reducing capacitor = 1 nF from pin 19 to ground	20			ms
REF2 (Pin 28)					
Bias voltage		V _{AVDD} /2			V
R _I	Input resistance	4			kΩ
Turn-on time	Noise-reducing capacitor = 1 μF from pin 28 to ground	20			ms
Turn-off time	Noise-reducing capacitor = 1 μF from pin 28 to ground	20			ms

ELECTRICAL CHARACTERISTICS: Power Supply

At $T_J = +25^\circ\text{C}$, $PA_V_S = 16\text{ V}$, $V_{AVDD} = V_{DVDD} = 3.3\text{ V}$, and PA_ISET (pin 46) connected to ground, unless otherwise noted.

PARAMETER	CONDITIONS	AFE030			UNIT
		MIN	TYP	MAX	
OPERATING SUPPLY RANGE					
PA_V _S	Power amplifier supply voltage	+7		+24	V
DV _{DD}	Digital supply voltage	+3.0		+3.6	V
AV _{DD}	Analog supply voltage	+3.0		+3.6	V
QUIESCENT CURRENT SD pin low					
I _{QPA_VS}	Power amplifier current	I _O = 0, PA = On ⁽¹⁾	40	55	mA
		I _O = 0, PA = Off ⁽²⁾	10		μA
I _{QDVDD}	Digital supply current	Tx configuration ⁽³⁾	1.2		mA
		Rx configuration ⁽⁴⁾	5		μA
		All blocks disabled ⁽⁵⁾	5		μA
I _{QAVDD}	Analog supply current	Tx configuration ⁽³⁾	2.8	3.7	mA
		Rx configuration ⁽⁴⁾	3.6	5.3	mA
		All blocks disabled ⁽⁵⁾	30		μA
SHUTDOWN (SD)					
PA_V _S	Power amplifier supply voltage	SD pin high	75	150	μA
DV _{DD}	Digital supply voltage	SD pin high	5	10	μA
AV _{DD}	Analog supply voltage	SD pin high	15	40	μA
TEMPERATURE					
	Specified range		-40	+125	°C

(1) Enable1 Register = 00100011, Enable2 Register = 00001110.

(2) Enable1 Register = 00000100, Enable2 Register = 00000110.

(3) In the Tx configuration, the following blocks are enabled: DAC, Tx, PA, REF1, and REF2. All other blocks are disabled. Enable1 Register = 00100011, Enable2 Register = 00001110.

(4) In the Rx configuration, the following blocks are enabled: Rx, REF1, and REF2. All other blocks are disabled. Enable1 Register = 00000100, Enable2 Register = 00000110.

(5) Enable1 Register = 00000000, Enable2 Register = 00000000.

THERMAL INFORMATION

THERMAL METRIC ⁽¹⁾		AFE030	UNITS
		RGZ (QFN)	
		48 PINS	
θ_{JA}	Junction-to-ambient thermal resistance	27.8	°C/W
θ_{JCTop}	Junction-to-case (top) thermal resistance	12.1	
θ_{JB}	Junction-to-board thermal resistance	7.5	
ψ_{JT}	Junction-to-top characterization parameter	0.4	
ψ_{JB}	Junction-to-board characterization parameter	7.4	
θ_{JCbott}	Junction-to-case (bottom) thermal resistance	1.7	

(1) For more information about traditional and new thermal metrics, see the *IC Package Thermal Metrics* application report, [SPRA953](#).

PARAMETER MEASUREMENT INFORMATION

TIMING REQUIREMENTS

SPI TIMING REQUIREMENTS

PARAMETER	CONDITION	MIN	TYP	MAX	UNIT
Input capacitance			1		pF
Input rise/fall time	t_{RFI} \overline{CS} , DIN, SCLK			2	ns
Output rise/fall time	t_{RFO} DOUT			10	ns
\overline{CS} high time	t_{CSH} \overline{CS}	20			ns
SCLK edge to \overline{CS} fall setup time	t_{CS0}	10			ns
\overline{CS} fall to first SCLK edge setup time	t_{CSSC}	10			ns
SCLK frequency	f_{SCLK}			20	MHz
SCLK high time	t_{HI}	20			ns
SCLK low time	t_{LO}	20			ns
SCLK last edge to \overline{CS} rise setup time	t_{SCCS}	10			ns
\overline{CS} rise to SCLK edge setup time	t_{CS1}	10			ns
DIN setup time	t_{SU}	10			ns
DIN hold time	t_{HD}	5			ns
SCLK to DOUT valid propagation delay	t_{DO}			20	ns
\overline{CS} rise to DOUT forced to Hi-Z	t_{soz}			20	ns

TIMING DIAGRAMS

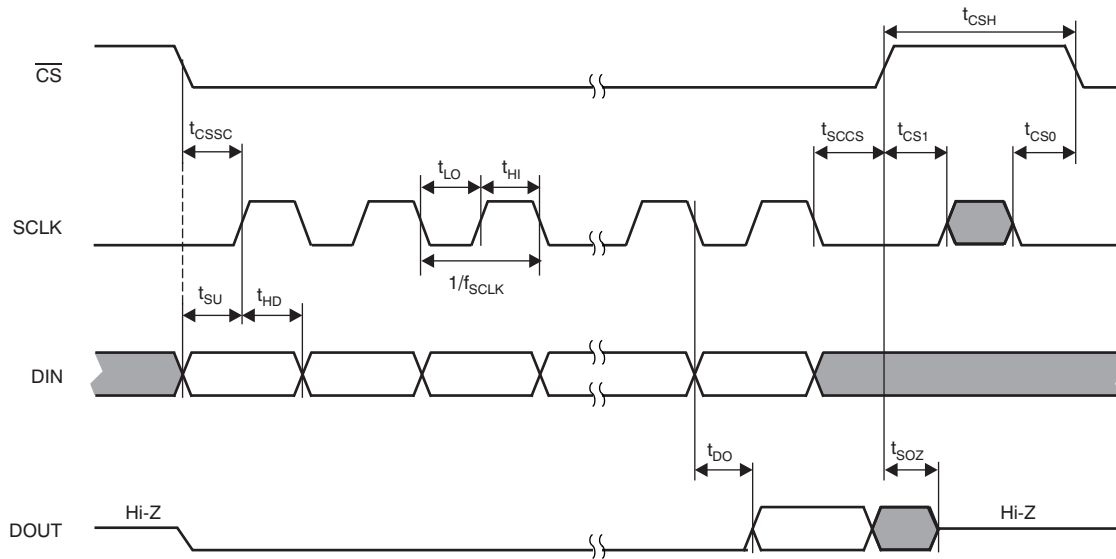

Figure 1. SPI Mode 0,0

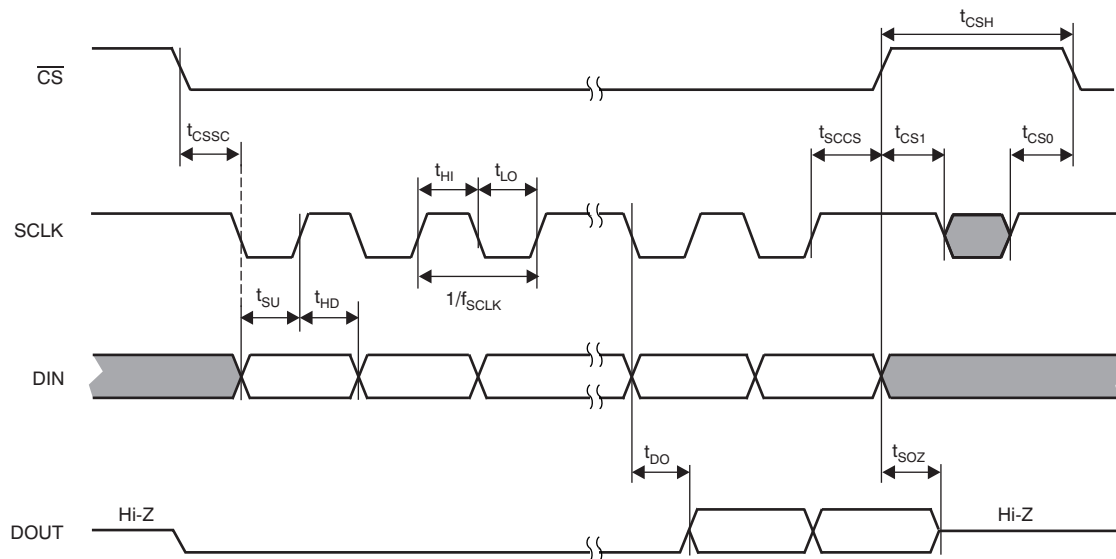
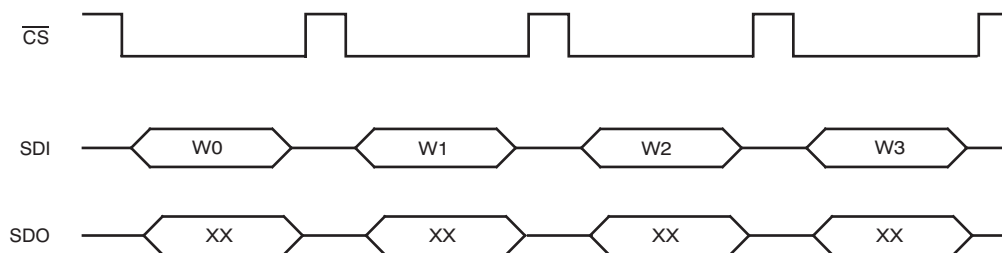

Figure 2. SPI Mode 1,1



W - Command of Write Register *N*
 XX - Don't care; undefined.

Figure 3. Write Operation in Stand-Alone Mode

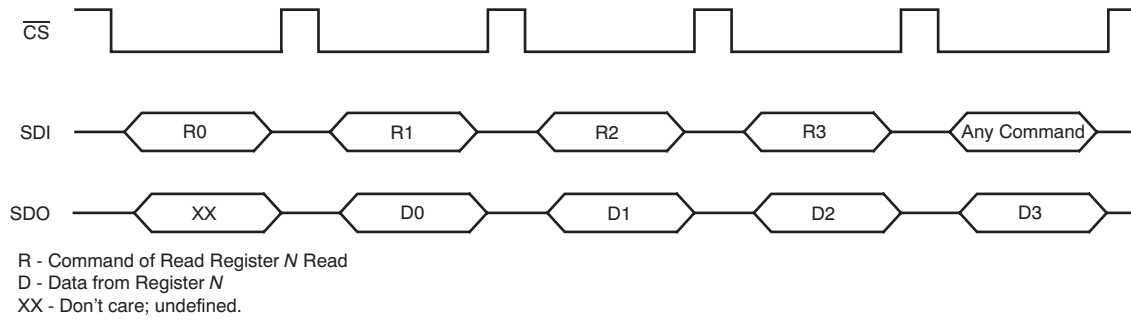
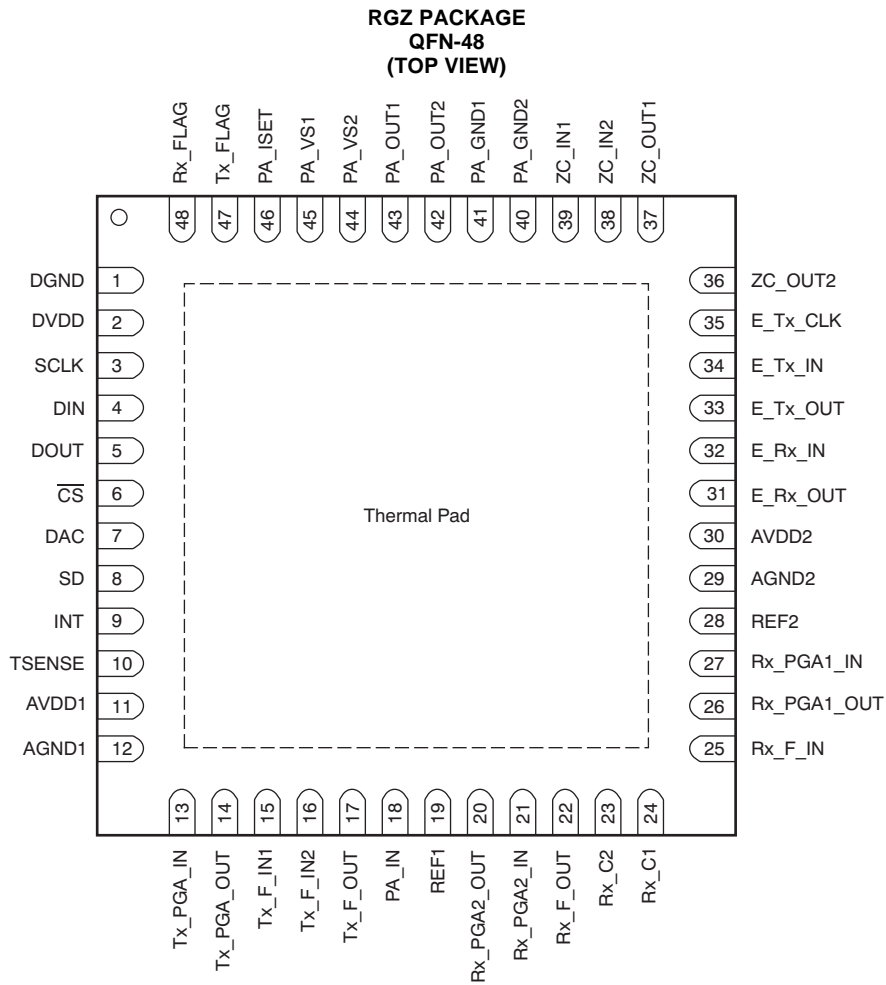

Figure 4. Read Operation in Stand-Alone Mode

PIN CONFIGURATION



NOTE: Exposed thermal pad is connected to ground.

PIN DESCRIPTIONS

AFE030		DESCRIPTION
PIN NO.	NAME	
1	DGND	Digital ground
2	DVDD	Digital supply
3	SCLK	SPI serial clock
4	DIN	SPI digital input
5	DOUT	SPI digital output
6	\overline{CS}	SPI digital chip select
7	DAC	DAC mode select
8	SD	System shutdown
9	INT	Interrupt on overcurrent or thermal limit
10	TSENSE	Temp sensing diode (anode)
11	AVDD1	Analog lupply
12	AGND1	Analog ground
13	Tx_PGA_IN	Transmit PGA Input
14	Tx_PGA_OUT	Transmit PGA loutput
15	Tx_F_IN1	Transmit filter input 1
16	Tx_F_IN2	Transmit filter input 2
17	Tx_F_OUT	Transmit filter output
18	PA_IN	Power Amplifier input
19	REF1	Power Amplifier noise reducing capacitor
20	Rx PGA2_OUT	Receiver PGA(2) output
21	Rx PGA2_IN	Receiver PGA(2) input
22	Rx_F_OUT	Receiver filter output
23	Rx_C2	Receiver external frequency select
24	Rx_C1	Receiver external frequency select
25	Rx_F_IN	Receiver filter input
26	Rx PGA1_OUT	Receiver PGA(1) output
27	Rx PGA1_IN	Receiver PGA(1) input
28	REF2	Receiver noise reducing capacitor
29	AGND2	Analog ground
30	AVDD2	Analog supply
31	E_Rx_OUT	Two-wire receiver output
32	E_Rx_IN	Two-wire receiver input
33	E_Tx_OUT	Two-wire transmitter output
34	E_Tx_IN	Two-wire transmitter input
35	E_Tx_CLK	Two-wire transmitter clock input
36	ZC_OUT2	Zero-crossing detector output
37	ZC_OUT1	Zero-crossing detector output
38	ZC_IN2	Zero-crossing detector input
39	ZC_IN1	Zero-crossing detector input
40	PA_GND2	Power amplifier ground
41	PA_GND1	Power amplifier ground
42	PA_OUT2	Power amplifier output
43	PA_OUT1	Power amplifier output
44	PA_VS2	Power amplifier supply
45	PA_VS1	Power amplifier supply
46	PA_ISET	Power amplifier current limit set
47	Tx_FLAG	Transmitter ready flag
48	Rx_FLAG	Receiver ready flag

FUNCTIONAL BLOCK DIAGRAM

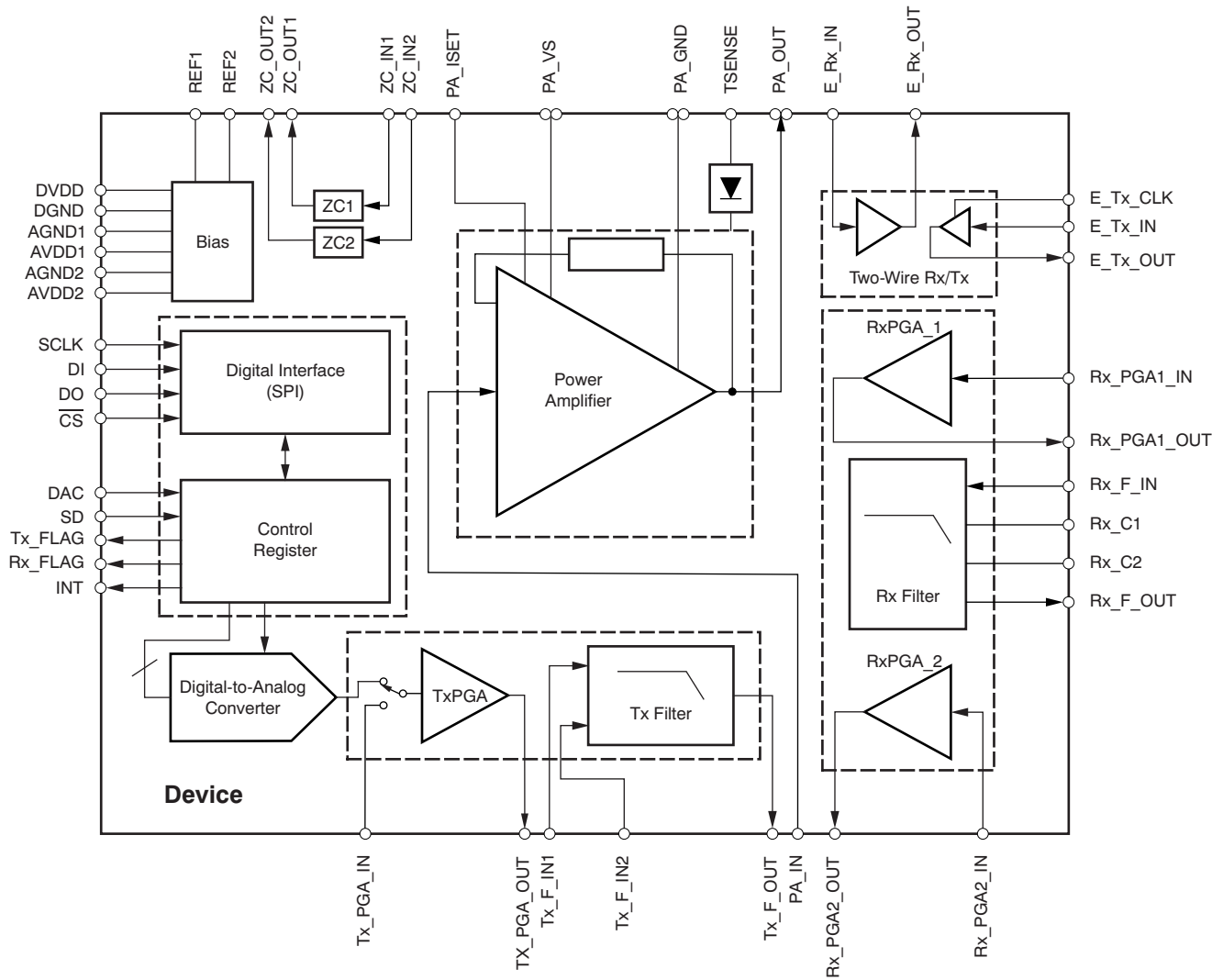

TYPICAL CHARACTERISTICS

At $T_J = +25^\circ\text{C}$, $PA_{V_S} = 16\text{ V}$, $V_{AVDD} = V_{DVDD} = 3.3\text{ V}$, and PA_{ISET} (pin 46) connected to ground, unless otherwise noted.

Tx Filter GAIN vs FREQUENCY

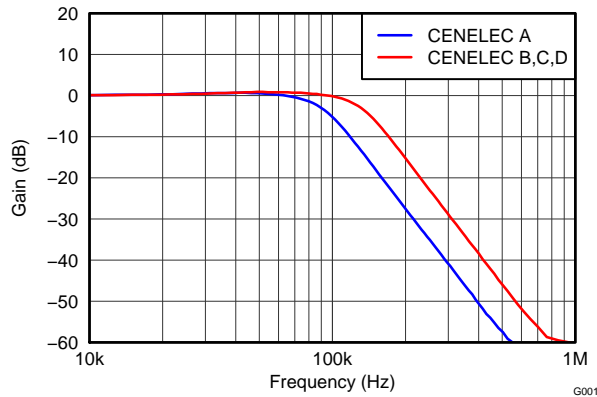

Figure 5.

Rx Filter GAIN vs FREQUENCY

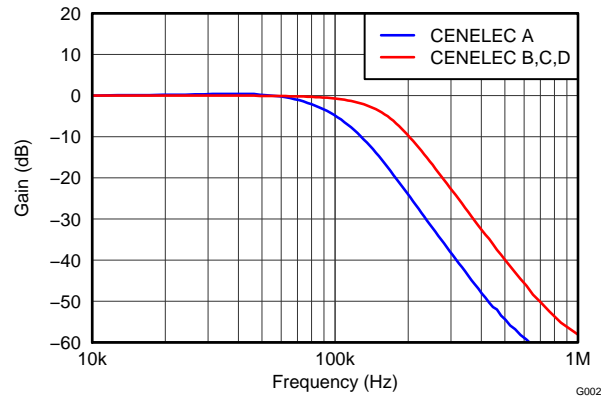

Figure 6.

PA GAIN vs FREQUENCY

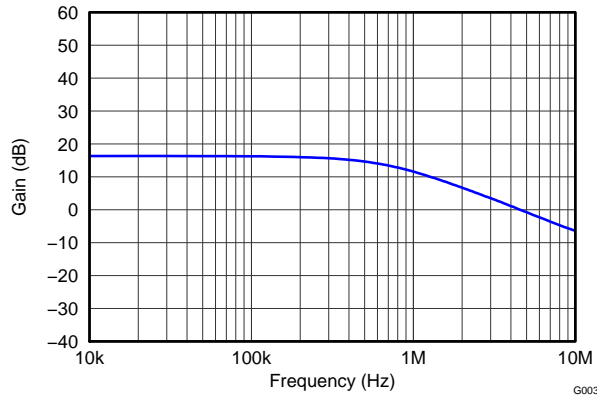

Figure 7.

MAXIMUM PA OUTPUT VOLTAGE vs FREQUENCY

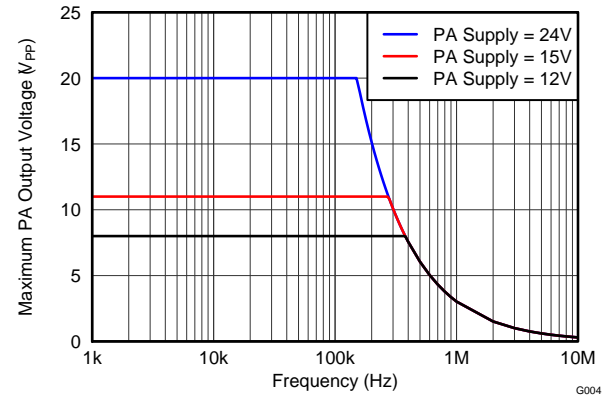

Figure 8.

Tx PGA GAIN vs FREQUENCY

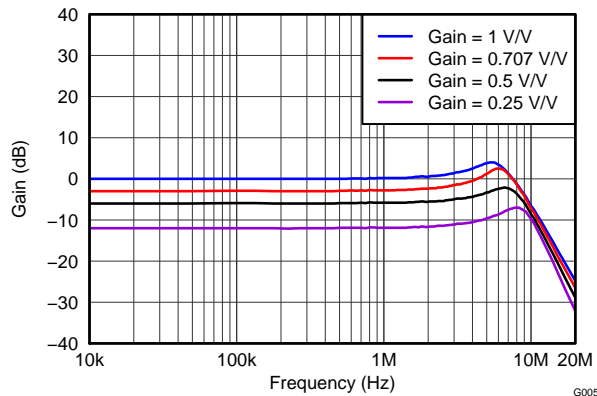

Figure 9.

Rx PGA1 GAIN vs FREQUENCY

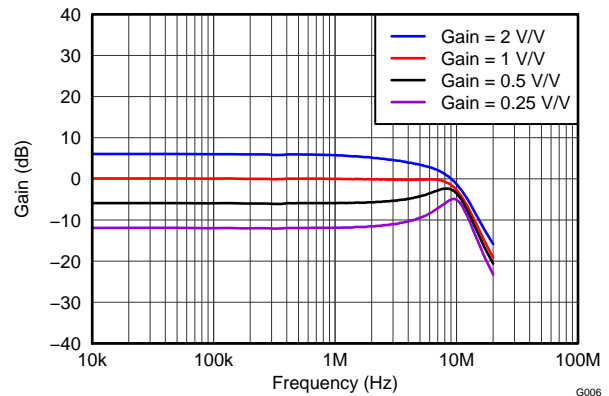

Figure 10.

TYPICAL CHARACTERISTICS (continued)

At $T_J = +25^\circ\text{C}$, $PA_V_S = 16\text{ V}$, $V_{AVDD} = V_{DVDD} = 3.3\text{ V}$, and PA_ISET (pin 46) connected to ground, unless otherwise noted.

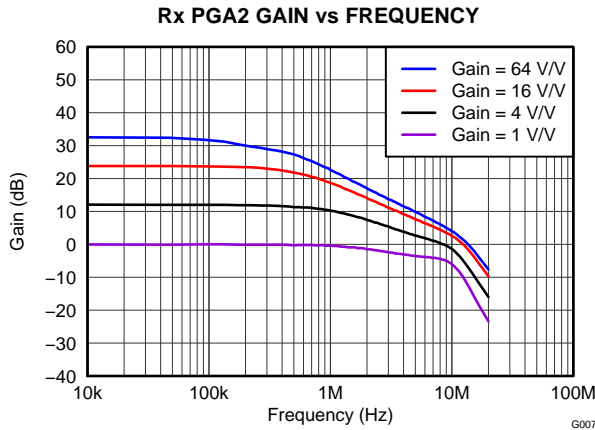

Figure 11.

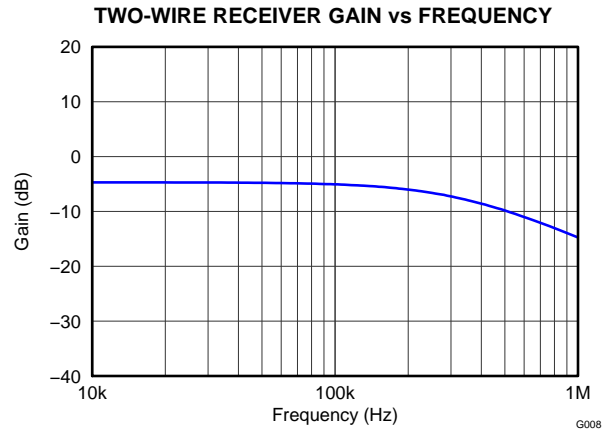

Figure 12.

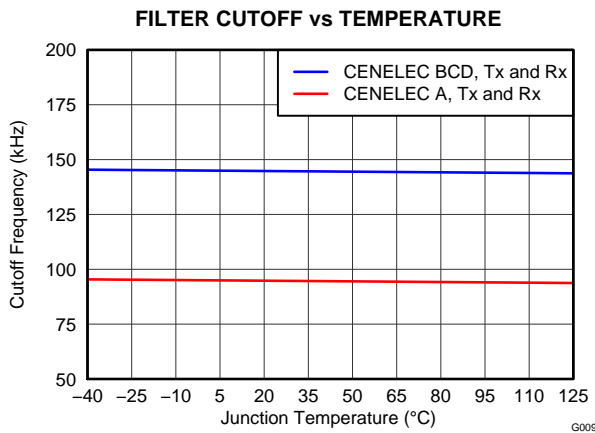

Figure 13.

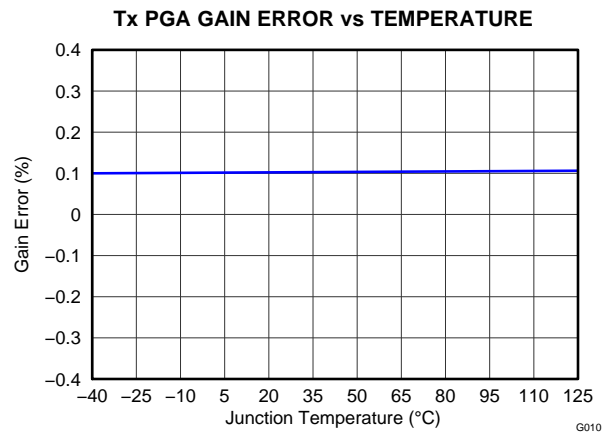

Figure 14.

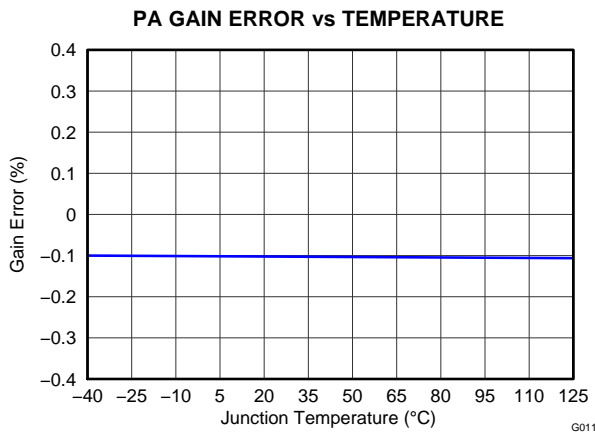

Figure 15.

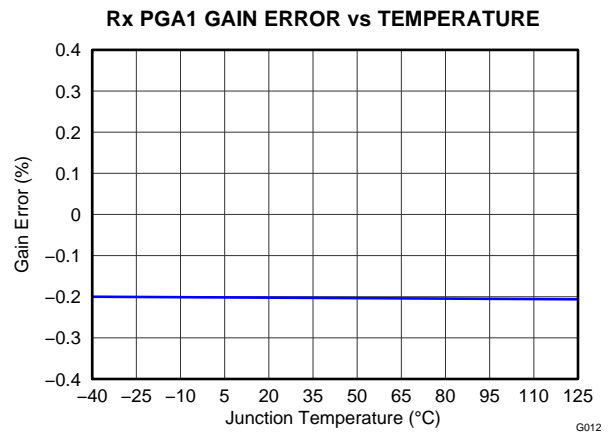

Figure 16.

TYPICAL CHARACTERISTICS (continued)

At $T_J = +25^\circ\text{C}$, $PA_V_S = 16\text{ V}$, $V_{AVDD} = V_{DVDD} = 3.3\text{ V}$, and PA_ISET (pin 46) connected to ground, unless otherwise noted.

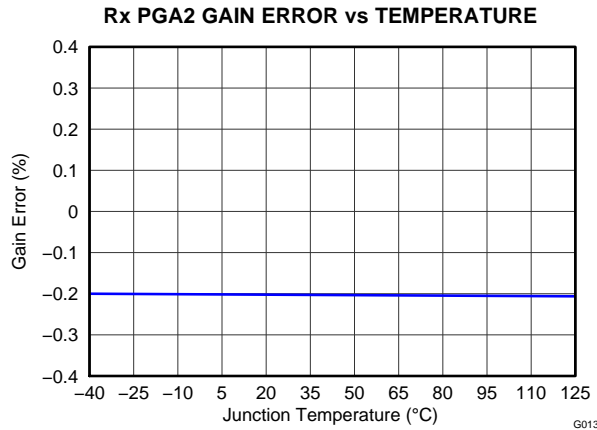

Figure 17.

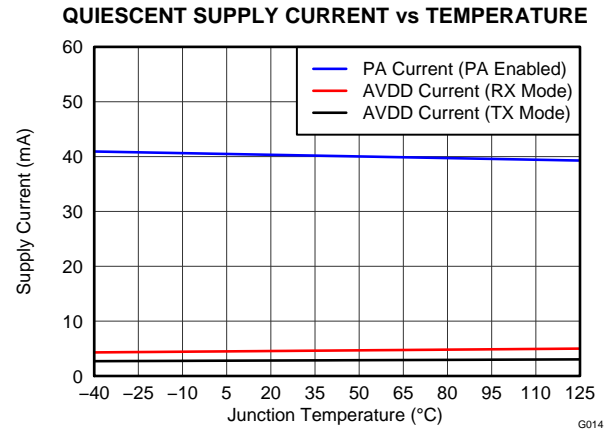

Figure 18.

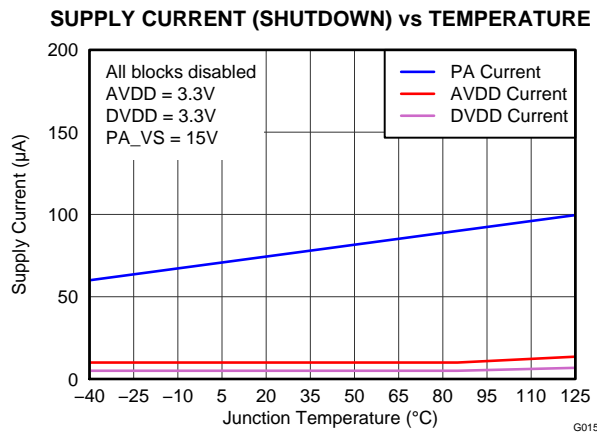

Figure 19.

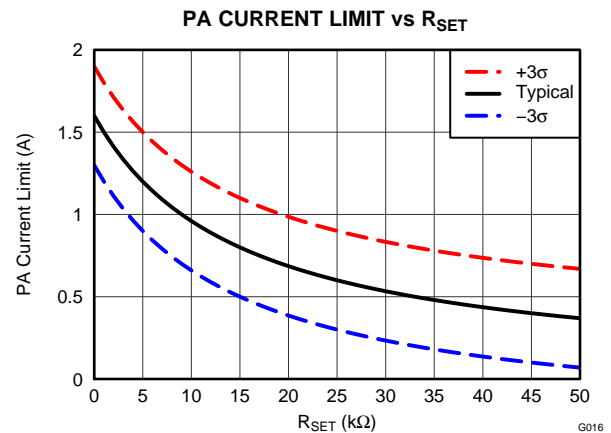

Figure 20.

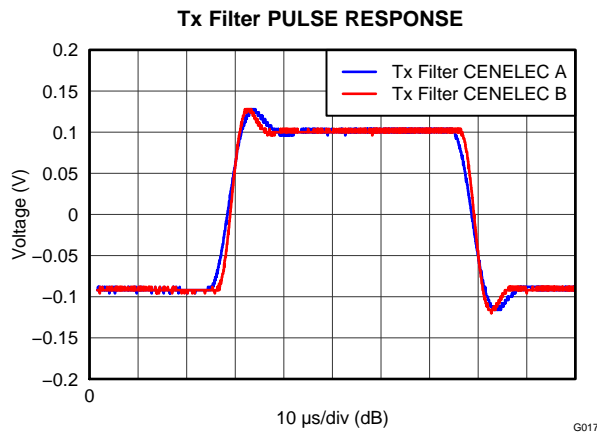

Figure 21.

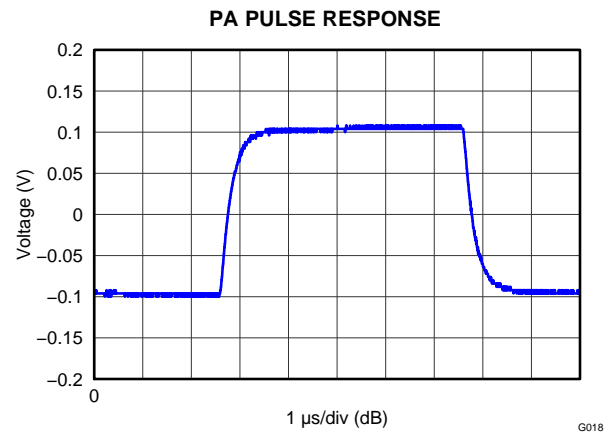
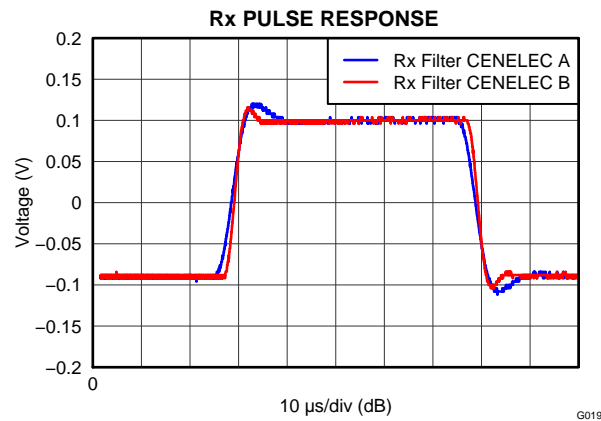

Figure 22.

TYPICAL CHARACTERISTICS (continued)

At $T_J = +25^\circ\text{C}$, $PA_{V_S} = 16\text{ V}$, $V_{AVDD} = V_{DVDD} = 3.3\text{ V}$, and PA_{ISET} (pin 46) connected to ground, unless otherwise noted.



APPLICATION INFORMATION

GENERAL DESCRIPTION

The AFE030 is an integrated powerline communication analog front-end (AFE) device built from a variety of functional blocks that work in conjunction with a microcontroller. The AFE030 provides the interface between the microcontroller and a line coupling circuit. The AFE030 delivers high performance and is designed to work with a minimum number of external components. Consisting of a variety of functional and configurable blocks, the AFE030 simplifies design efforts and reduces the time to market of many applications.

The AFE030 includes three primary functional blocks:

- Power Amplifier (PA)
- Transmitter (Tx)
- Receiver (Rx)

The AFE030 also consists of other support circuitry blocks that provide zero crossing detection, an additional two-wire communications channel, and power-saving biasing blocks (see the [Functional Block Diagram](#)). All of these functional blocks are digitally controlled by the microcontroller through the serial interface (SPI).

[Figure 24](#) shows a typical powerline communications application system diagram. [Table 1](#) is a complete list of the sections within the AFE030.

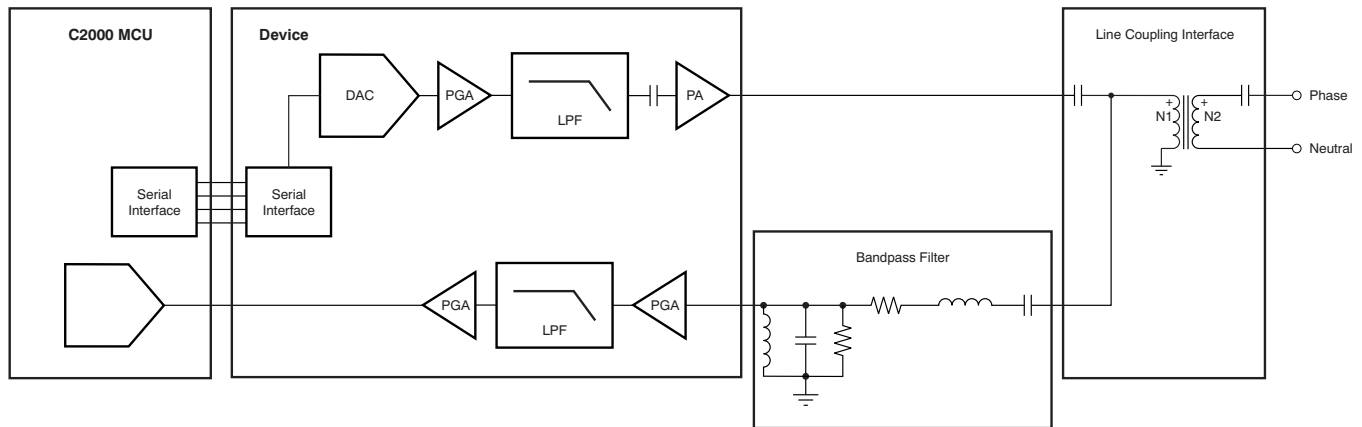

Figure 24. Typical Powerline Communications System Diagram

Table 1. Block Descriptions

BLOCK	DESCRIPTION
PA	The PA block includes the power amplifier and associated pedestal biasing circuitry
Tx	The Tx block includes the Tx_Filter and the Tx_PGA
Rx	The Rx block includes the Rx PGA1, the Rx Filter, and the Rx PGA2
ERx	The ER block includes the two-wire receiver
ETx	The ETx block includes the two-wire transmitter
DAC	The DAC block includes a digital-to-analog converter
ZC	The ZC block includes both zero crossing detectors
REF1	The REF1 block includes the internal bias generator for the PA block
REF2	The REF2 block includes the internal bias generators for the Tx, Rx, ERx, and ETx blocks

BLOCK DESCRIPTIONS

PA Block

The Power Amplifier (PA) block consists of a high slew rate, high-voltage, and high-current operational amplifier. The PA is configured with an inverting gain of 6.5 V/V, has a low-pass filter response, and maintains excellent linearity and low distortion. The PA is specified to operate from 7 V to 26 V and can deliver up to ± 1.0 A of continuous output current over the specified junction temperature range of -40°C to $+125^{\circ}\text{C}$. Figure 25 illustrates the PA block.

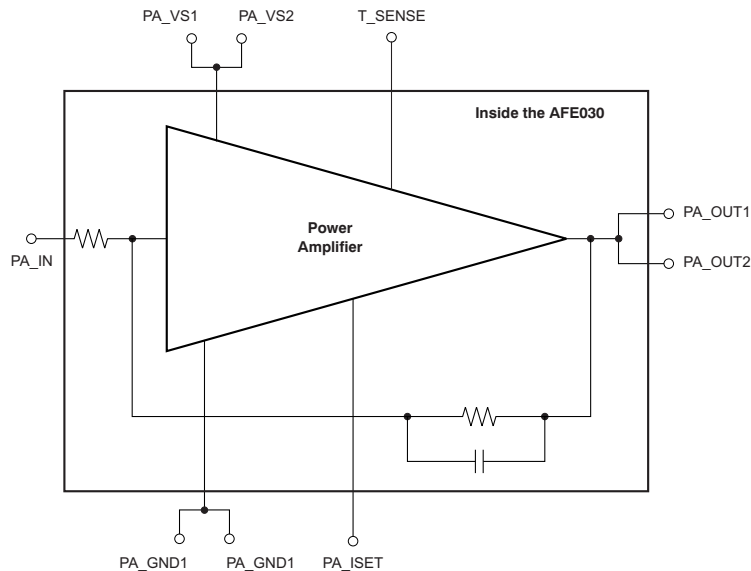

Figure 25. PA Block Equivalent Circuit

Connecting the PA in a typical PLC application requires only two additional components: an ac coupling capacitor, C_{IN} , and the current limit programming resistor, R_{SET} . Figure 26 shows the typical connections to the PA block.

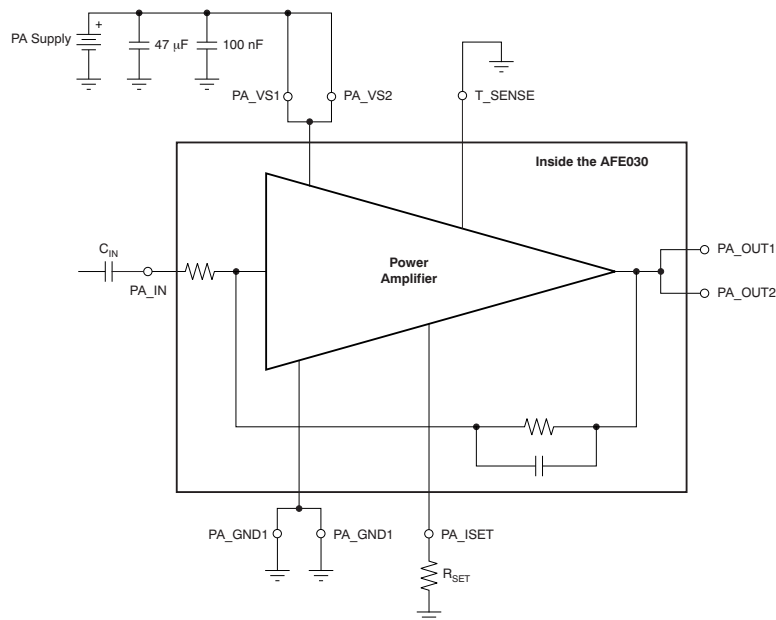

Figure 26. Typical Connections to the PA

The external capacitor, C_{IN} , introduces a single-pole, high-pass characteristic to the PA transfer function; combined with the inherent low-pass transfer function, this characteristic results in a passband response. The value of the high-pass cutoff frequency is determined by C_{IN} reacting with the input resistance of the PA circuit, and can be found from [Equation 1](#):

$$C_{IN} = \frac{1}{(2 \times \pi \times 20 \text{ k}\Omega \times f_{HP})} \quad (1)$$

Where:

- C_{IN} = external input capacitor
- f_{HP} = desired high-pass cutoff frequency

For example, setting C_{IN} to 3.3 nF results in a high-pass cutoff frequency of 2.4 kHz. The voltage rating for C_{IN} should be determined to withstand operation up to the PA power-supply voltage.

When the transmitter is not in use, the output can be disabled and placed into a high-impedance state by writing a '0' to the PA-OUT bit in the [Enable2 Register](#). Additional power savings can be realized by shutting down the PA when not in use. Shutting down the PA for power savings is accomplished by writing a '0' to the PA bit in the [Enable1 Register](#). Shutting down the PA also results in the PA output entering a high-impedance state. When the PA shuts down, it consumes only 2 mW of power.

The PA_ISET pin (pin 46) provides a resistor-programmable output current limit for the PA block. [Equation 2](#) determines the value of the external R_{SET} resistor attached to this pin.

$$R_{SET} = \left(20 \text{ k} \times \frac{1.2 \text{ V}}{I_{LIM}} \right) - 15 \text{ k}\Omega \quad (2)$$

Where:

- R_{SET} = the value of the external resistor connected between pin 46 and ground.
- I_{LIM} = the value of the desired current limit for the PA.

Note that to ensure proper design margin with respect to manufacturing and temperature variations, a 30% increase in the value used in [Equation 2](#) for I_{LIM} over the nominal value of I_{LIM} is recommended. See [Figure 20, PA Current Limit vs \$R_{SET}\$](#) . For maximum output current, PA_ISET (pin 46) may be connected directly to ground.

Tx Block

The Tx block consists of the Tx PGA and Tx Filter. The Tx PGA is a low-noise, high-performance, programmable gain amplifier. In DAC mode (where pin 7 is a logical '1' and [Enable1 Register](#) bit location 5 is a logical '1'), the Tx PGA operates as the internal digital-to-analog converter (DAC) output buffer with programmable gain. In PWM mode (where pin 7 is a logical '0' and [Enable1 Register](#) bit location 5 is a logical '0'), the Tx PGA operates as a stand-alone programmable gain amplifier. The Tx PGA gain is programmed through the serial interface. The Tx PGA gain settings are 0.25 V/V, 0.5 V/V, 0.707 V/V, and 1 V/V.

The Tx Filter is a unity-gain, fourth-order low-pass filter. The Tx Filter cutoff frequency is selectable between CENELEC A or CENELEC B, C, and D modes. The [Control1 Register](#) bit location 3 setting (CA CBCD) determines the cutoff frequency. Setting Control1 Register bit location 3 to '0' selects the CENELEC A band; setting Control1 Register bit location 3 to '1' selects CENELEC B, C, and D bands.

The AFE030 supports both DAC inputs or PWM inputs for the Tx signal path. DAC mode is recommended for best performance. In DAC mode, no external components in the Tx signal path are required to meet regulatory signal emissions requirements. When in DAC mode, the AFE030 accepts serial data from the microprocessor and writes that data to the internal DAC registers. When in DAC mode (where pin 7 is a logical '1' and [Enable1 Register](#) bit location 5 is a logical '1'), the Tx PGA output must be directly coupled to the Tx_FIN1 input and the unused Tx_FIN2 input must be grounded.

The proper connections for the Tx signal path for DAC mode operation are shown in [Figure 27](#). Operating in DAC mode results in the lowest distortion signal injected onto the ac mains. No additional external filtering components are required to meet CENELEC requirements for A, B, C or D bands when operating in DAC mode.

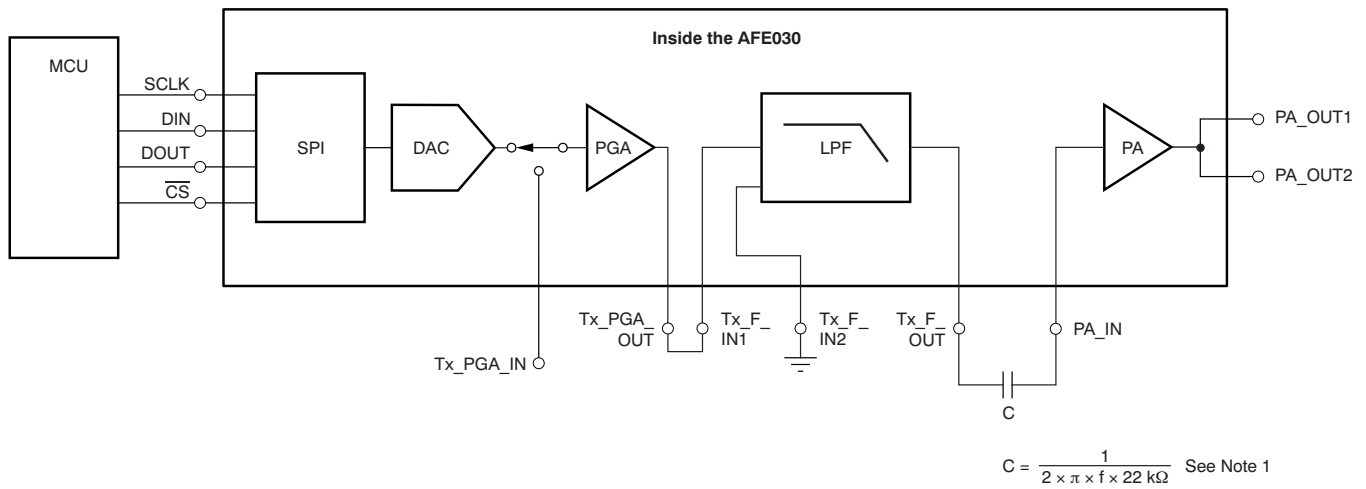

(1) For capacitor value C , f is the desired lower cutoff frequency and 22 k Ω is the PA input resistance.

Figure 27. Recommended Tx Signal Chain Connections Using DAC Mode

In PWM mode (where pin 7 is a logical '0' and [Enable1 Register](#) bit location 5 is a logical '0'), the microprocessor general-purpose input/output (GPIO) can be connected directly to either one of the Tx Filter inputs; the unused input should remain unconnected. A lower distortion PWM signal generated from two PWM signals shifted in phase by 90 degrees can be also be input to the Tx Filter through the use of both inputs. [Figure 28](#) and [Figure 29](#) show the proper connections for single PWM and dual PWM operating modes, respectively.

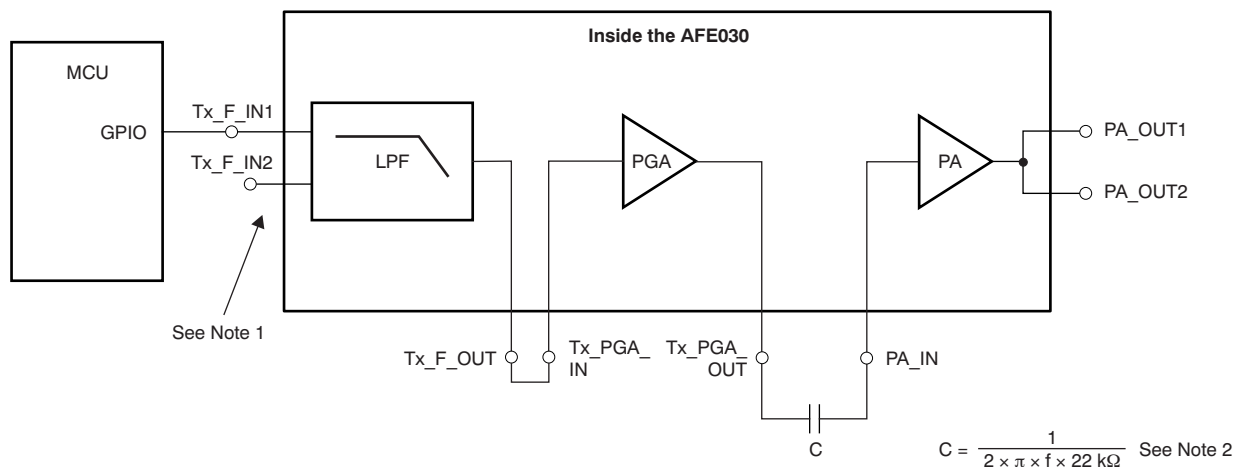

(1) Leave unused Tx Filter input unconnected.

(2) For capacitor value C , f is the desired lower cutoff frequency and 22 k Ω is the PA input resistance.

Figure 28. Recommended Tx Signal Chain Connections in PWM Mode Using One PWM Signal

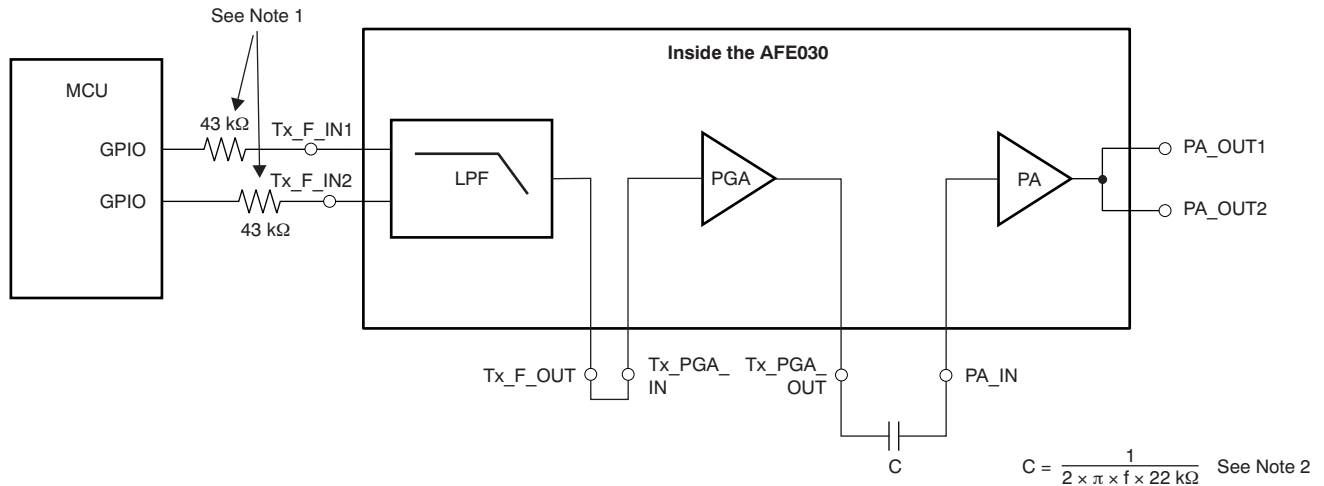

(1) When using both Tx Filter inputs, use 43-kΩ resistors to match the input resistance for best frequency response.

(2) For capacitor value C , f is the desired lower cutoff frequency and 22 kΩ is the PA input resistance.

Figure 29. Recommended Tx Signal Chain Connections in PWM Mode Using Two PWM Signals

In PWM mode, there is inherently more distortion from the PWM signal than from the internal DAC. To achieve the best results in PWM mode, add passive RC filters to increase the low-pass filtering. Figure 30 and Figure 31 illustrate the recommended locations of these RC filters.

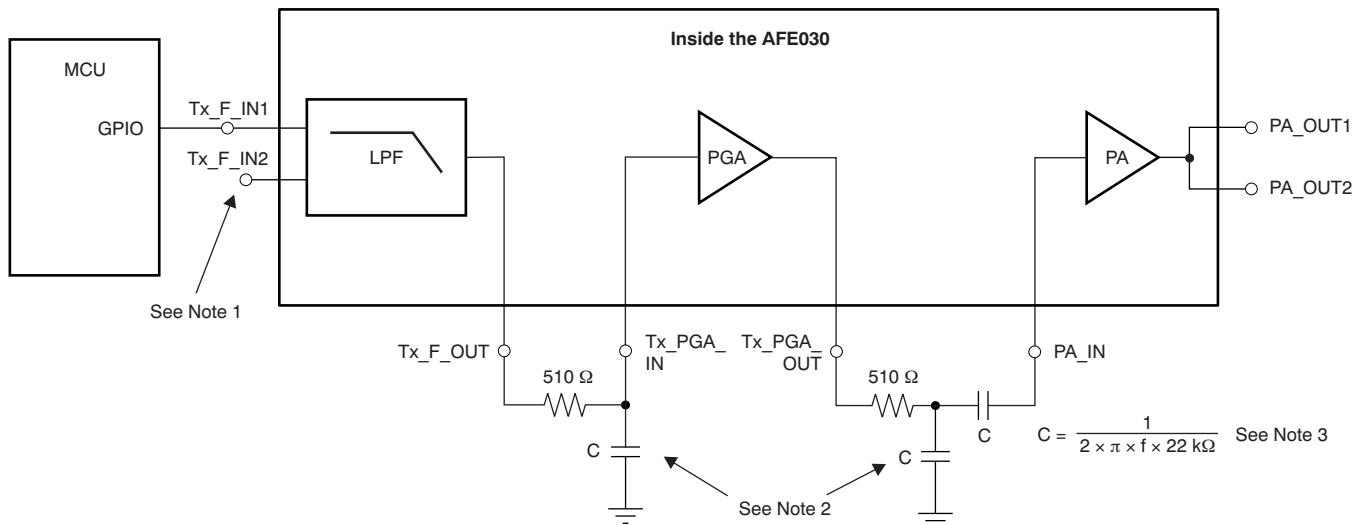

(1) Leave unused Tx Filter input unconnected.

(2) Refer to Table 2.

(3) For capacitor value C , f is the desired lower cutoff frequency and 22 kΩ is the PA input resistance.

Figure 30. Recommended Tx Signal Chain Connections in PWM Mode Using One PWM Signal and Additional RC Filters

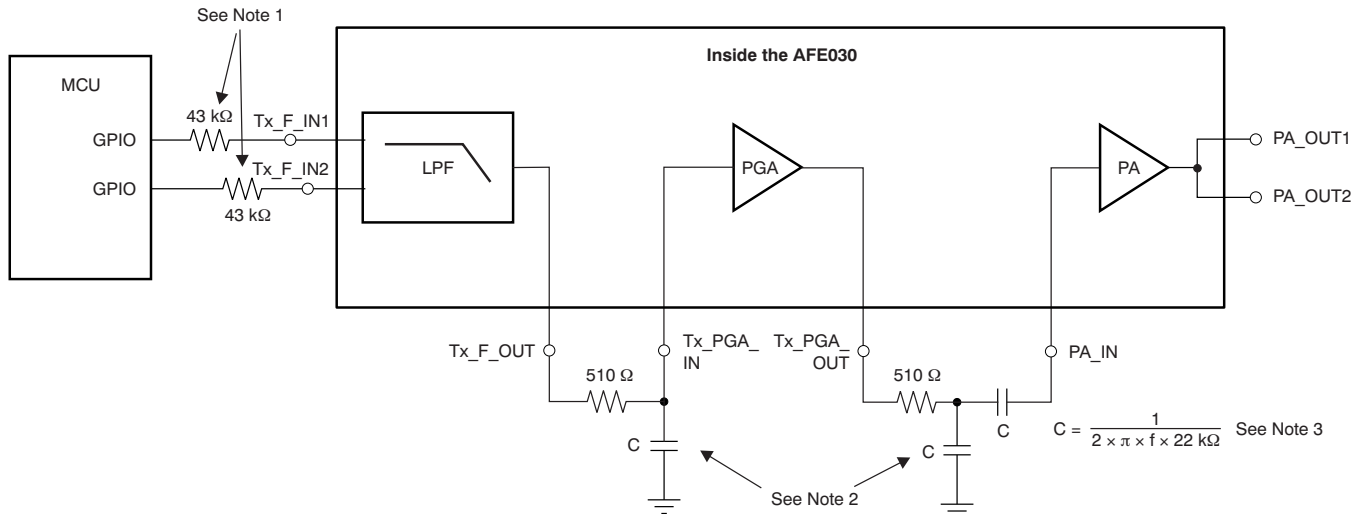

(1) When using both Tx Filter inputs, use 43-kΩ resistors to match the input resistance for best frequency response.

(2) Refer to [Table 2](#).

(3) For capacitor value C , f is the desired lower cutoff frequency and 22 kΩ is the PA input resistance.

Figure 31. Recommended Tx Signal Chain Connections in PWM Mode Using Two PWM Signals and Additional RC Filters

For the capacitors listed in [Table 2](#), it is recommended that these components be rated to withstand the full AV_{DD} power-supply voltage.

Table 2. Recommended External R and C Values to Increase Tx Filter Response Order in PWM Applications

FREQUENCY BAND	R (Ω)	C (nF)
SFSK: 63 kHz, 74 kHz	510	2.7
CENELEC A	510	1.5
CENELEC B, C, D	510	1

The Tx PGA and Tx Filter each have the inputs and outputs externally available in order to provide maximum system design flexibility. Care should be taken when laying out the PCB traces from the inputs or outputs to avoid excessive capacitive loading. Keeping the PCB capacitance from the inputs to ground, or from the outputs to ground, less than 100 pF is recommended.

Rx Block

The Rx block consists of Rx PGA1, the Rx Filter, and Rx PGA2. Both Rx PGA1 and Rx PGA2 are high-performance programmable gain amplifiers. Rx PGA1 can be configured through the SPI to operate as either an attenuator or in gain. The gain steps of the Rx PGA1 are 0.25 V/V, 0.5 V/V, 1 V/V, and 2 V/V. The gain steps of the Rx PGA2 are 1 V/V, 4 V/V, 16 V/V, and 64 V/V. Configuring the Rx PGA1 as an attenuator (at gains less than 1 V/V) is useful for applications where the presence of large interference signals are present within the signal band. Attenuating the large interference allows these signals to pass through the analog Rx signal chain without causing an overload; the interference signal can then be processed and removed within the microprocessor as necessary.

The Rx Filter is a very low noise, unity-gain, fourth-order low-pass filter. The Rx Filter cutoff frequency is selectable between CENELEC A or CENELEC B, C, and D modes. The **Control1 Register** bit location 3 setting (CA CBCD) determines the cutoff frequency. Setting **Control1 Register** bit location 3 to '0' selects the CENELEC A band; setting **Control1 Register** bit location 3 to '1' selects the CENELEC B, C, and D bands. Because the Rx Filter is a very low noise analog filter, two external capacitors are required to properly configure the Rx Filter. **Table 3** shows the proper capacitance values for CENELEC A, B, C, and D bands. Capacitor Rx C1 is connected between pin 24 and ground, and Rx C2 is connected between pin 23 and ground. For the capacitors shown, it is recommended that these components be rated to withstand the full AV_{DD} power-supply voltage

Table 3. Recommended External Capacitors Required for Rx Filter

FREQUENCY BAND	Rx C1, PIN 24	Rx C2, PIN 23	CUTOFF FREQUENCY (kHz)
CENELEC A	680 pF	680 pF	90
CENELEC B, C, D	270 pF	560 pF	145

Figure 32 illustrates the recommended connections for the Rx signal chain.

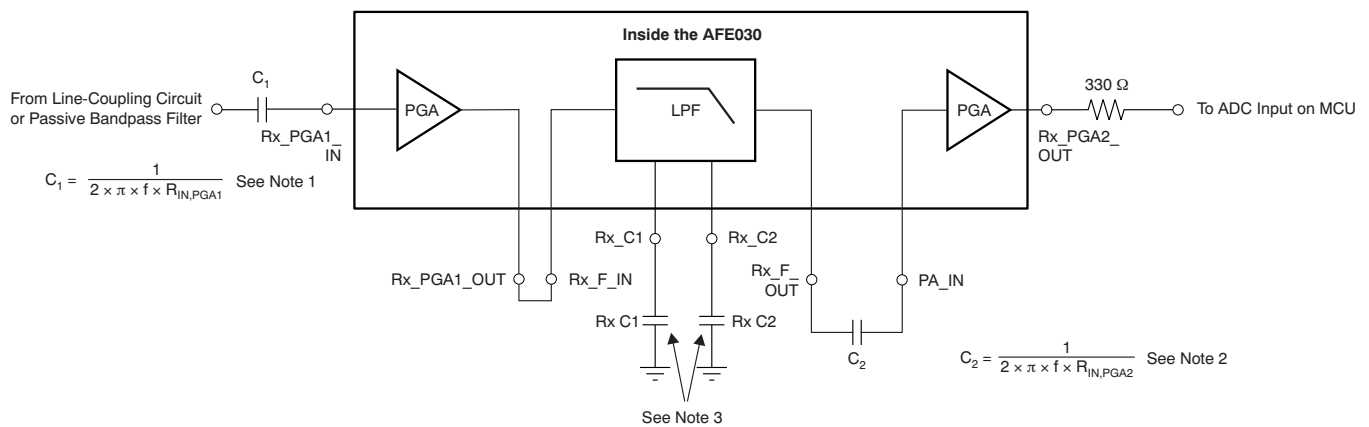

- (1) For capacitor value C_1 , f is the desired lower cutoff frequency and $R_{IN,PGA1}$ is the input resistance of Rx PGA1.
- (2) For capacitor value C_2 , f is the desired lower cutoff frequency and $R_{IN,PGA2}$ is the input resistance of Rx PGA2.
- (3) Refer to **Table 3**.

Figure 32. Recommended Connections for Rx Signal Chain

As **Figure 33** shows, a fourth-order passive passband filter is optional but recommended for applications where high performance is required. The external passive passband filter removes any unwanted, out-of-band signals from the signal path, and prevents them from reaching the active internal filters within the AFE030.

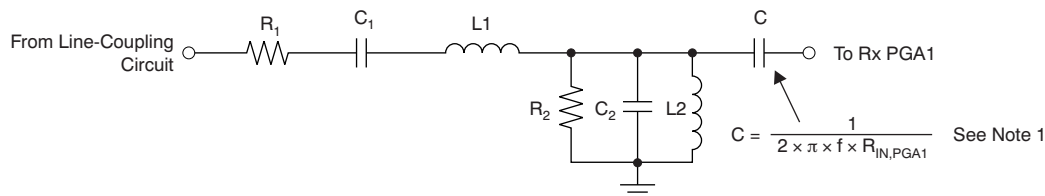

- (1) For capacitor value C , f is the desired lower cutoff frequency and $R_{IN,PGA1}$ is the input resistance of Rx PGA1. Refer to **Table 3**.

Figure 33. Passive Bandpass Rx Filter

The following steps can be used to quickly design the passive passband filter. (Note that these steps produce an approximate result.)

1. Choose the filter characteristic impedance, Z_C :
 - For –6-dB passband attenuation: $R_1 = R_2 = Z_C$
 - For 0-dB passband attenuation: $R_1 = Z_C$, $R_2 = 10 \times Z_C$
2. Calculate values for C_1 , C_2 , L_1 , and L_2 using the following equations:

$$C_1 = \frac{1}{(2 \times \pi \times f_1 \times Z_C)}$$

$$C_2 = \frac{1}{(2 \times \pi \times f_2 \times Z_C)}$$

$$L_1 = \frac{Z_C}{(2 \times \pi \times f_2)}$$

$$L_2 = \frac{Z_C}{(2 \times \pi \times f_1)}$$

Table 4 and Table 5 shows standard values for common applications.

Table 4. Recommended Component Values for Fourth-Order Passive Bandpass Filter (0-dB Passband Attenuation)

FREQUENCY BAND	FREQUENCY RANGE (kHz)	CHARACTERISTIC IMPEDANCE (Ω)	R1 (Ω)	R2 (Ω)	C1 (nF)	C2 (nF)	L1 (μ H)	L2 (μ H)
CENELEC A	35 to 95	1k	1k	10k	4.7	1.5	1500	4700
CENELEC B, C, D	95 to 150	1k	1k	10k	1.7	1	1200	1500
SFSK	63 to 74	1k	1k	10k	2.7	2.2	2200	2200

Table 5. Recommended Component Values for Fourth-Order Passive Bandpass Filter (–6-dB Passband Attenuation)

FREQUENCY BAND	FREQUENCY RANGE (kHz)	CHARACTERISTIC IMPEDANCE (Ω)	R1 (Ω)	R2 (Ω)	C1 (nF)	C2 (nF)	L1 (μ H)	L2 (μ H)
CENELEC A	35 to 95	1k	1k	1k	4.7	1.5	1500	4700
CENELEC B, C, D	95 to 150	1k	1k	1k	1.7	1	1200	1500
SFSK	63 to 74	1k	1k	1k	2.7	2.2	2200	2200

The Rx PGA1, Rx Filter, and Rx PGA2 components have all inputs and outputs externally available to provide maximum system design flexibility. Care should be taken when laying out the PCB traces from the inputs or outputs to avoid excessive capacitive loading. Keeping the PCB capacitance from the inputs to ground, or outputs to ground, below 100 pF is recommended.

Figure 34 shows the complete Rx signal path, including the optional passive passband filter.

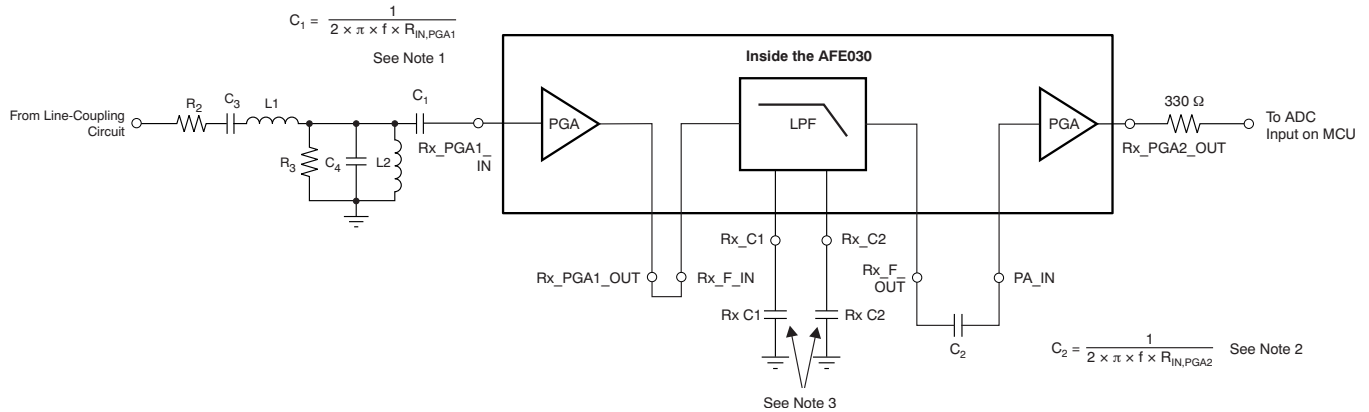

- (1) For capacitor value C_1 , f is the desired lower cutoff frequency and $R_{IN,PGA1}$ is the input resistance of Rx PGA1.
- (2) For capacitor value C_2 , f is the desired lower cutoff frequency and $R_{IN,PGA2}$ is the input resistance of Rx PGA2.
- (3) Refer to Table 3.

Figure 34. Complete Rx Signal Path (with Optional Bandpass Filter)

DAC Block

The DAC block consists only of the 10-bit DAC. The use of the DAC is recommended for best performance. The serial interface is used to write directly to the DAC registers when the DAC pin (pin 7) is driven high. Placing the DAC pin into a high state configures the SPI for direct serial interface to the DAC. Use the following sequence to write to the DAC:

- Set \overline{CS} low.
- Set the DAC pin (pin 7) high.
- Write a 10-bit word to DIN. The DAC register is left-justified and truncates more than 10 bits.
- \overline{CS} high updates the DAC.

Refer to [Figure 35](#) for an illustration of this sequence.

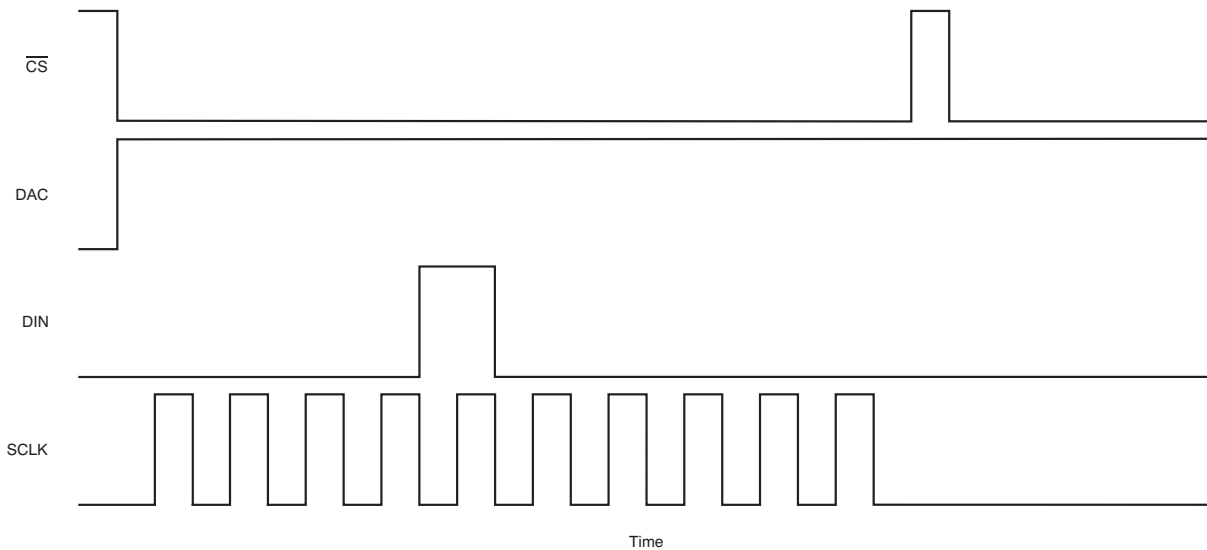

Figure 35. Writing to the DAC Register

[Table 6](#) lists the DAC Register configurations.

Table 6. DAC Registers

DAC PIN HIGH: DAC REGISTER <15:0>	LOCATION (0 = LSB)	DEFAULT	R/W	FUNCTION
DAC<0>	0	—	W	Truncated
DAC<1>	1	—	W	Truncated
DAC<2>	2	—	W	Truncated
DAC<3>	3	—	W	Truncated
DAC<4>	4	—	W	Truncated
DAC<5>	5	—	W	Truncated
DAC<6>	6	—	W	DAC bit 0 = DAC LSB
DAC<7>	7	—	W	DAC bit 1
DAC<8>	8	—	W	DAC bit 2
DAC<9>	9	—	W	DAC bit 3
DAC<10>	10	—	W	DAC bit 4
DAC<11>	11	—	W	DAC bit 5
DAC<12>	12	—	W	DAC bit 6
DAC<13>	13	—	W	DAC bit 7
DAC<14>	14	—	W	DAC bit 8
DAC<15>	15	—	W	DAC bit 9 = DAC MSB

REF1 and REF2 Blocks

The REF1 and REF2 blocks create midscale power-supply biasing points used internally to the AFE030. Each reference divides its respective power-supply voltage in half with a precision resistive voltage divider. REF1 provides a $PA_V_S/2$ voltage at the output of the PA, while REF2 provides an $AV_{DD}/2$ voltage at the outputs of the Tx PGA, Tx Filter, Rx PGA1, Rx Filter, and Rx PGA2. Each REF block has its output brought out to an external pin that can be used for filtering and noise reduction. Figure 36 and Figure 37 show the proper connections of the external noise-reducing capacitors. These capacitors are optional, but are recommended for best performance.

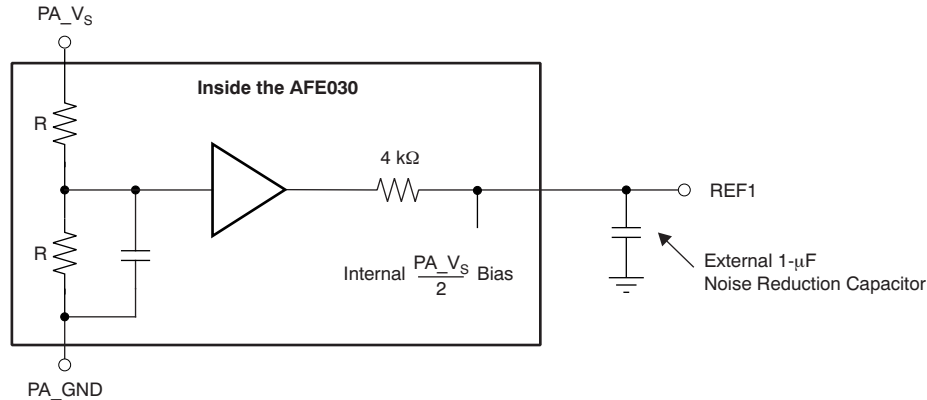

Figure 36. REF1 Functional Diagram

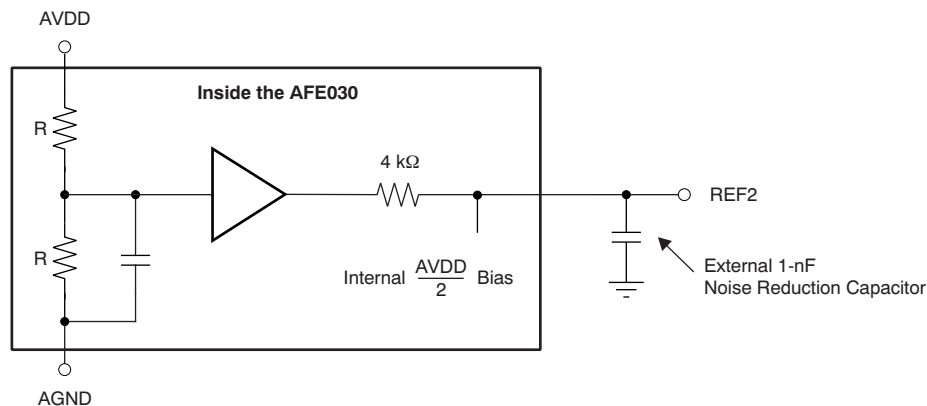

Figure 37. REF2 Functional Diagram

Zero Crossing Detector Block

The AFE030 includes two zero crossing detectors. Zero crossing detectors can be used to synchronize communications signals to the ac line or sources of noise. Typically, in single-phase applications, only a single zero crossing detector is used. In three-phase applications, both zero crossing detectors can be used; one component detects phase A, and one detects phase B. Phase C zero crossings can then be inferred from the data gathered from the other phases. [Figure 38](#) shows the AFE030 configured for non-isolated zero crossing detection.

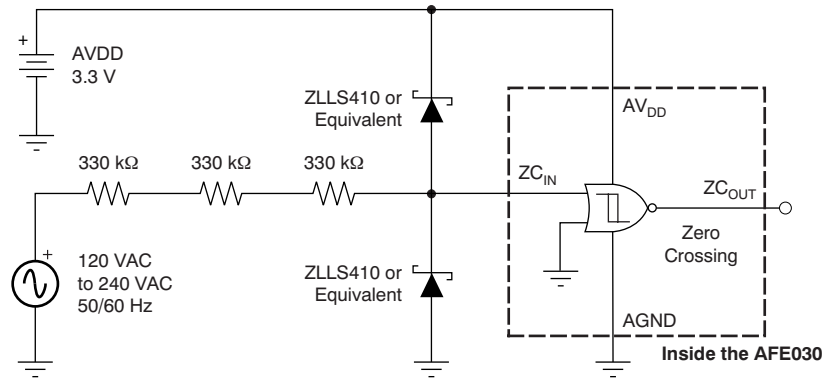

Figure 38. Non-Isolated Zero Crossing Detection Using the AFE030

Non-isolated zero crossing waveforms are shown in [Figure 39](#).

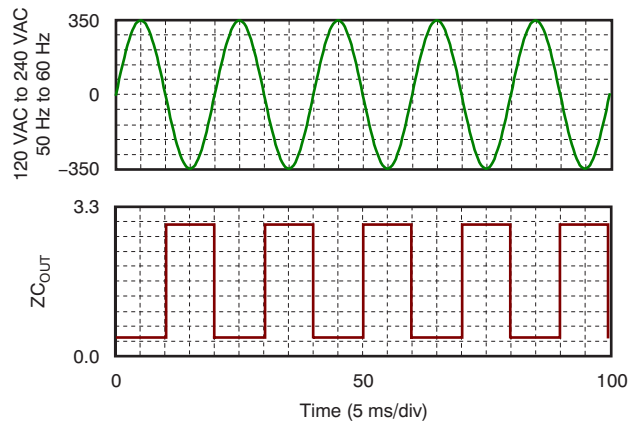

Figure 39. Non-Isolated Zero Crossing Waveforms

For maximum protection of the AFE030 against line transients, it is recommended to use Schottky diodes as indicated in [Figure 38](#). These diodes should limit the ZC_IN pins (pins 38 and 39) to within the maximum rating of $(AV_{DD} + 0.4\text{ V})$ and $(AGND - 0.4\text{ V})$. Some applications may require an isolated zero crossing detection circuit. With a minimal amount of components, the AFE030 can be configured for isolated zero crossing detection, as [Figure 40](#) shows.

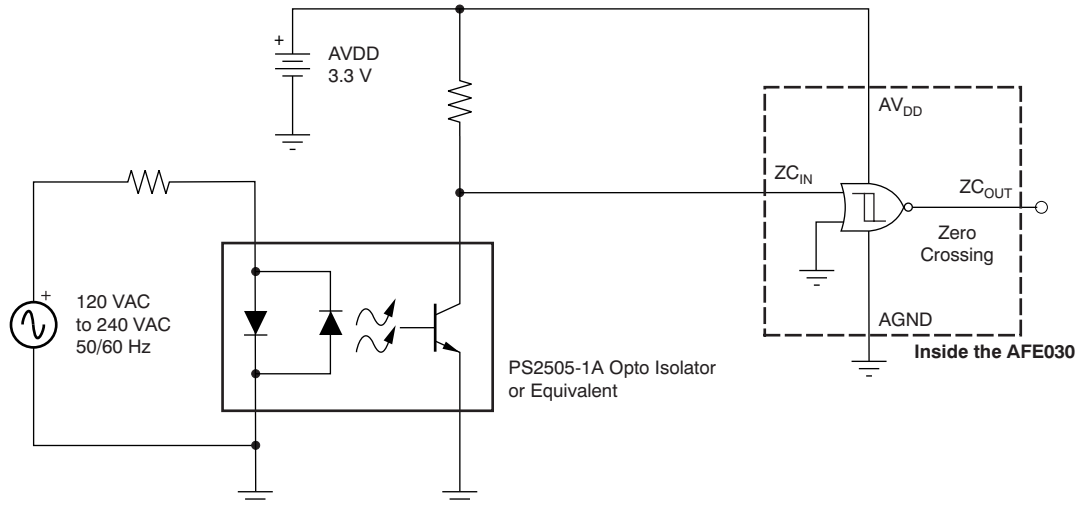

Figure 40. Isolated Zero Crossing Detection Using the AFE030

Isolated zero crossing waveforms are shown in [Figure 41](#).

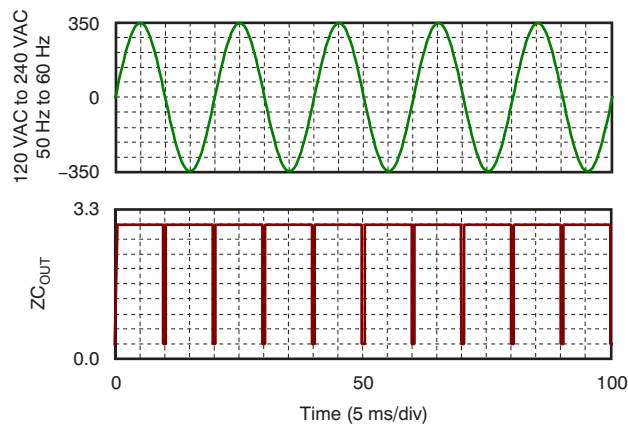

Figure 41. Isolated Zero Crossing Waveforms

ETx and ERx Blocks

The AFE030 contains a two-wire transmitter block, ETx, and a two-wire receiver block, ERx. These blocks support communications that use amplitude shift keying (ASK) with on-off keying (OOK) modulation.

The ETx block is a gated driver that allows for transmission of a carrier input signal and modulating input signal. For typical applications, a 50-kHz square wave carrier signal is applied to E_Tx_Clk while the modulating signal is applied to E_Tx_In. The output (E_Tx_Out) is then in a high-impedance state when E_Tx_In is '1'. Figure 42 shows the relationship between E_Tx_Clk, E_Tx_In, and E_Tx_Out.

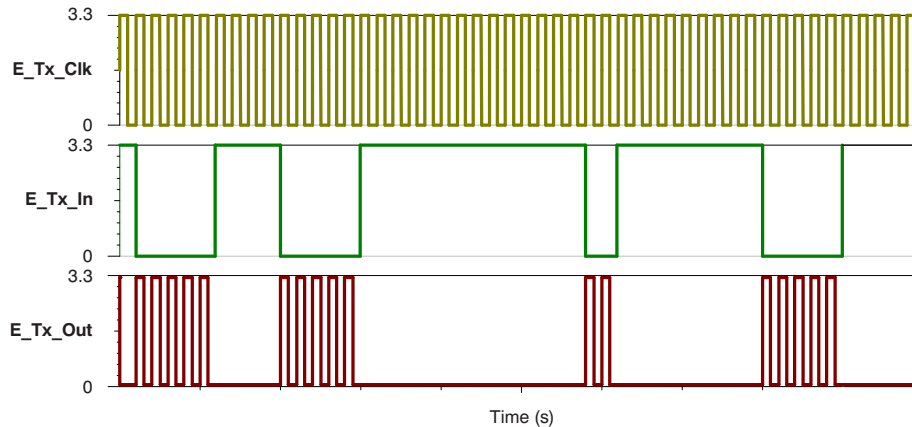

Figure 42. ETx Block Transfer Function

The ERx Block consists of a low-pass analog filter configured in an inverting gain of -4.5 db. This block, along with an external capacitor, can be used to create a passband filter response as shown in Figure 43.

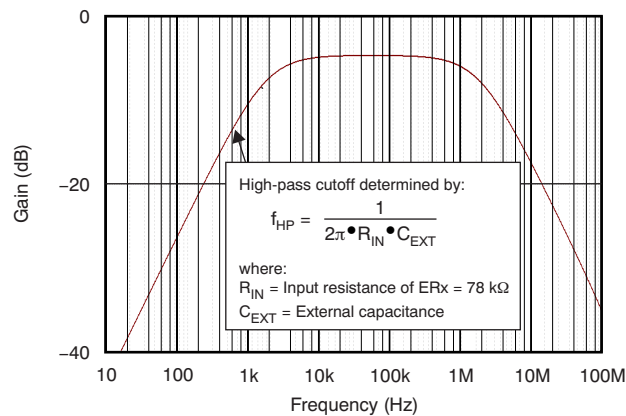

Figure 43. ERx Block Frequency Response

The E_Rx_Out pin can be directly connected to either an available analog-to-digital converter (ADC) input or GPIO on the host microcontroller. Figure 44 illustrates a typical two-wire application for ETx and ERx.

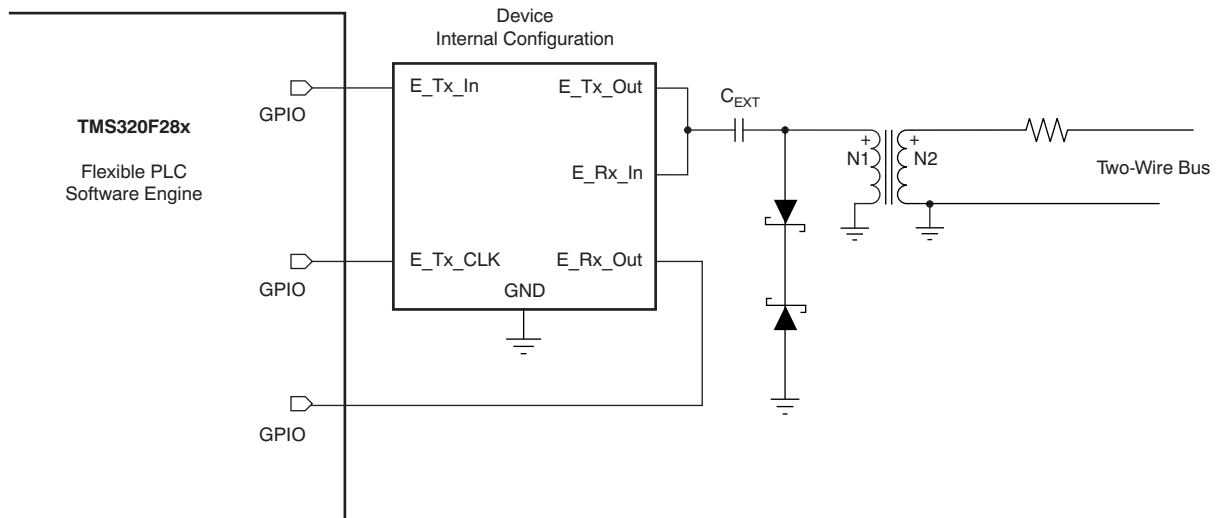

Figure 44. Typical Two-Wire Application for ETx and ERx

SERIAL INTERFACE

The AFE030 is controlled through a serial interface that allows read/write access to the control and data registers. A host SPI frame consists of a R/W bit, a 6-bit register address, and eight data bits. Data are shifted out on the falling edge of SCLK and latched on the rising edge of SCLK. Refer to the [Timing Diagrams](#) for a valid host SPI communications protocol. [Table 7](#) through [Table 16](#) show the complete register information.

Table 7. Data Register

REGISTER	ADDRESS	DEFAULT	FUNCTION
ENABLE1	01h	00h	Block enable or disable
GAIN SELECT	02h	32h	Rx and Tx gain select
ENABLE2	03h	00h	Block enable or disable
CONTROL1	04h	00h	Frequency select and calibration, Tx and Rx status
CONTROL2	05h	01h	Interrupt enable
RESET	09h	00h	Interrupt status and device reset
DIE_ID	0Ah	01h	Die name
REVISION	0Bh	02h	Die revision

Table 8. Command Register

BIT NAME	LOCATION (15 = MSB)	R/W	FUNCTION
ADDR8	8	W	Register address bit
ADDR9	9	W	Register address bit
ADDR10	10	W	Register address bit
ADDR11	11	W	Register address bit
ADDR12	12	W	Register address bit
ADDR13	13	W	Register address bit
ADDR14	14	W	Register address bit
R/W	15	W	Read/write: read = 1, write = 0

**Table 9. Enable1 Register: Address 00h
Default: 00h**

Enable1 Register <7:0>				
BIT NAME	LOCATION (0 = LSB)	DEFAULT	R/W	FUNCTION
PA	0	0	R/W	This bit is used to enable/disable the PA block. 0 = Disabled 1 = Enabled
TX	1	0	R/W	This bit is used to enable/disable the Tx block. 0 = Disabled 1 = Enabled
RX	2	0	R/W	This bit is used to enable/disable the Rx block. 0 = Disabled 1 = Enabled
ERX	3	0	R/W	This bit is used to enable/disable the ERx block. 0 = Disabled 1 = Enabled
ETX	4	0	R/W	This bit is used to enable/disable the ETx block. 0 = Disabled 1 = Enabled
DAC	5	0	R/W	This bit is used to enable/disable the DAC block. 0 = DAC disabled; switch is connected to Tx_PGA_IN pin. 1 = DAC enabled; switch is connected to DAC output.
—	6	0	—	Reserved
—	7	0	—	Reserved

**Table 10. Gain Select Register: Address 02h
Default: 32h**

Gain Select Register <7:0>				
BIT NAME	LOCATION (0 = LSB)	DEFAULT	R/W	FUNCTION
RX1G-0, RX1G-1	0, 1	0, 1	R/W	This bit is used to set the gain of the Rx PGA1. 00 = 0.25 V/V 01 = 0.5 V/V 10 = 1 V/V 11 = 2 V/V
RX2G-0, RX2G-1	2, 3	0, 0	R/W	This bit is used to set the gain of the Rx PGA2. 00 = 1 V/V 01 = 4 V/V 10 = 16 V/V 11 = 64 V/V
TXG-0, TXG-1	4, 5	1, 1	R/W	This bit is used to set the gain of the Tx PGA. 00 = 0.25 V/V 01 = 0.5 V/V 10 = 0.707 V/V 11 = 1 V/V
—	6	0	—	Reserved
—	7	0	—	Reserved

**Table 11. Enable2 Register: Address 03h
Default: 00h**

Enable2 Register <7:0>				
BIT NAME	LOCATION (0 = LSB)	DEFAULT	R/W	FUNCTION
ZC	0	0	R/W	This bit is used to enable/disable the ZC block. 0 = Disabled 1 = Enabled
REF1	1	0	R/W	This bit is used to enable/disable the REF1 block. 0 = Disabled 1 = Enabled
REF2	2	0	R/W	This bit is used to enable/disable the REF2 block. 0 = Disabled 1 = Enabled
PA_OUT	3	0	R/W	This bit is used to enable/disable the PA output stage. When the PA output stage is enabled it functions normally with a low output impedance, capable of driving heavy loads. When the PA output stage is disabled it is placed into a high impedance state. 0 = Disabled 1 = Enabled
—	4	0	—	Reserved
—	5	0	—	Reserved
—	6	0	—	Reserved
—	7	0	—	Reserved

**Table 12. Control1 Register: Address 04h
Default: 00h**

Control1 Register <7:0>				
BIT NAME	LOCATION (0 = LSB)	DEFAULT	R/W	FUNCTION
TX_CAL	0	0	R/W	This bit is used to enable/disable the TX calibration mode. 0 = Disabled 1 = Enabled
RX_CAL	1	0	R/W	This bit is used to enable/disable the RX calibration mode. 0 = Disabled 1 = Enabled
TX_PGA_CAL	2	0	R/W	This bit is used to enable/disable the TX PGA calibration mode. 0 = Disabled 1 = Enabled
CA_CBCD	3	0	R/W	This bit is used to select the frequency response of the Tx filter and Rx filter. 0 = CENELEC A 1 = CENELEC B, C, D
—	4	0	—	Reserved
—	5	0	—	Reserved
TX_FLAG	6	0	R	This bit is used to indicate the status of the Tx block. 0 = Tx block is not ready for transmission 1 = Tx block is ready for transmission
RX_FLAG	7	0	R	This bit is used to indicate the status of the Rx block. 0 = Rx block is not ready for reception 1 = Rx block is ready for reception

**Table 13. Control2 Register: Address 05h
Default: 01h**

Control2 Register <7:0>				
BIT NAME	LOCATION (0 = LSB)	DEFAULT	R/W	FUNCTION
—	0	0	—	Reserved
—	1	0	—	Reserved
—	2	0	—	Reserved
—	3	0	—	Reserved
—	4	0	—	Reserved
T_FLAG_EN	5	0	R/W	This bit is used to enable/disable the T_flag bit in the RESET Register. 0 = Disabled 1 = Enabled
I_FLAG_EN	6	0	R/W	This bit is used to enable/disable the I_flag bit in the RESET Register. 0 = Disabled 1 = Enabled
—	7	X	—	Reserved

**Table 14. RESET Register: Address 09h
Default: 00h**

Reset Register <7:0>				
BIT NAME	LOCATION (0 = LSB)	DEFAULT	R/W	FUNCTION
--	0	0	--	Reserved
--	1	0	--	Reserved
SOFTRST0, SOFTRST1, SOFTRST2	2, 3, 4	0, 0, 0	W	These bits are used to perform a software reset of the ENABLE1, ENABLE2, CONTROL2, CONTROL3, and GAIN SELECT registers. Writing '101' to these registers performs a software reset.
T_FLAG	5	0	R/W	This bit is used to indicate the status of a PA thermal overload. 0 = On read, indicates that no thermal overload has occurred since the last reset. 0 = On write, resets this bit. 1 = On read, indicates that a thermal overload has occurred since the last reset. Remains latched until reset.
I_FLAG	6	0	R/W	This bit is used to indicate the status of a PA output current overload. 0 = On read indicates that no current overload has occurred since the last reset. 0 = On write, resets this bit. 1 = On read indicates that a current overload has occurred since the last reset. Remains latched until reset.
—	7	0	—	Reserved

**Table 15. DieID Register: Address 0Ah
Default: 01h**

DieID Register <7:0>				
BIT NAME	LOCATION (0 = LSB)	DEFAULT	R/W	FUNCTION
DIE ID<0>	0	1	R	The DieID Register is hard-wired.
DIE ID<1>	1	0	R	The DieID Register is hard-wired.
DIE ID<2>	2	0	R	The DieID Register is hard-wired.
DIE ID<3>	3	0	R	The DieID Register is hard-wired.
DIE ID<4>	4	0	R	The DieID Register is hard-wired.
DIE ID<5>	5	0	R	The DieID Register is hard-wired.
DIE ID<6>	6	0	R	The DieID Register is hard-wired.
DIE ID<7>	7	0	R	The DieID Register is hard-wired.

**Table 16. Revision Register: Address 0Bh
Default: 02h**

Revision Register <7:0>				
BIT NAME	LOCATION (0 = LSB)	DEFAULT	R/W	FUNCTION
REVISION ID<0>	0	0	R	The Revision Register is hard-wired.
REVISION ID<1>	1	1	R	The Revision Register is hard-wired.
REVISION ID<2>	2	0	R	The Revision Register is hard-wired.
REVISION ID<3>	3	0	R	The Revision Register is hard-wired.
REVISION ID<4>	4	0	R	The Revision Register is hard-wired.
REVISION ID<5>	5	0	R	The Revision Register is hard-wired.
REVISION ID<6>	6	0	R	The Revision Register is hard-wired.
REVISION ID<7>	7	0	R	The Revision Register is hard-wired.

POWER SUPPLIES

The AFE030 has two low-voltage analog power-supply pins and one low-voltage digital supply pin. Internally, the two analog supply pins are connected to each other through back-to-back electrostatic discharge (ESD) protection diodes. These pins must be connected to each other on the application printed circuit board (PCB). It is also recommended to connect the digital supply pin and the two analog supply pins together on the PCB. Both low-voltage analog ground pins are also connected internally through back-to-back ESD protection diodes. These ground pins should also be connected to the digital ground pin on the PCB. It is recommended to bypass the low-voltage power supplies with a parallel combination of a 10- μ F and 100-nF capacitor. The PA block is biased separately from a high-voltage, high-current supply.

Two PA power supply pins and two PA ground pins are available to provide a path for the high currents associated with driving the low impedance of the ac mains. Connecting the two PA supply pins together as close as possible to the AFE030 is recommended. It is also recommended to place a bypass capacitor of 47 μ F to 100 μ F in parallel with 100 nF as close as possible to the AFE030. Care must be taken when routing the high current ground lines on the PCB to avoid creating voltage drops in the PCB ground that may vary with changes in load current.

The AFE030 has many options to enable or disable the functional blocks to allow for flexible power-savings modes. [Table 17](#) shows the specific power supply that each functional block draws power from, as well as the typical amount of power drawn from the associated power supplies for both the enabled and disabled states. For additional information on power-supply requirements refer to Application Report [SBOA130, Analog Front-End Design for a Narrowband Power-Line Communications Modem Using the AFE031](#) (available for download at [www.ti.com](#)).

Table 17. Power Consumption with Enable and Disable Times (Typical)

BLOCK	STATUS	ENABLE TIME	DISABLE TIME	AVDD SUPPLY CURRENT	DVDD SUPPLY CURRENT	PA SUPPLY CURRENT
PA	On	10 μ s	—	—	—	40 mA
	Off	—	10 μ s	—	—	70 μ A
Tx	On	10 μ s	—	3.7 mA	—	—
	Off	—	10 μ s	1 μ A	—	—
Rx	On	10 μ s	—	5.3 mA	—	—
	Off	—	10 μ s	1 μ A	—	—
ERx	On	10 μ s	—	900 μ A	—	—
	Off	—	10 μ s	1 μ A	—	—
ETx	On	10 μ s	—	1.2 mA	—	—
	Off	—	10 μ s	1 μ A	—	—
DAC	On	10 μ s	—	—	16 μ A	—
	Off	—	10 μ s	—	1 μ A	—
ZC	On	10 μ s	—	25 μ A	—	—
	Off	—	10 μ s	1 μ A	—	—
REF1	On	10 μ s	—	—	—	26 μ A
	Off	—	10 μ s	—	—	8 μ A
REF2	On	10 μ s	—	25 μ A	—	—
	Off	—	10 μ s	4 μ A	—	—

PIN DESCRIPTIONS

DAC (Pin 7)

The DAC pin is used to configure the SPI to either read or write data to the Command and Data Registers, or to write data to the DAC registers. Setting the DAC pin high allows access to the DAC registers. Setting the DAC pin low allows access to the Command and Data Registers.

SD (Pin 8)

The Shutdown pin (SD) can be used to shut down the entire AFE030 for maximum power savings. When the SD pin is low, normal operation of the AFE030 occurs. When the SD pin is high, all circuit blocks within the AFE030, including the serial interface, are placed into the lowest-power operating modes. In this condition, the entire AFE030 draws only 95 μ A of current. All register contents at the time the AFE030 is placed into shutdown mode are saved; upon re-enabling the AFE030, the register contents retain the respective saved values.

INT (Pin 9)

The Interrupt pin (INT) can be used to signal the microprocessor of an unusual operating condition that results from an anomaly on the ac mains. The INT pin can be triggered by two external circuit conditions, depending upon the Enable Register settings. The AFE030 can be programmed to issue an interrupt on these conditions:

- Current overload
- Thermal overload

Current Overload

The maximum output current allowed from the Power Amplifier can be programmed with the external R_{SET} resistor connected between PA_ISET (pin 46) and ground. If a fault condition should occur and cause an overcurrent event for the PA, the PA goes into current limit and the I_FLAG bit (location 6 in the [RESET Register](#)) is set to a '1' if the I_Flag_EN bit (location 6 in the [Control2 Register](#)) is enabled. This configuration results in an interrupt signal at the INT pin. The I_FLAG bit remains set to '1' even after the device returns to normal operation. The I_FLAG bit remains at '1' until it is reset by the microprocessor.

If the I_FLAG_EN bit (location 6 in the [Control2 Register](#)) is disabled and a current overload condition occurs, the PA goes into current-limit mode to protect the AFE030; however, the contents of the I_FLAG bit (location 6 in the [RESET Register](#)) remain at the respective previous values (presumably '0' for normal operation), and the AFE030 does not issue an interrupt at the INT pin.

Thermal Overload

The AFE030 contains internal protection circuitry that automatically disables the PA output stage if the junction temperature exceeds +165°C. If a fault condition occurs that causes a thermal overload, and if the T_FLAG_EN bit (location 5 in the [Control2 Register](#)) is enabled, the T_FLAG bit (location 5 in the [RESET Register](#)) is set to a '1'. This configuration results in an interrupt signal at the INT pin. The AFE030 includes a thermal hysteresis and allows the PA to resume normal operation when the junction temperature reduces to +145°C. The T_FLAG bit remains set to a '1' even after the device returns to normal operation. The T_FLAG bit remains '1' until it is reset by the microprocessor.

If the T_FLAG_EN bit (location 5 in the [Control2 Register](#)) is disabled and a thermal overload condition occurs, the PA continues to go into thermal limit and protect the AFE030, but the contents of the T_FLAG bit (location 5 in the [RESET Register](#)) remain at the previous value (presumably '0' for normal operation), and the AFE030 does not issue an interrupt at the INT pin.

Once an interrupt is signaled (that is, INT goes low), the contents of the I_FLAG and T_FLAG bits can be read by the microprocessor to determine the type of interrupt that occurred. Using the [Control2 Register](#), each interrupt type (current or thermal) can be individually enabled or disabled, allowing full user customization of the INT function. For proper operation of the interrupt pin it is recommended to configure the interrupt enable registers in the [Control2 Register](#) by writing to bit locations 5, 6, and 7 following the information in [Table 18](#) after each time the AFE030 is powered on. Failure to properly configure bit locations 5, 6, and 7 after power on may result in unexpected interrupt signals.

Table 18 lists the register contents associated with each interrupt condition.

Table 18. Register Contents to Configure the Interrupt Pin

FUNCTION	CONTROL2 REGISTER CONTENTS: DETERMINE INTERRUPT PIN FUNCTIONALITY		
	D7	I_FLAG_EN (CURRENT OVERLOAD)	T_FLAG_EN (THERMAL OVERLOAD)
		D6	D5
POR (default values)	undefined	0	0
No interrupt	0	0	0
Interrupt on thermal overload only	0	0	1
Interrupt on current overload only	0	1	0
Interrupt on thermal or current overload	0	1	1

TSENSE Pin (10)

The TSENSE pin is internally connected to the anode of a temperature-sensing diode located within the PA output stage. Figure 45 shows a remote junction temperature sensor circuit that can be used to measure the junction temperature of AFE030. Measuring the junction temperature of the AFE030 is optional and not required.

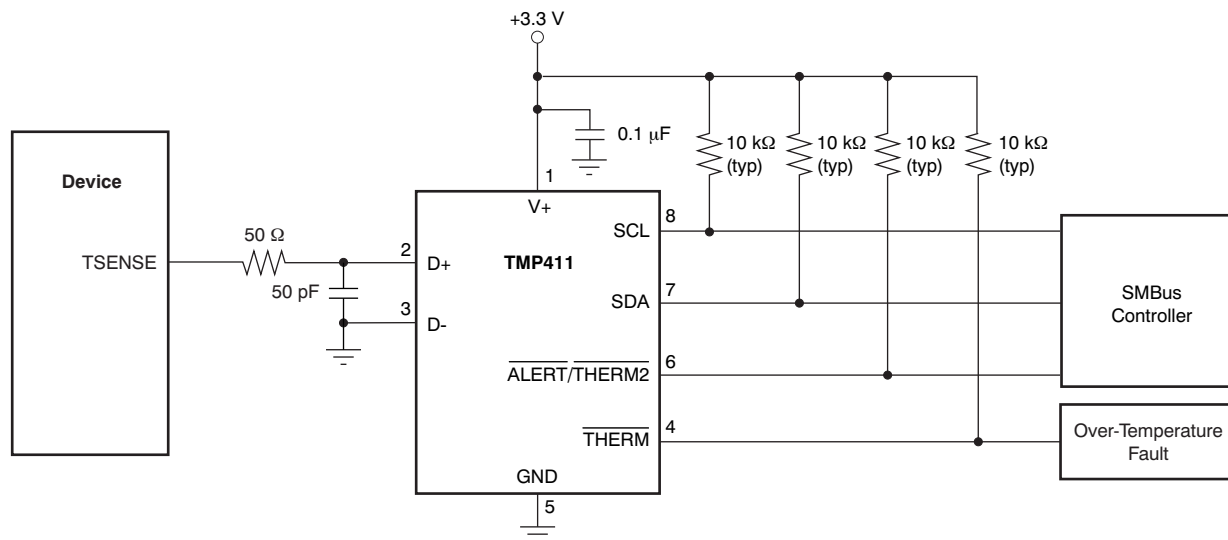

Figure 45. Interfacing the TMP411 to the AFE030

Tx_FLAG (Pin 47)

The Tx_FLAG pin is an open drain output that indicates the readiness of the Tx signal path for transmission. When the Tx_FLAG pin is high, the transmit signal path is enabled and ready for transmission. When the Tx_FLAG pin is low, the transmit path is not ready for transmission.

Rx_FLAG (Pin 48)

The Rx_FLAG pin is an open drain output that indicates the readiness of the Rx signal path for transmission. When the Rx_FLAG pin is high, the transmit signal path is enabled and ready for transmission. When the Rx_FLAG pin is low, the transmit path is not ready for transmission.

CALIBRATION MODES

The AFE030 can be configured for three different calibration modes: Tx Calibration, Rx Calibration, and Tx PGA Calibration. Calibration values can be determined during the calibration process and stored in system memory. A one-time calibration can be performed the first time that the system powers on; this calibration remains valid over the full temperature range and operating life of the AFE030, independent of the number of power-on/power-off cycles, as long as the calibration factors remain in the system memory. Calibration mode is accessed through the [Control1 Register](#). Note that calibration is not required.

Tx Calibration Mode

The Tx PGA + Tx Filter ac gain can be calibrated in Tx Calibration Mode. [Figure 46](#) shows the signal path during Tx Calibration mode.

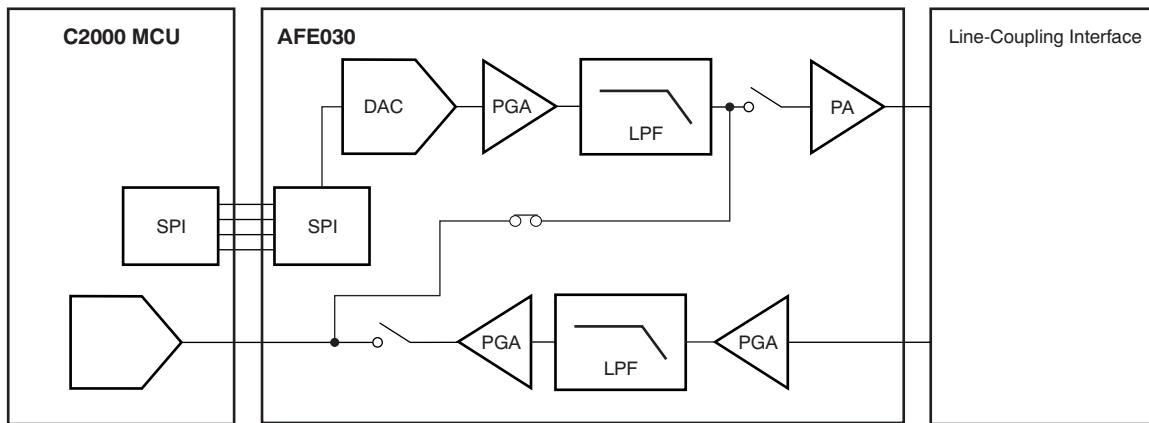

Figure 46. Tx Calibration Mode Configuration

Rx Calibration Mode

The Tx PGA + Rx PGA1 + Rx Filter + Rx PGA2 ac gain can be calibrated in Rx Calibration mode. [Figure 47](#) shows the signal path during Rx Calibration mode.

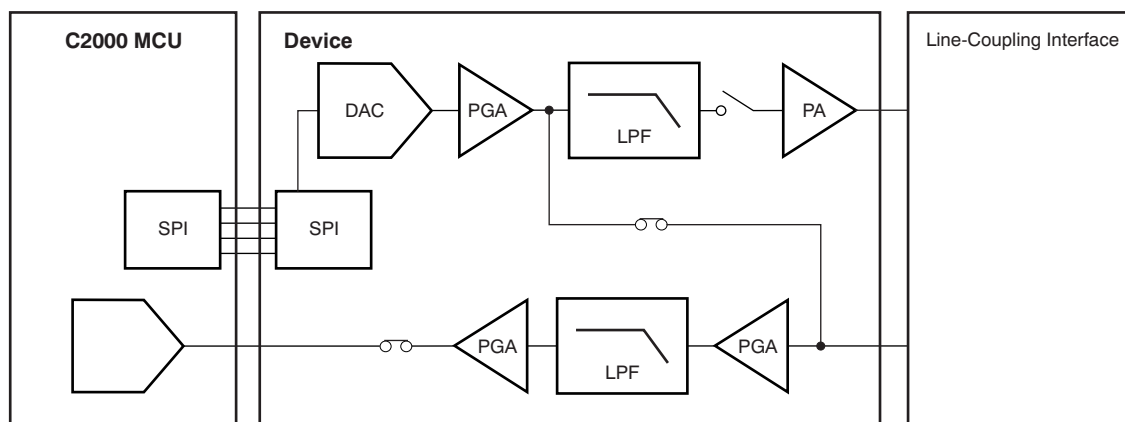

Figure 47. Rx Calibration Mode Configuration

Tx PGA Calibration Mode

The Tx PGA ac gain can be calibrated in Tx PGA Calibration mode. Figure 48 shows the signal path during Tx PGA Calibration mode.

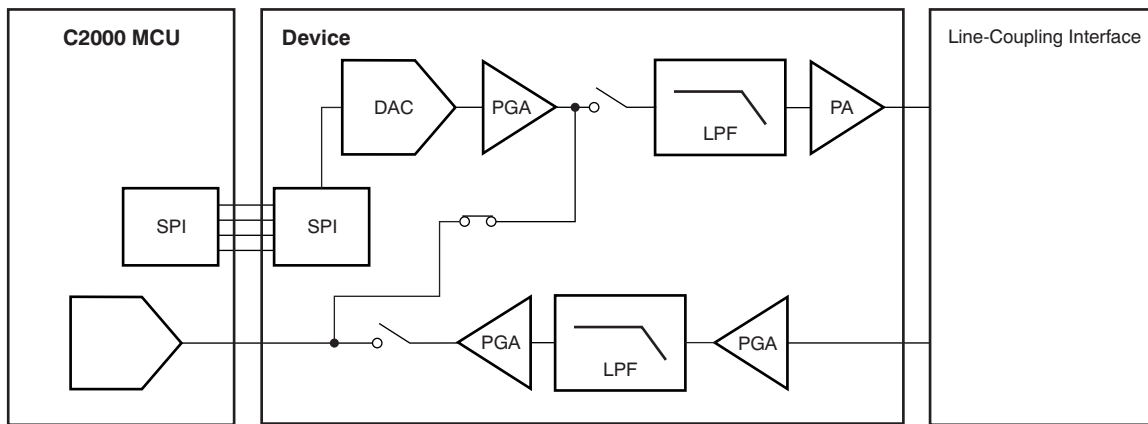
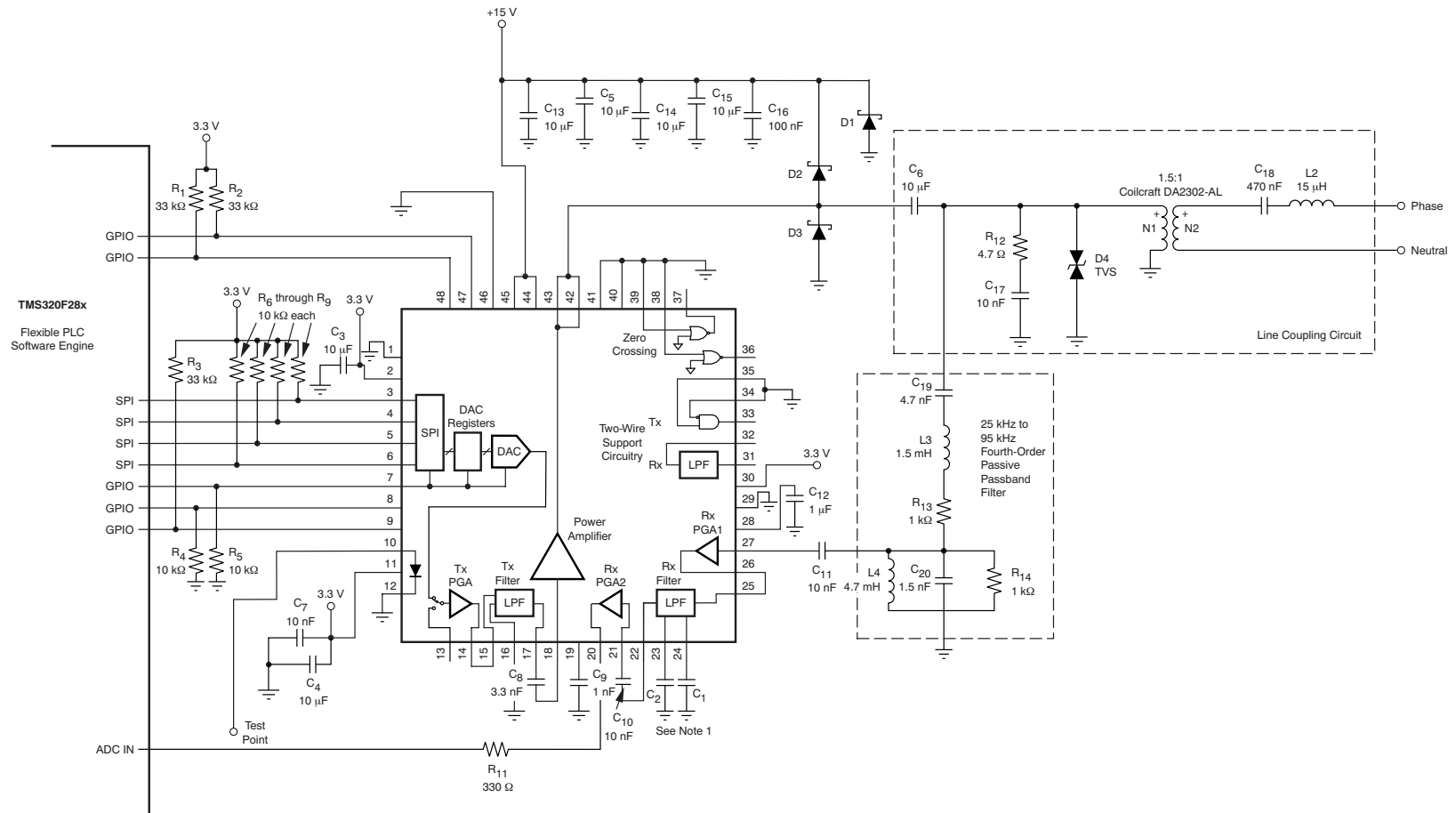

Figure 48. Tx PGA Calibration Mode Configuration

BASIC CONFIGURATION

Figure 49 shows the AFE030 configured in a typical PLC analog front-end application. The schematic shows the connections to the microprocessor and ac line. The values of the passive components in Figure 49 are suitable for a single-phase powerline communications application in the CENELEC A band, connected to a 120-VAC or 240-VAC, 50-Hz or 60-Hz ac line.



(1) Recommended values for C1 and C2:

1. C1:
 - CENELEC A: 680 pF
 - CENELEC B, C, D: 270 pF
2. C2:
 - CENELEC A: 680 pF
 - CENELEC B, C, D: 560 pF

Figure 49. Typical Powerline Communications Modem Application

LINE-COUPLING CIRCUIT

The line-coupling circuit is one of the most critical circuits in a powerline modem. The line-coupling circuit has two primary functions: first, to block the low-frequency signal of the mains (commonly 50 Hz or 60 Hz) from damaging the low-voltage modem circuitry; second, to couple the modem signal to and from the ac mains. A typical line-coupling circuit is shown in [Figure 50](#).

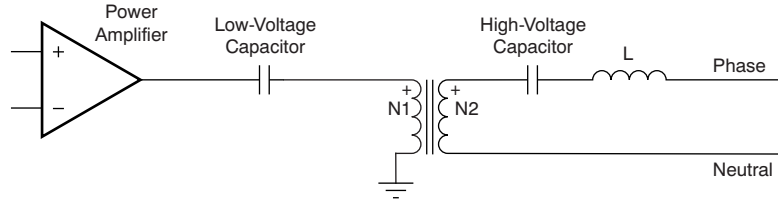

Figure 50. Simplified Line Coupling Circuit

For additional information on line-coupling interfaces with the AFE030, refer to Application Report [SBOA130](#), *Analog Front-End Design for a Narrowband Power-Line Communications Modem Using the AFE031* (available for download at [www.ti.com](#)).

CIRCUIT PROTECTION

Powerline communications are often located in operating environments that are harsh for electrical components connected to the ac line. Noise or surges from electrical anomalies such as lightning, capacitor bank switching, inductive switching, or other grid fault conditions can damage high-performance integrated circuits if they are not properly protected. The AFE030 can survive even the harshest conditions if several recommendations are followed.

First, dissipate as much of the electrical disturbance before it reaches the AFE030 with a multi-layer approach using metal-oxide varistors (MOVs), transient voltage suppression diodes (TVSs), Schottky diodes, and a Zener diode. [Figure 51](#) shows the recommended strategy for transient overvoltage protection.

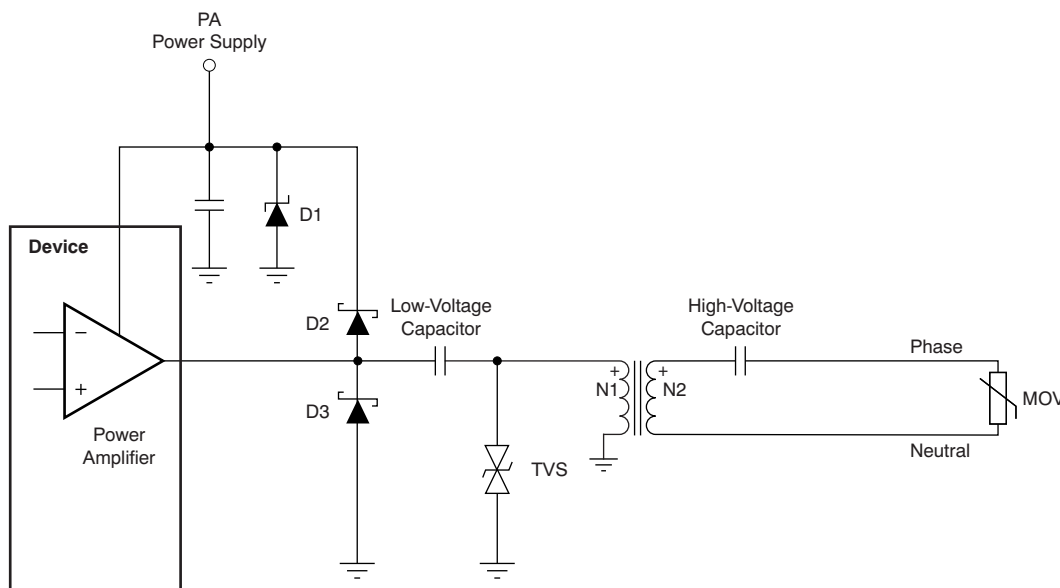

Figure 51. Transient Overvoltage Protection for AFE030

Note that the high-voltage coupling capacitor must be able to withstand pulses up to the clamping protection provided by the MOV. A metallized polypropylene capacitor, such as the 474MKP275KA from Illinois Capacitor, Inc., is rated for 50 Hz to 60 Hz, 250 VAC to 310 VAC, and can withstand 24 impulses of 2.5 kV.

Table 19 lists several recommended transient protection components.

Table 19. Recommended Transient Protection Devices

COMPONENT	120 VAC, 60 Hz		
	DESCRIPTION	MANUFACTURER	MFR PART NO (OR EQUIVALENT)
D1	Zener diode	Diodes, Inc.	1SMB59xxB ⁽¹⁾
D2, D3	Schottky diode	Diodes, Inc.	1N5819HW
TVS	Transient voltage suppressor	Diodec Semiconductor	P6SMBJxxC ⁽²⁾
MOV	Varistor	LittleFuse	TMOV20RP140E
HV Cap	High-voltage capacitor	Illinois Capacitor, Inc	474MKP275KA ⁽³⁾
COMPONENT	240 VAC, 50 Hz		
	DESCRIPTION	MANUFACTURER	MFR PART NO (OR EQUIVALENT)
D1	Zener diode	Diodes, Inc.	1SMB59xxB ⁽¹⁾
D2, D3	Schottky diode	Diodes, Inc.	1N5819HW
TVS	Transient voltage suppressor	Diodec Semiconductor	P6SMBJxxC ⁽²⁾
MOV	Varistor	LittleFuse	TMOV20RP300E
HV Cap	High-voltage capacitor	Illinois Capacitor, Inc	474MKP275KA ⁽³⁾

- (1) Select the Zener breakdown voltage at the lowest available rating beyond the normal power-supply operating range.
- (2) Select the TVS breakdown voltage at or slightly greater than $(0.5 \times PA_{VS})$.
- (3) A common value for the high-voltage capacitor is 470 nF. Other values may be substituted depending on the requirements of the application. Note that when making a substitution, it is important in terms of reliability that the capacitor be selected from the same family or equivalent family of capacitors rated to withstand high-voltage surges.

THERMAL CONSIDERATIONS

In a typical powerline communications application, the AFE030 dissipates 1 W of power when transmitting into the low impedance of the ac line. This amount of power dissipation can increase the junction temperature, which in turn can lead to a thermal overload that results in signal transmission interruptions if the proper thermal design of the PCB has not been performed. Proper management of heat flow from the AFE030 as well as good PCB design and construction are required to ensure proper device temperature, maximize performance, and extend device operating life.

The AFE030 is assembled into a 7-mm² x 7-mm², 48-lead, QFN package. As Figure 52 shows, this QFN package has a large area exposed thermal pad on the underside that is used to conduct heat away from the AFE030 and into the underlying PCB.

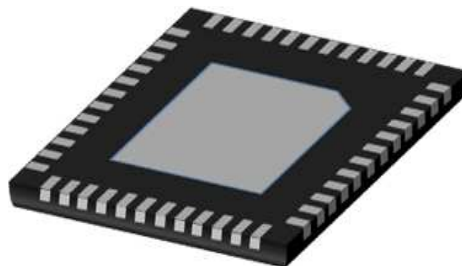

Figure 52. QFN Package with Large Area Exposed Thermal Pad

Some heat is conducted from the silicon die surface through the plastic packaging material and is transferred into the ambient environment. Because plastic is a relatively poor conductor of heat, however, this route is not the primary thermal path for heat flow. Heat also flows across the silicon die surface to the bond pads, through the wire bonds, into the package leads, and finally into the top layer of the PCB. While both of these paths for heat flow are important, the majority (nearly 80%) of the heat flows downward, through the silicon die, into the thermally-conductive die attach epoxy, and into the exposed thermal pad on the underside of the package (as shown in Figure 53). Minimizing the thermal resistance of this downward path to the ambient environment maximizes the life and performance of the device.

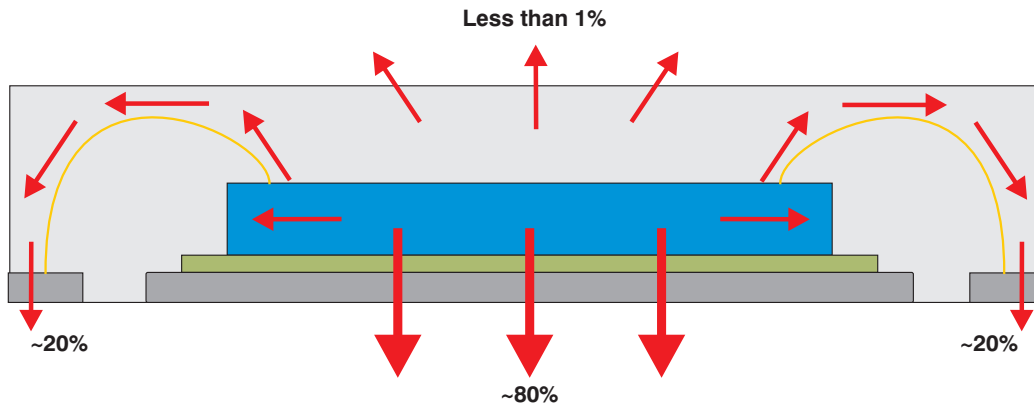

Figure 53. Heat Flow in the QFN Package

The exposed thermal pad must be soldered to the PCB thermal pad. The thermal pad on the PCB should be the same size as the exposed thermal pad on the underside of the QFN package. Refer to Application Report, *QFN/SON PCB Attachment*, literature number [SLUA271A](#), for recommendations on attaching the thermal pad to the PCB. Figure 54 illustrates the direction of heat spreading into the PCB from the device.

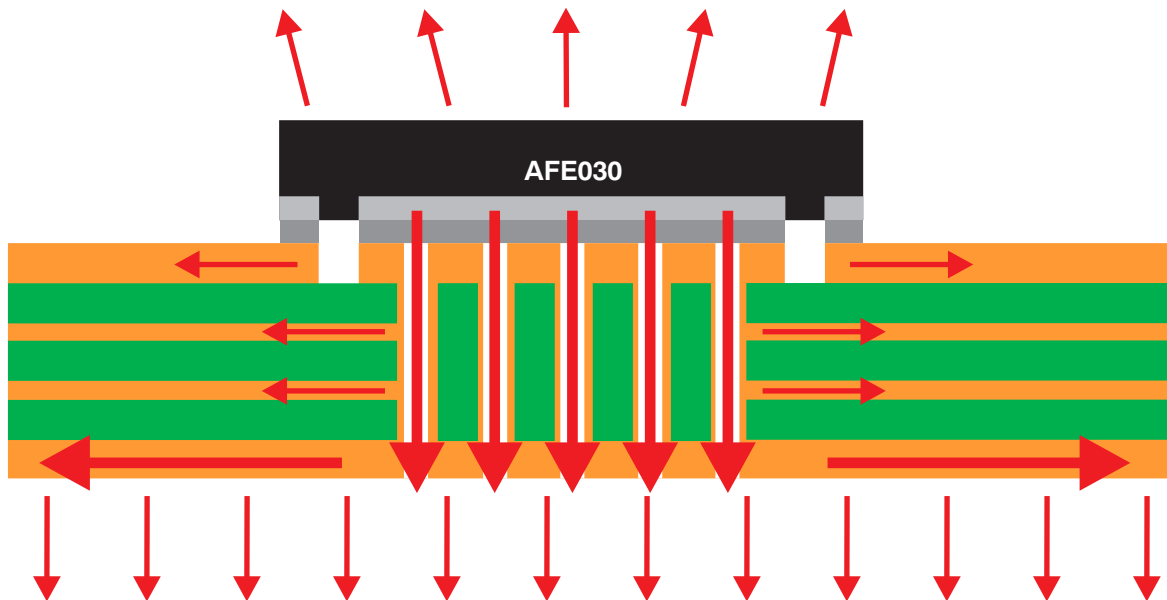

Figure 54. Heat Spreading into PCB

The heat spreading into the PCB is maximized if the thermal path is uninterrupted. Best results are achieved if the heat-spreading surfaces are filled with copper to the greatest extent possible, maximizing the percent area covered on each layer. As an example, a thermally robust, multilayer PCB design may consist of four layers with copper (Cu) coverage of 60% in the top layer, 85% and 90% in the inner layers, respectively, and 95% on the bottom layer.

Increasing the number of layers in the PCB, using thicker copper, and increasing the PCB area are all factors that improve the spread of heat. Figure 55 through Figure 57, respectively, show thermal resistance performance as a function of each of these factors.

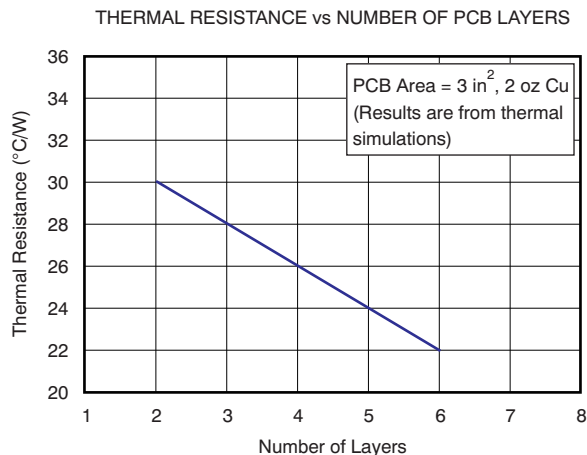

Figure 55. Thermal Resistance as a Function of the Number of Layers in the PCB

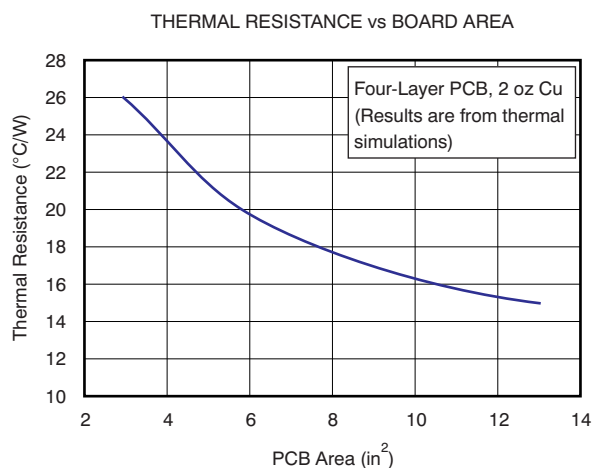

Figure 56. Thermal Resistance as a Function of PCB Area

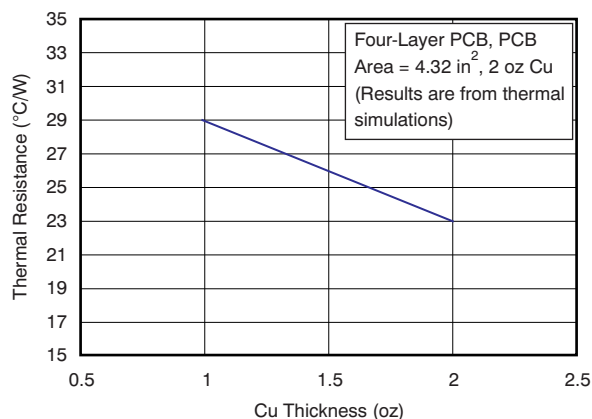

Figure 57. Thermal Resistance as a Function of Copper Thickness

For additional information on thermal PCB design using exposed thermal pad packages, refer to Application Report [SBOA130](#), *Analog Front-End Design for a Narrowband Power-Line Communications Modem Using the AFE031* and Application Report [SLMA002E](#), *PowerPAD™ Thermally-Enhanced Package* (both available for download at www.ti.com).

Powerline Communications Developer's Kit

A PLC developer's kit ([TMDSPCKIT-V3](#)) is available to order at www.ti.com/plc. This kit offers complete hardware and software solutions for introducing flexible, efficient, and reliable networking capabilities to a wide variety of applications. With unique modular hardware architecture and flexible software framework, TI's PLC solutions are the only PLC-based technology capable of supporting multiple protocol standards and modulation schemes with a single platform. This technology enables designers to leverage product lines across global markets. The flexibility of the platform also allows developers to optimize hardware and software performance for specific environmental operating conditions while simplifying end-to-end product design. Based on TI's powerful C2000™ microcontroller architecture and the AFE031, developers can select the correct blend of processing capacity and peripherals to either add powerline communications to an existing design or implement a complete application with PLC communications.

The C2000 Powerline Modem Developer's Kit enables easy development of software-based PLC modems. The kit includes two PLC modems based on the C2000 TMS320F28069 controlCARD and the AFE031. The included PLC SUITE software supports several communication techniques, including OFDM (PRIME/G3 and FlexOFDM) and SFSK. The kit also includes onboard USB JTAG emulation and Code Composer Studio.

PACKAGING/MECHANICALS

Complete mechanical drawings and packaging information are appended to the end of this data sheet.

REVISION HISTORY

NOTE: Page numbers for previous revisions may differ from page numbers in the current version.

Changes from Original (December 2011) to Revision A	Page
• Changed product status to Production Data	1
• Added cross-reference to footnote 2 to <i>Output short-circuit (PA)</i> parameter in Absolute Maximum Ratings table	2

PACKAGING INFORMATION

Orderable Device	Status ⁽¹⁾	Package Type	Package Drawing	Pins	Package Qty	Eco Plan ⁽²⁾	Lead/ Ball Finish	MSL Peak Temp ⁽³⁾	Samples (Requires Login)
AFE030AIRGZR	ACTIVE	VQFN	RGZ	48	2500	Green (RoHS & no Sb/Br)	CU NIPDAU	Level-2-260C-1 YEAR	
AFE030AIRGZT	ACTIVE	VQFN	RGZ	48	250	Green (RoHS & no Sb/Br)	CU NIPDAU	Level-2-260C-1 YEAR	

⁽¹⁾ The marketing status values are defined as follows:

ACTIVE: Product device recommended for new designs.

LIFEBUY: TI has announced that the device will be discontinued, and a lifetime-buy period is in effect.

NRND: Not recommended for new designs. Device is in production to support existing customers, but TI does not recommend using this part in a new design.

PREVIEW: Device has been announced but is not in production. Samples may or may not be available.

OBsolete: TI has discontinued the production of the device.

⁽²⁾ Eco Plan - The planned eco-friendly classification: Pb-Free (RoHS), Pb-Free (RoHS Exempt), or Green (RoHS & no Sb/Br) - please check <http://www.ti.com/productcontent> for the latest availability information and additional product content details.

TBD: The Pb-Free/Green conversion plan has not been defined.

Pb-Free (RoHS): TI's terms "Lead-Free" or "Pb-Free" mean semiconductor products that are compatible with the current RoHS requirements for all 6 substances, including the requirement that lead not exceed 0.1% by weight in homogeneous materials. Where designed to be soldered at high temperatures, TI Pb-Free products are suitable for use in specified lead-free processes.

Pb-Free (RoHS Exempt): This component has a RoHS exemption for either 1) lead-based flip-chip solder bumps used between the die and package, or 2) lead-based die adhesive used between the die and leadframe. The component is otherwise considered Pb-Free (RoHS compatible) as defined above.

Green (RoHS & no Sb/Br): TI defines "Green" to mean Pb-Free (RoHS compatible), and free of Bromine (Br) and Antimony (Sb) based flame retardants (Br or Sb do not exceed 0.1% by weight in homogeneous material)

⁽³⁾ MSL, Peak Temp. -- The Moisture Sensitivity Level rating according to the JEDEC industry standard classifications, and peak solder temperature.

Important Information and Disclaimer: The information provided on this page represents TI's knowledge and belief as of the date that it is provided. TI bases its knowledge and belief on information provided by third parties, and makes no representation or warranty as to the accuracy of such information. Efforts are underway to better integrate information from third parties. TI has taken and continues to take reasonable steps to provide representative and accurate information but may not have conducted destructive testing or chemical analysis on incoming materials and chemicals. TI and TI suppliers consider certain information to be proprietary, and thus CAS numbers and other limited information may not be available for release.

In no event shall TI's liability arising out of such information exceed the total purchase price of the TI part(s) at issue in this document sold by TI to Customer on an annual basis.

TAPE AND REEL INFORMATION

REEL DIMENSIONS

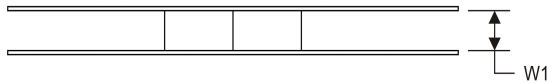
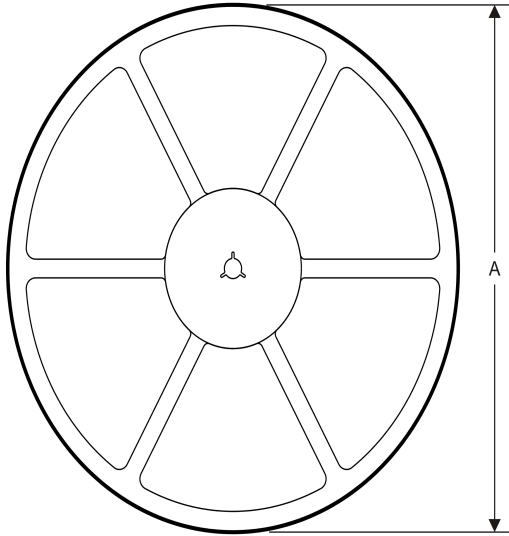

TAPE DIMENSIONS

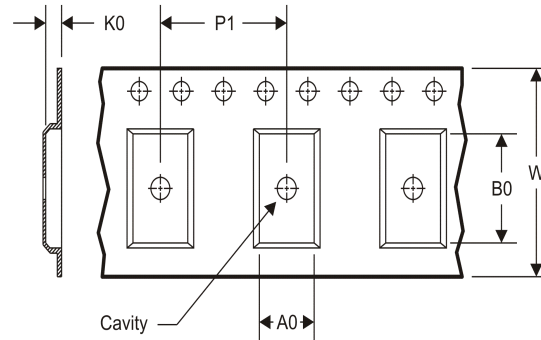

A0	Dimension designed to accommodate the component width
B0	Dimension designed to accommodate the component length
K0	Dimension designed to accommodate the component thickness
W	Overall width of the carrier tape
P1	Pitch between successive cavity centers

TAPE AND REEL INFORMATION

*All dimensions are nominal

Device	Package Type	Package Drawing	Pins	SPQ	Reel Diameter (mm)	Reel Width W1 (mm)	A0 (mm)	B0 (mm)	K0 (mm)	P1 (mm)	W (mm)	Pin1 Quadrant
AFE030AIRGZR	VQFN	RGZ	48	2500	330.0	16.4	7.3	7.3	1.5	12.0	16.0	Q2
AFE030AIRGZT	VQFN	RGZ	48	250	180.0	16.4	7.3	7.3	1.5	12.0	16.0	Q2

TAPE AND REEL BOX DIMENSIONS

*All dimensions are nominal

Device	Package Type	Package Drawing	Pins	SPQ	Length (mm)	Width (mm)	Height (mm)
AFE030AIRGZR	VQFN	RGZ	48	2500	346.0	346.0	33.0
AFE030AIRGZT	VQFN	RGZ	48	250	210.0	185.0	35.0

RGZ (S-PVQFN-N48)

PLASTIC QUAD FLATPACK NO-LEAD

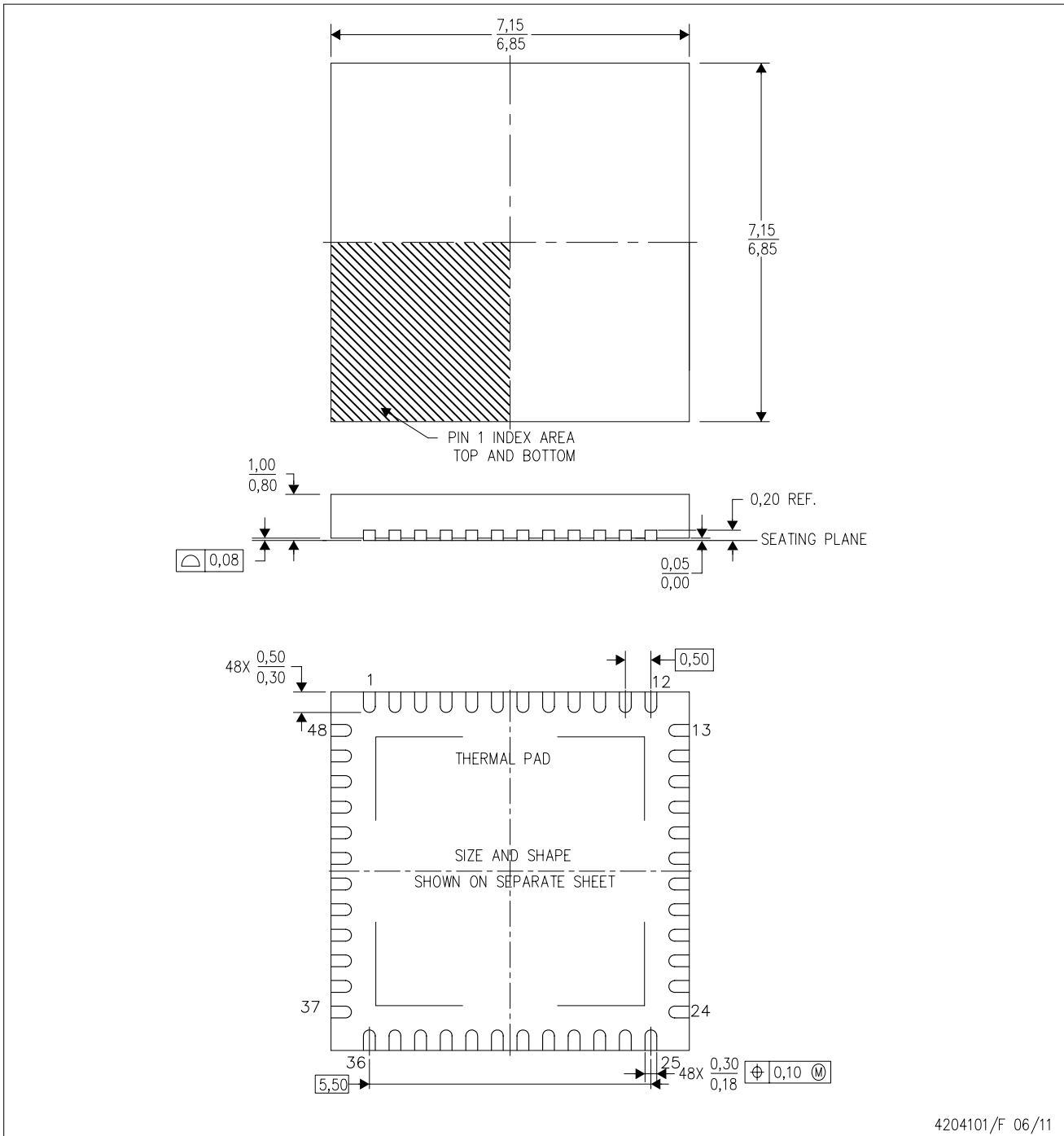

- NOTES:
- A. All linear dimensions are in millimeters. Dimensioning and tolerancing per ASME Y14.5M-1994.
 - B. This drawing is subject to change without notice.
 - C. Quad Flatpack, No-leads (QFN) package configuration.
 - D. The package thermal pad must be soldered to the board for thermal and mechanical performance.
 - E. See the additional figure in the Product Data Sheet for details regarding the exposed thermal pad features and dimensions.
 - F. Falls within JEDEC MO-220.

THERMAL PAD MECHANICAL DATA

RGZ (S-PVQFN-N48)

PLASTIC QUAD FLATPACK NO-LEAD

THERMAL INFORMATION

This package incorporates an exposed thermal pad that is designed to be attached directly to an external heatsink. The thermal pad must be soldered directly to the printed circuit board (PCB). After soldering, the PCB can be used as a heatsink. In addition, through the use of thermal vias, the thermal pad can be attached directly to the appropriate copper plane shown in the electrical schematic for the device, or alternatively, can be attached to a special heatsink structure designed into the PCB. This design optimizes the heat transfer from the integrated circuit (IC).

For information on the Quad Flatpack No-Lead (QFN) package and its advantages, refer to Application Report, QFN/SON PCB Attachment, Texas Instruments Literature No. SLUA271. This document is available at www.ti.com.

The exposed thermal pad dimensions for this package are shown in the following illustration.

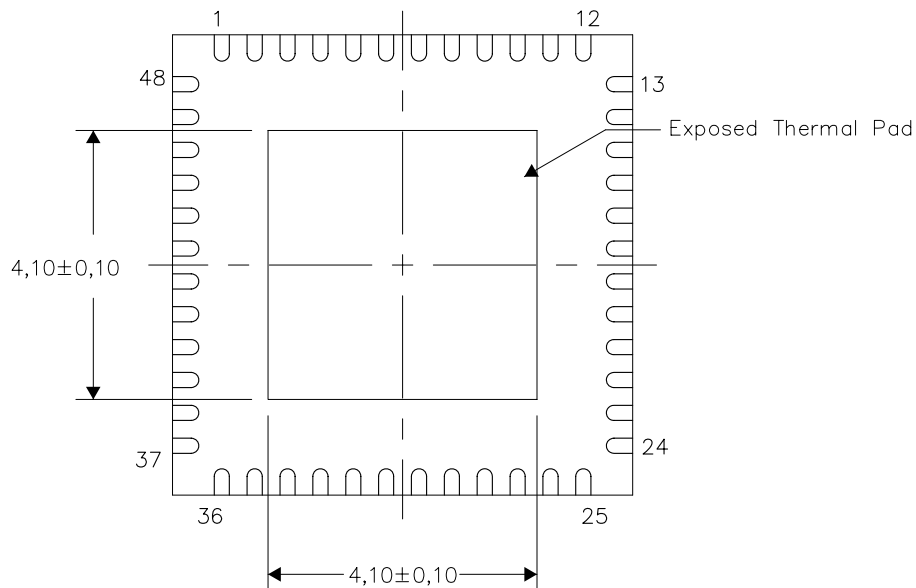

Bottom View

Exposed Thermal Pad Dimensions

4206354-3/R 08/11

NOTE: All linear dimensions are in millimeters

RGZ (S-PVQFN-N48)

PLASTIC QUAD FLATPACK NO-LEAD

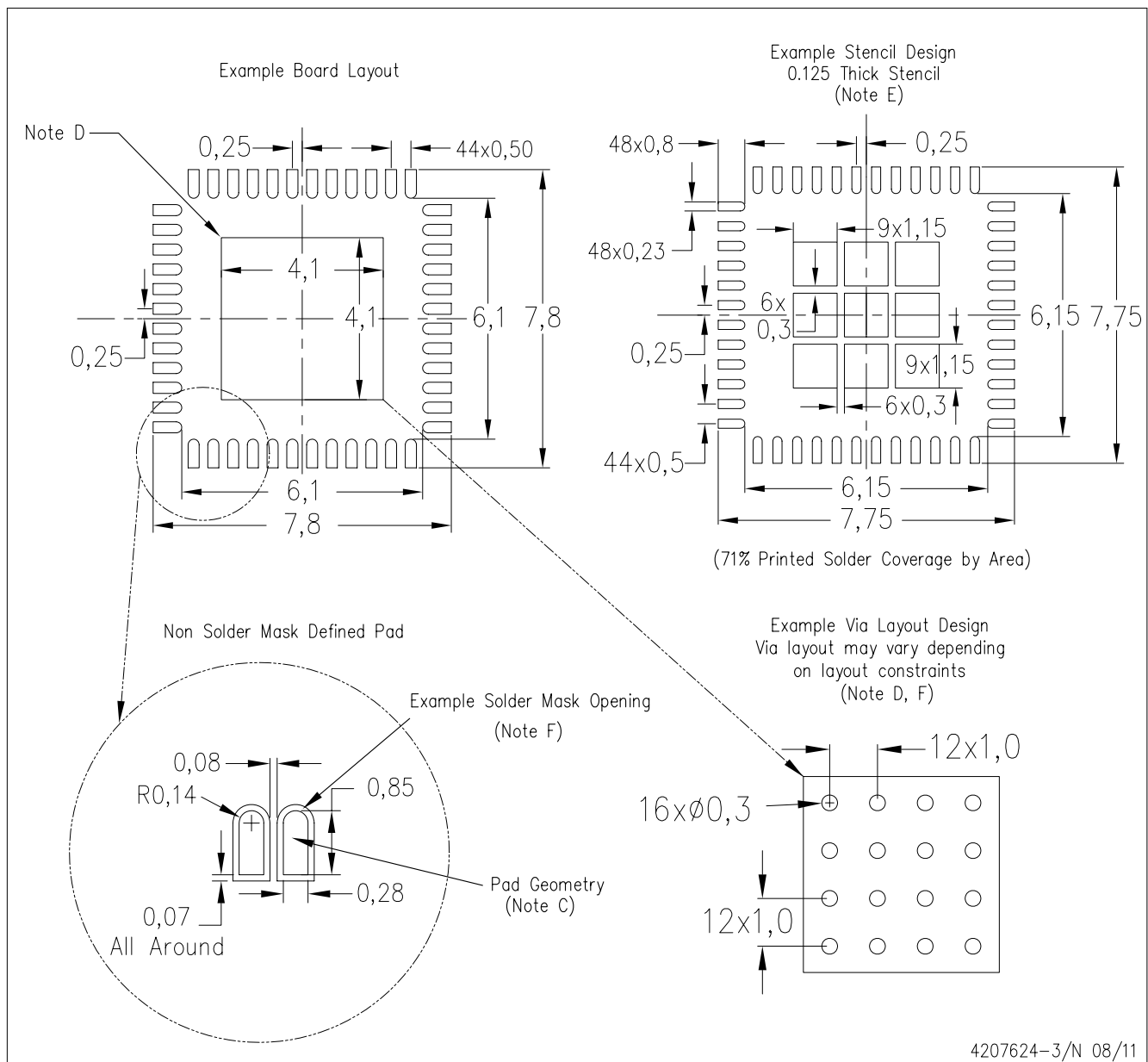

4207624-3/N 08/11

- NOTES:
- All linear dimensions are in millimeters.
 - This drawing is subject to change without notice.
 - Publication IPC-7351 is recommended for alternate designs.
 - This package is designed to be soldered to a thermal pad on the board. Refer to Application Note, Quad Flat-Pack Packages, Texas Instruments Literature No. SLUA271, and also the Product Data Sheets for specific thermal information, via requirements, and recommended board layout. These documents are available at www.ti.com <<http://www.ti.com>>.
 - Laser cutting apertures with trapezoidal walls and also rounding corners will offer better paste release. Customers should contact their board assembly site for stencil design recommendations. Refer to IPC 7525 for stencil design considerations.
 - Customers should contact their board fabrication site for recommended solder mask tolerances and via tenting recommendations for vias placed in the thermal pad.

IMPORTANT NOTICE

Texas Instruments Incorporated and its subsidiaries (TI) reserve the right to make corrections, modifications, enhancements, improvements, and other changes to its products and services at any time and to discontinue any product or service without notice. Customers should obtain the latest relevant information before placing orders and should verify that such information is current and complete. All products are sold subject to TI's terms and conditions of sale supplied at the time of order acknowledgment.

TI warrants performance of its hardware products to the specifications applicable at the time of sale in accordance with TI's standard warranty. Testing and other quality control techniques are used to the extent TI deems necessary to support this warranty. Except where mandated by government requirements, testing of all parameters of each product is not necessarily performed.

TI assumes no liability for applications assistance or customer product design. Customers are responsible for their products and applications using TI components. To minimize the risks associated with customer products and applications, customers should provide adequate design and operating safeguards.

TI does not warrant or represent that any license, either express or implied, is granted under any TI patent right, copyright, mask work right, or other TI intellectual property right relating to any combination, machine, or process in which TI products or services are used. Information published by TI regarding third-party products or services does not constitute a license from TI to use such products or services or a warranty or endorsement thereof. Use of such information may require a license from a third party under the patents or other intellectual property of the third party, or a license from TI under the patents or other intellectual property of TI.

Reproduction of TI information in TI data books or data sheets is permissible only if reproduction is without alteration and is accompanied by all associated warranties, conditions, limitations, and notices. Reproduction of this information with alteration is an unfair and deceptive business practice. TI is not responsible or liable for such altered documentation. Information of third parties may be subject to additional restrictions.

Resale of TI products or services with statements different from or beyond the parameters stated by TI for that product or service voids all express and any implied warranties for the associated TI product or service and is an unfair and deceptive business practice. TI is not responsible or liable for any such statements.

TI products are not authorized for use in safety-critical applications (such as life support) where a failure of the TI product would reasonably be expected to cause severe personal injury or death, unless officers of the parties have executed an agreement specifically governing such use. Buyers represent that they have all necessary expertise in the safety and regulatory ramifications of their applications, and acknowledge and agree that they are solely responsible for all legal, regulatory and safety-related requirements concerning their products and any use of TI products in such safety-critical applications, notwithstanding any applications-related information or support that may be provided by TI. Further, Buyers must fully indemnify TI and its representatives against any damages arising out of the use of TI products in such safety-critical applications.

TI products are neither designed nor intended for use in military/aerospace applications or environments unless the TI products are specifically designated by TI as military-grade or "enhanced plastic." Only products designated by TI as military-grade meet military specifications. Buyers acknowledge and agree that any such use of TI products which TI has not designated as military-grade is solely at the Buyer's risk, and that they are solely responsible for compliance with all legal and regulatory requirements in connection with such use.

TI products are neither designed nor intended for use in automotive applications or environments unless the specific TI products are designated by TI as compliant with ISO/TS 16949 requirements. Buyers acknowledge and agree that, if they use any non-designated products in automotive applications, TI will not be responsible for any failure to meet such requirements.

Following are URLs where you can obtain information on other Texas Instruments products and application solutions:

Products

Audio	www.ti.com/audio
Amplifiers	amplifier.ti.com
Data Converters	dataconverter.ti.com
DLP® Products	www.dlp.com
DSP	dsp.ti.com
Clocks and Timers	www.ti.com/clocks
Interface	interface.ti.com
Logic	logic.ti.com
Power Mgmt	power.ti.com
Microcontrollers	microcontroller.ti.com
RFID	www.ti-rfid.com
OMAP Mobile Processors	www.ti.com/omap
Wireless Connectivity	www.ti.com/wirelessconnectivity

Applications

Automotive and Transportation	www.ti.com/automotive
Communications and Telecom	www.ti.com/communications
Computers and Peripherals	www.ti.com/computers
Consumer Electronics	www.ti.com/consumer-apps
Energy and Lighting	www.ti.com/energy
Industrial	www.ti.com/industrial
Medical	www.ti.com/medical
Security	www.ti.com/security
Space, Avionics and Defense	www.ti.com/space-avionics-defense
Video and Imaging	www.ti.com/video

TI E2E Community Home Page

e2e.ti.com

Mailing Address: Texas Instruments, Post Office Box 655303, Dallas, Texas 75265
Copyright © 2012, Texas Instruments Incorporated