

## 2.2V, 12-Bit, 4-Channel, *microPOWER*<sup>™</sup> ANALOG-TO-DIGITAL CONVERTER WITH I<sup>2</sup>C INTERFACE

Check for Samples: [ADS7924](#)

### FEATURES

- **Intelligent Monitoring:**
  - Auto-Sequencing of 4-Channel Multiplexer
  - Individual Alarm Thresholds for Each Channel
  - Programmable Scan Rate
- **Micropower Monitoring:**
  - **Four-Channel Scanning:**
    - Every 1ms → 25μW
    - Every 10ms → 5μW
    - < 1μA of Power-Down Current
  - Programmable Interrupt Pin Controls Shutdown/Wakeup of the Microcontroller
  - Auto Power-Down Control
  - PWRCON Pin Allows Shutdown of External Op Amp
- **Wide Supply Range:**
  - Analog Supply: 2.2V to 5.5V
  - Digital Supply: 1.65V to 5.5V
- **Small Footprint: 3mm × 3mm QFN**

### APPLICATIONS

- **Portable and Battery-Powered Systems:**
  - Medical, Communications, Remote Sensor Signal Monitoring, Power-Supply Monitoring
- **Energy Harvesting**

### DESCRIPTION

The ADS7924 is a four-channel, 12-bit, analog-to-digital converter (ADC) with an I<sup>2</sup>C<sup>™</sup> interface. With its low-power ADC core, support for low-supply operation, and a flexible measurement sequencer that essentially eliminates power consumption between conversions, the ADS7924 forms a complete monitoring system for power-critical applications such as battery-powered equipment and energy harvesting systems.

The ADS7924 features dedicated data registers and onboard programmable digital threshold comparators for each input. Alarm conditions can be programmed that generate an interrupt. The combination of data buffering, programmable threshold comparisons, and alarm interrupts minimize the host microcontroller time needed to supervise the ADS7924.

The four-channel input multiplexer (MUX) is routed through external pins to allow a common signal conditioning circuit to be used between the MUX and ADC, thereby reducing overall component count. The low-power ADC uses the analog supply as its reference and can acquire and convert signals in only 10μs. An onboard oscillator eliminates the need to supply a master clock.

The ADS7924 is offered in a small 3mm × 3mm QFN and is fully specified for operation over the industrial temperature range of –40°C to +85°C.

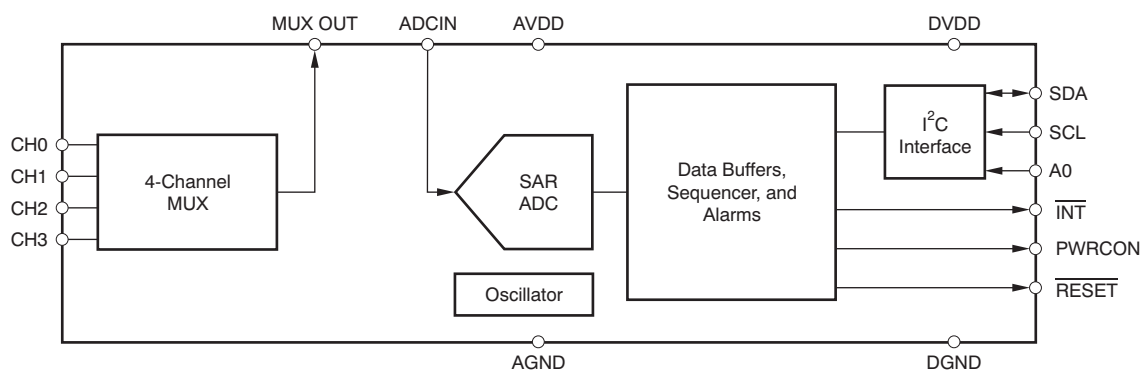

Please be aware that an important notice concerning availability, standard warranty, and use in critical applications of Texas Instruments semiconductor products and disclaimers thereto appears at the end of this data sheet.

*microPOWER* is a trademark of Texas Instruments Incorporated.

I<sup>2</sup>C is a trademark of NXP Semiconductors.

All other trademarks are the property of their respective owners.



This integrated circuit can be damaged by ESD. Texas Instruments recommends that all integrated circuits be handled with appropriate precautions. Failure to observe proper handling and installation procedures can cause damage.

ESD damage can range from subtle performance degradation to complete device failure. Precision integrated circuits may be more susceptible to damage because very small parametric changes could cause the device not to meet its published specifications.

### ORDERING INFORMATION

For the most current package and ordering information, see the Package Option Addendum at the end of this document, or visit the device product folder at [ti.com](http://ti.com).

### ABSOLUTE MAXIMUM RATINGS<sup>(1)</sup>

Over operating free-air temperature range, unless otherwise noted.

	ADS7924	UNIT
Supply voltage, AVDD to AGND	-0.3 to +6	V
Supply voltage, DVDD to DGND	-0.3 to +6	V
Supply voltage, DVDD to AVDD	AVDD ≥ DVDD	V
AGND to DGND	-0.3 to +0.3	V
Analog input voltage	AGND - 0.3 to AVDD + 0.3	V
Digital input voltage with respect to DGND (SCL and SDA)	DGND - 0.3 to 6	V
Digital input voltage with respect to DGND (A0, RESET)	DGND - 0.3 to DVDD + 0.3	V
Input current to all pins except supply pins	-10 to +10	mA
Maximum operating temperature	+125	°C
Storage temperature range	-60 to +150	°C

(1) Stresses above these ratings may cause permanent damage. Exposure to absolute maximum conditions for extended periods may degrade device reliability. These are stress ratings only, and functional operation of the device at these or any other conditions beyond those specified is not implied.

### THERMAL INFORMATION

THERMAL METRIC <sup>(1)</sup>		ADS7924	UNITS
		RTE	
		16	
$\theta_{JA}$	Junction-to-ambient thermal resistance	48.1	°C/W
$\theta_{JC(top)}$	Junction-to-case(top) thermal resistance	47.3	
$\theta_{JB}$	Junction-to-board thermal resistance	60.8	
$\psi_{JT}$	Junction-to-top characterization parameter	0.3	
$\psi_{JB}$	Junction-to-board characterization parameter	14.1	
$\theta_{JC(bottom)}$	Junction-to-case(bottom) thermal resistance	0.4	

(1) For more information about traditional and new thermal metrics, see the *IC Package Thermal Metrics* application report, [SPRA953](http://spraq953).

## ELECTRICAL CHARACTERISTICS

Minimum/maximum specifications are at  $T_A = -40^\circ\text{C}$  to  $+85^\circ\text{C}$ ,  $1.65\text{V} < \text{DVDD} < 5.5\text{V}$ , and  $2.2\text{V} < \text{AVDD} < 5.5\text{V}$ . Typical specifications are at  $T_A = +25^\circ\text{C}$ ,  $\text{AVDD} = 5\text{V}$ , and  $\text{DVDD} = 5\text{V}$ , unless otherwise noted.

PARAMETER	TEST CONDITIONS	ADS7924			UNIT
		MIN	TYP	MAX	
<b>ANALOG INPUT</b>					
Full-scale input span	(CHX – AGND)	0		AVDD	V
Input capacitance <sup>(1)</sup>			4	10	pF
ADC sampling capacitance			15		pF
MUX resistance			60		$\Omega$
Input channel crosstalk			85		dB
<b>SYSTEM PERFORMANCE</b>					
Resolution			12		Bits
No missing codes		12			Bits
Integral linearity		-1.5	$\pm 0.5$	1.5	LSBs
Differential linearity		-1.0	$\pm 0.6$	1.5	LSBs
Offset error		-5		5	LSBs
Offset error drift			0.01		LSB/ $^\circ\text{C}$
Gain error		-0.20	-0.01	0.20	%
Gain error drift			0.6		ppm/ $^\circ\text{C}$
Noise (rms)			0.125		LSB
<b>SAMPLING DYNAMICS</b>					
Monitoring time/channel <sup>(2)</sup>			10		$\mu\text{s}$
<b>CLOCK</b>					
Internal clock frequency variation			$\pm 20$		%
<b>DIGITAL INPUT/OUTPUT</b>					
Logic family			CMOS		
Logic level:					
$V_{IH}$ (SDA, SCL, A0, $\overline{\text{RESET}}$ )		0.8 DVDD		DVDD + 0.3	V
$V_{IL}$ (SDA, SCL, A0, $\overline{\text{RESET}}$ )		DGND – 0.3		0.4	V
Input current $I_i$	$V_i = \text{DVDD}$ or DGND	-10		10	$\mu\text{A}$
$V_{OH}$ (PWRCON, $\overline{\text{INT}}$ )	$I_{OH} = 100\mu\text{A}$ , $\overline{\text{INT}}$ pin	0.8 DVDD		DVDD	V
	$I_{OH} = 100\mu\text{A}$ , PWRCON pin	0.8 AVDD		AVDD	V
$V_{OL}$ (PWRCON, $\overline{\text{INT}}$ , SDA)	$I_{OL} = 100\mu\text{A}$	DGND		0.4	V
Low-level output current $I_{OL}$	SDA pin, $V_{OL} = 0.6\text{V}$			3	mA
Load capacitance $C_B$	SDA pin			400	pF
Data format			Straight binary		
<b>POWER-SUPPLY REQUIREMENTS</b>					
Power-supply voltage:					
DVDD <sup>(3)</sup>		1.65		5.5	V
AVDD		2.2		5.5	V
$I_{AVDD}$ <sup>(4)</sup>	$t_{\text{CYCLE}} = 2.5\text{ms}$ , $\text{AVDD} = 2.2\text{V}$		5	8	$\mu\text{A}$
$I_{\text{PWRD}}$ , power-down current			<1		$\mu\text{A}$
<b>TEMPERATURE RANGE</b>					
Specified performance		-40		+85	$^\circ\text{C}$

(1) CH0 to CH3 input pin capacitance.

(2) Rate at which channels can be scanned. This is the minimum acquisition time (6 $\mu\text{s}$ ) and conversion time (4 $\mu\text{s}$ ).

(3) DVDD cannot exceed AVDD.

(4) See [Figure 3](#) and [Figure 4](#) for more information.

### PIN CONFIGURATION

RTE PACKAGE  
QFN-16  
(TOP VIEW)

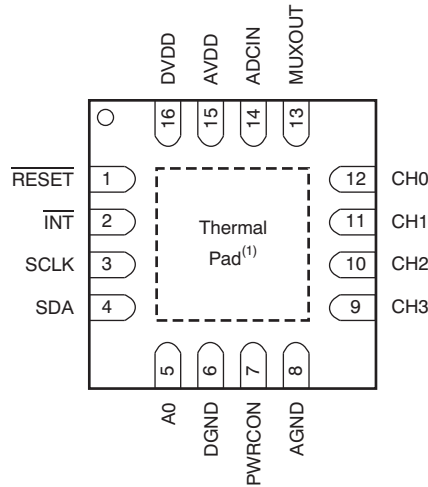

(1) Connect to AGND.

### TERMINAL FUNCTIONS

PIN NUMBER	NAME	FUNCTION	DESCRIPTION
1	$\overline{\text{RESET}}$	Digital input	External reset, active low
2	$\overline{\text{INT}}$	Digital output	Interrupt pin, active low; generated when input voltage is beyond programmed threshold
3	SCLK	Digital input	Serial clock input
4	SDA	Digital input/output	Serial data
5	A0	Digital input	I <sup>2</sup> C address selection
6	DGND	Digital	Digital ground
7	PWRCON	Digital output	Power control pin to control shutdown/power-up of external op amp
8	AGND	Analog	Analog ground
9	CH3	Analog input	Input channel 3
10	CH2	Analog input	Input channel 2
11	CH1	Analog input	Input channel 1
12	CH0	Analog input	Input channel 0
13	MUXOUT	Analog output	Multiplexer output
14	ADCIN	Analog input	ADC input
15	AVDD	Analog	Analog supply
16	DVDD	Digital	Digital supply

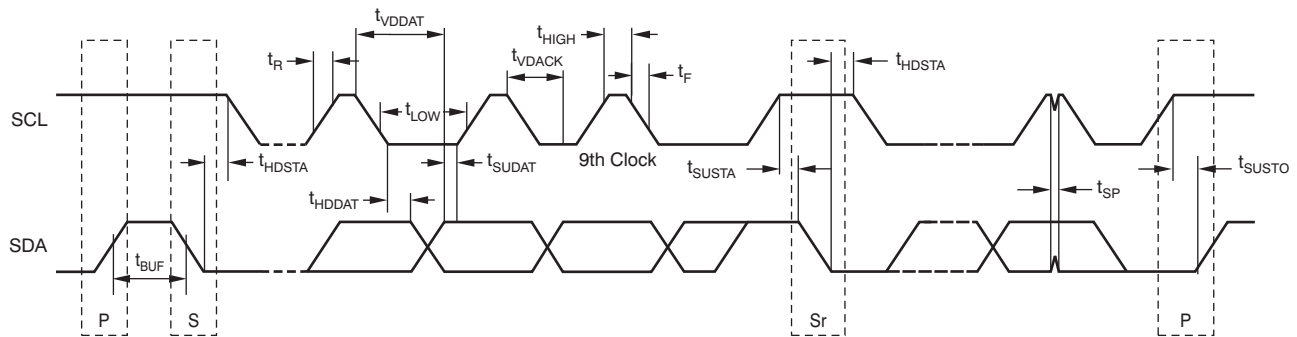
**TIMING DIAGRAM**

NOTE: S = Start, Sr = Repeated Start, and P = Stop.

**Figure 1. I<sup>2</sup>C Timing Diagram**

**Table 1. I<sup>2</sup>C Timing Definitions**

PARAMETER		ADS7924		UNIT
		MIN	MAX	
SCL operating frequency	$f_{SCL}$	0	0.4	MHz
Bus free time between START and STOP condition	$t_{BUF}$	1.3		$\mu$ s
Hold time after repeated START condition. After this period, the first clock is generated.	$t_{HDSTA}$	600		ns
Repeated START condition setup time	$t_{SUSTA}$	600		ns
Stop condition setup time	$t_{SUSTO}$	600		ns
Data hold time	$t_{HDDAT}$	0		ns
Data setup time	$t_{SUDAT}$	100		ns
SCL clock low period	$t_{LOW}$	1300		ns
SCL clock high period	$t_{HIGH}$	600		ns
Clock/data fall time	$t_F$		300	ns
Clock/data rise time	$t_R$		300	ns
Data valid time	$t_{VDDAT}$		0.9	$\mu$ s
Data valid acknowledge time	$t_{VDACK}$		0.9	$\mu$ s
Pulse width of spike that must be suppressed by the input filter	$t_{SP}$	0	50	ns

### TYPICAL CHARACTERISTICS

At  $T_A = +25^\circ\text{C}$ , unless otherwise noted.

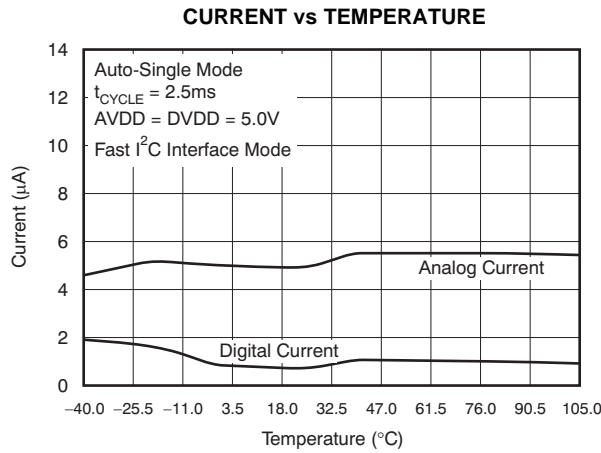

Figure 2.

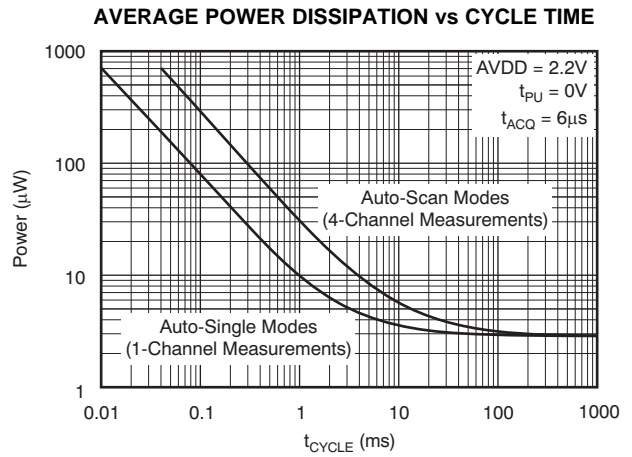

Figure 3.

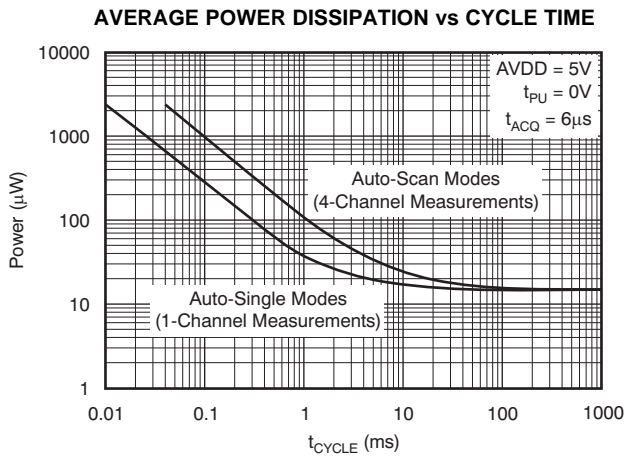

Figure 4.

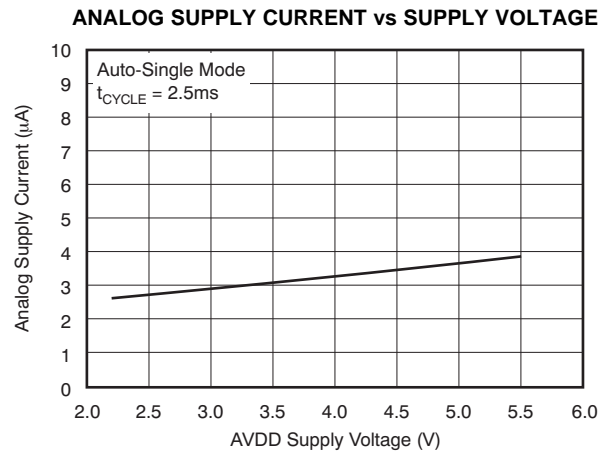

Figure 5.

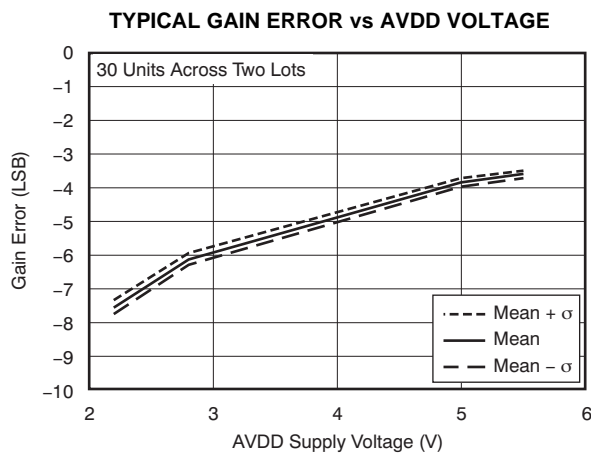

Figure 6.

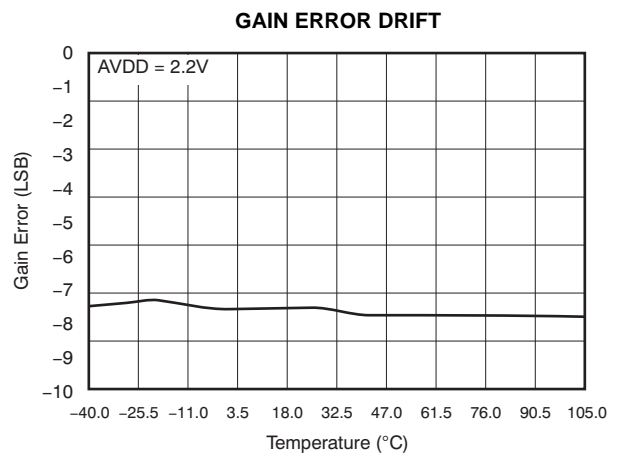
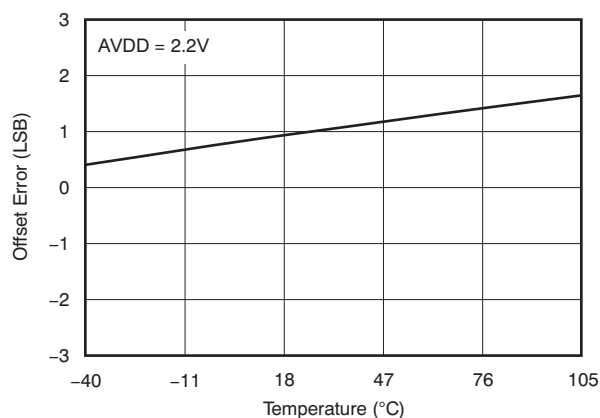

Figure 7.

**TYPICAL CHARACTERISTICS (continued)**

At  $T_A = +25^\circ\text{C}$ , unless otherwise noted.

**OFFSET ERROR DRIFT, TYPICAL**



**Figure 8.**

**TYPICAL OFFSET ERROR vs AVDD VOLTAGE**

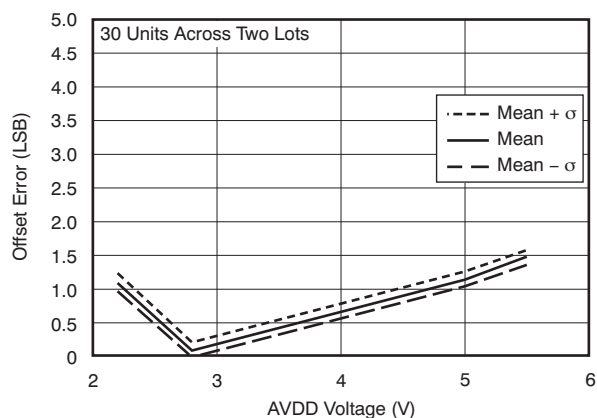

**Figure 9.**

**INTERNAL OSCILLATOR FREQUENCY vs VOLTAGE**

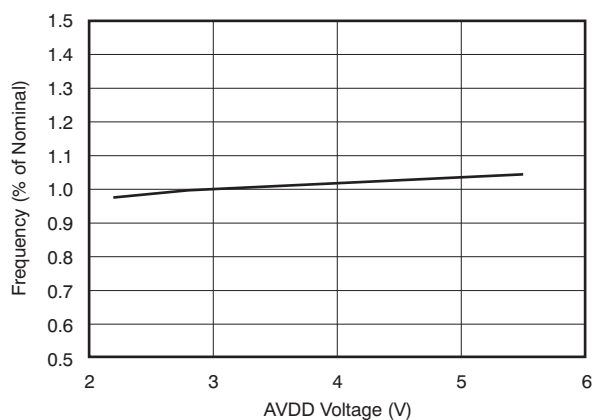

**Figure 10.**

**INTEGRAL NONLINEARITY**

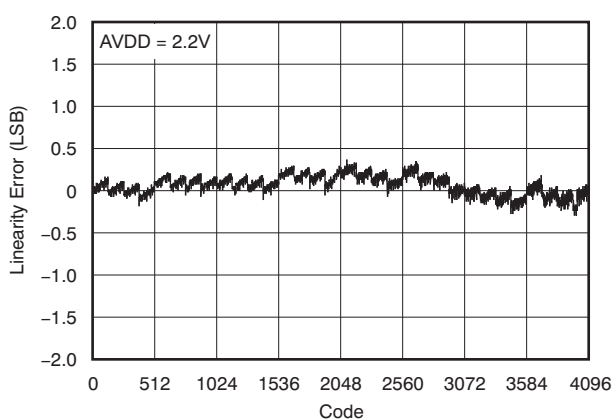

**Figure 11.**

**INTEGRAL NONLINEARITY**

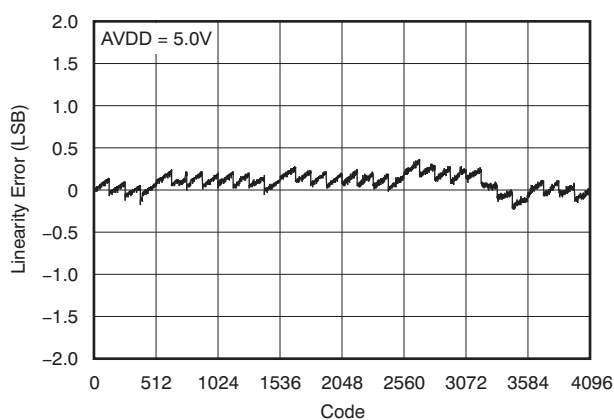

**Figure 12.**

**INTEGRAL LINEARITY ERROR DRIFT**

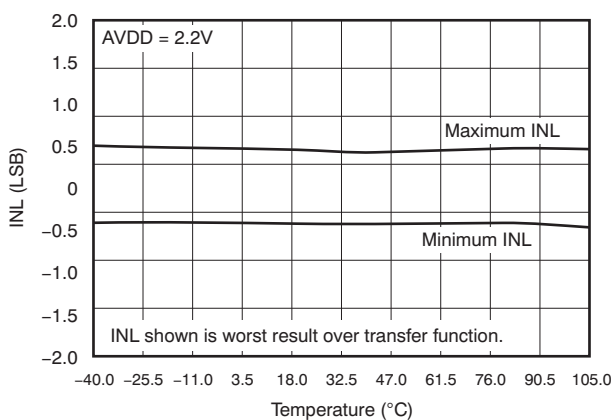
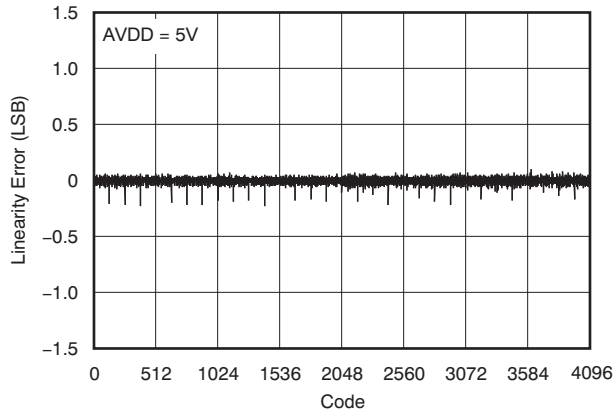

**Figure 13.**

**TYPICAL CHARACTERISTICS (continued)**

At  $T_A = +25^\circ\text{C}$ , unless otherwise noted.

**DIFFERENTIAL NONLINEARITY**



**Figure 14.**

**DIFFERENTIAL NONLINEARITY**

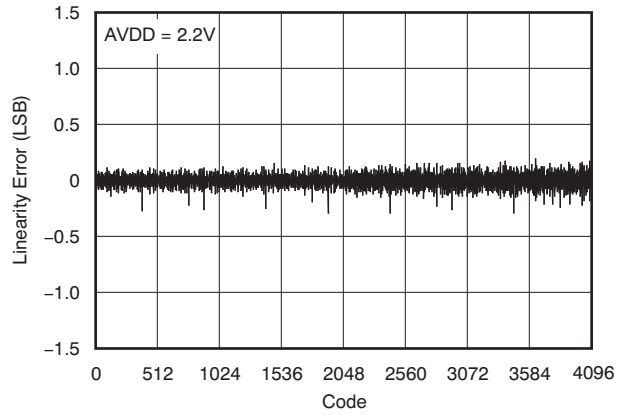

**Figure 15.**

**DIFFERENTIAL NONLINEARITY vs TEMPERATURE**

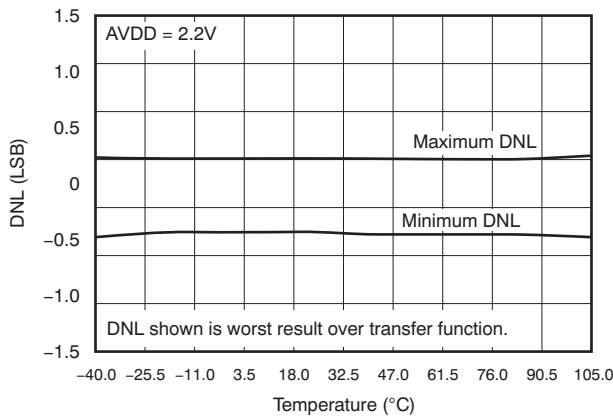

**Figure 16.**

**NOISE HISTOGRAM<sup>(1)</sup>**

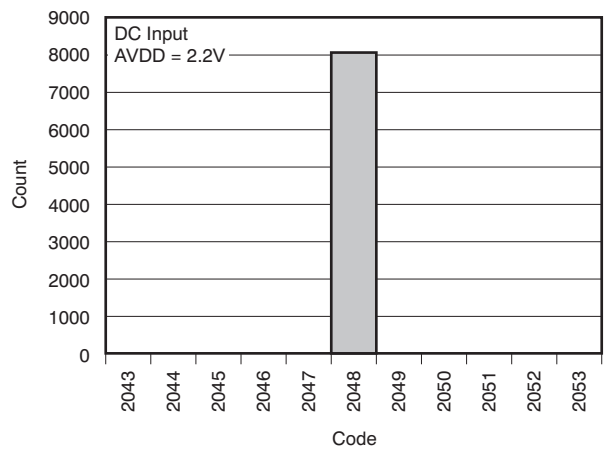

**Figure 17.**

**NOISE HISTOGRAM<sup>(1)</sup>**

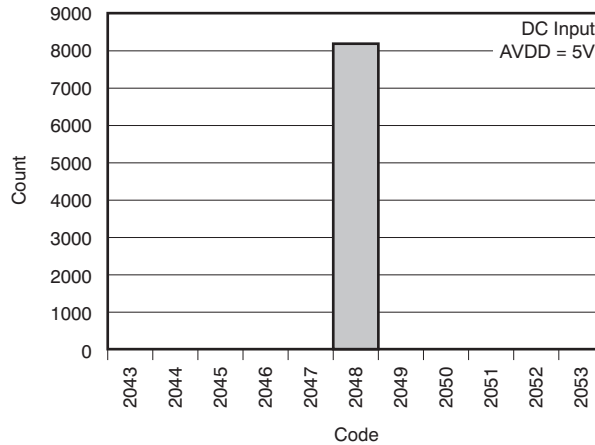

**Figure 18.**

(1) At code center.

## OVERVIEW

The ADS7924 is a miniature, four-channel, multiplexed, 12-bit, analog-to-digital converter (ADC) with an I<sup>2</sup>C serial interface. Figure 19 shows a block diagram. The four-channel input multiplexer is routed through external pins to allow a common signal conditioning block to be used for all four channels. The PWRCON digital output can be used to shut down active circuitry used in the signal conditioning; see the [Application Information](#) section for additional details.

The successive-approximation-register (SAR) ADC performs a no-latency conversion on the selected input channel and stores the data in a dedicated register. A digital threshold comparator with programmable upper and lower limits can be enabled and used to create an alarm monitor. A dedicated interrupt output pin (INT) indicates when an alarm occurs. Two I<sup>2</sup>C addresses are available and are selected with the dedicated digital input pin A0. Both standard and fast mode formats for I<sup>2</sup>C are supported.

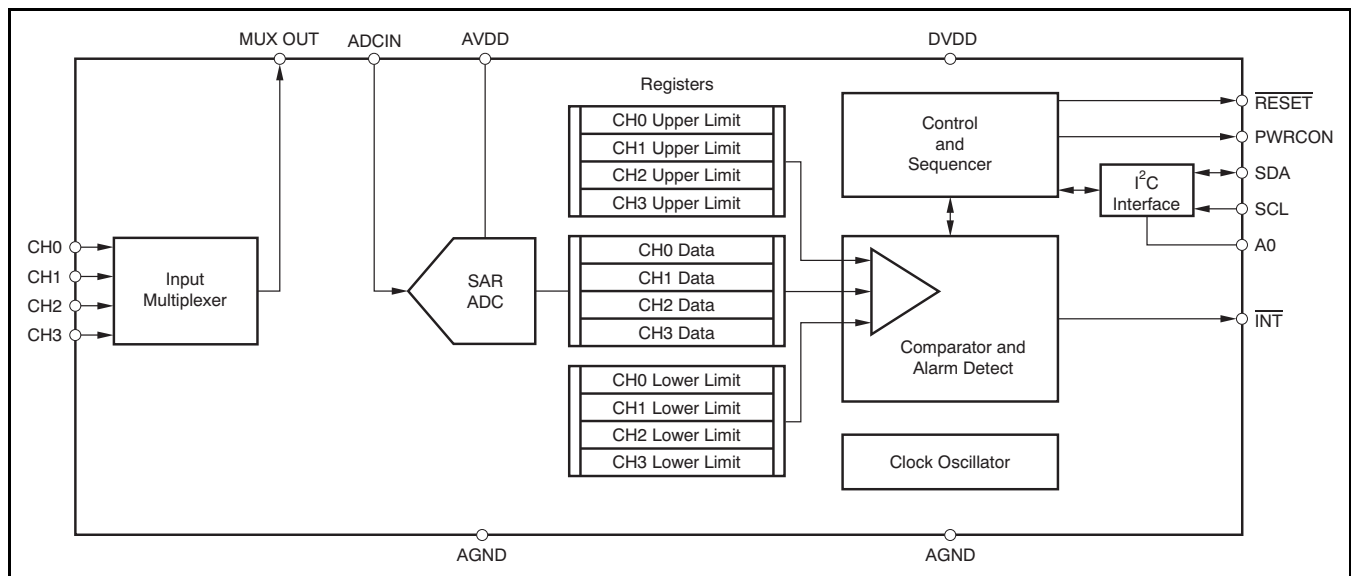

**Figure 19. ADS7924 Block Diagram**

### MULTIPLEXER

The ADS7924 has a four-channel, single-ended input multiplexer. As Figure 20 shows, ESD diodes protect the inputs. Make sure these diodes do not turn on by staying within the absolute input voltage range specification. The MUXOUT pin can be connected to AGND within the multiplexer; for example, to provide a test signal of 0V or as part of a calibration procedure. See the *PWRCONFIG: Power Configuration* register in the *Register Map* section for more details

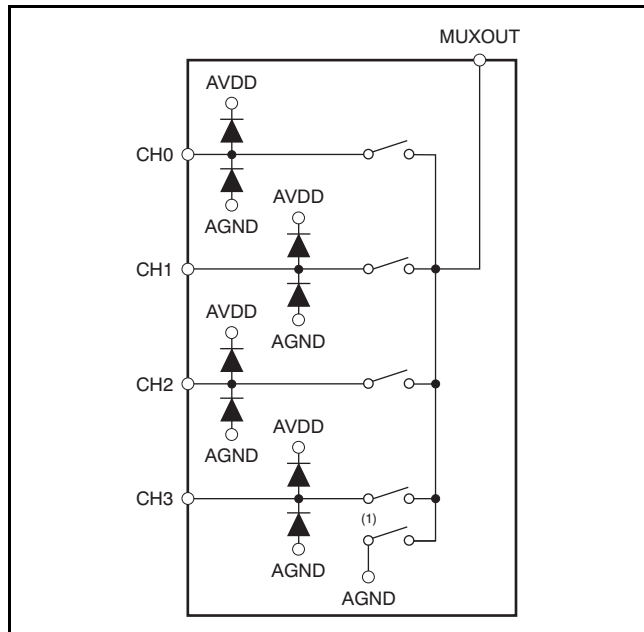

(1) See the *PWRCONFIG: Power Configuration* register in the *Register Map* section.

**Figure 20. ADS7924 Multiplexer**

### ADC INPUT

The ADCIN pin provides a single-ended input to the 12-bit successive approximation register (SAR) ADC. This pin is protected with ESD diodes in the same way as the multiplexer inputs. While acquiring the signal during the  $t_{ACQ}$  interval, the ADC sampling

capacitor is connected to the ADCIN pin. While converting during the  $t_{CONV}$  interval, the sampling capacitor is disconnected from the ADCIN pin, and the conversion process determines the voltage that was sampled.

### REFERENCE

The analog supply voltage (AVDD) is used as the reference. Power to the ADS7924 should be clean and well bypassed. A 0.1µF ceramic capacitor should be placed as close as possible to the ADS7924 package. In addition, a 1µF to 10µF capacitor and a 5Ω to 10Ω series resistor may be used to low-pass filter a noisy supply.

### CLOCK

The ADS7924 uses an internal clock. The clock speed determines the various timing settings such as conversion time, acquisition time, etc.

### DATA FORMAT

The ADS7924 provides 12 bits of data in unipolar format. The positive full-scale input produces an output code of FFFh and a zero input produces an output code of 0h. The output clips at these codes for signals that either exceed full-scale or go below '0'. Figure 21 shows code transitions versus input voltage.

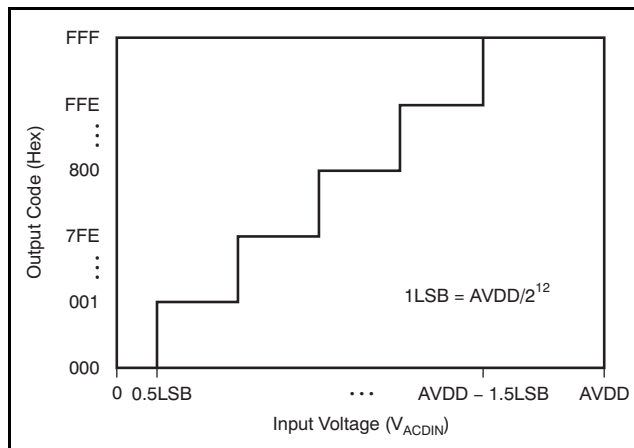

(1) Excludes the effects of noise, INL, offset, and gain errors.

**Figure 21. ADS7924 Code Transition Diagram<sup>(1)</sup>**

## ADC CONVERSION TIMING

The ADS7924 provides a flexible timing arrangement to support a wide variety of measurement needs. Three user-controlled timings include power up ( $t_{PU}$ ), acquisition ( $t_{ACQ}$ ), and sleep ( $t_{SLEEP}$ ) plus a fixed conversion time ( $t_{CONV}$ ).

### Power-Up Time

The power-up time is allowed to elapse whenever the device has been shutdown in idle mode. Power-up time can allow external circuits, such as an op amp, between the MUXOUT and ADCIN pins to turn on. The nominal time programmed by the PUTIME[4:0] register bits is given by [Equation 1](#):

$$t_{PU} = \text{PWRUPTIME}[4:0] \times 2\mu\text{s} \quad (1)$$

For example, if PWRUPTIME is set to 25 ('011001') then 50 $\mu\text{s}$  is allowed to elapse before beginning the acquisition time. If a power-up time is not required, set the bits to '0' to effectively bypass.

### Acquisition Time

The acquisition time is allowed to elapse before beginning a conversion. During this time, the ADC acquires the signal. The minimum acquisition time is 6 $\mu\text{s}$ . The nominal time programmed by the ACQTIME[4:0] register bits is given by [Equation 2](#):

$$t_{ACQ} = (\text{ACQTIME}[4:0] \times 2\mu\text{s}) + 6\mu\text{s} \quad (2)$$

For example, if ACQTIME is set to 30 ('011110') then 66 $\mu\text{s}$  is allowed to acquire the input signal. If an acquisition time greater than 6 $\mu\text{s}$  is not required, set the bits to '0'.

### Conversion Time

The conversion time is always 4 $\mu\text{s}$  and cannot be programmed by the user.

## Sleep Time

The sleep time is allowed to elapse after conversions in the Auto-Single with Sleep, Auto-Scan with Sleep, and Auto-Burst Scan with Sleep modes. The nominal time programmed by the SLPTIME registers can be increased by a factor of eight using the SLPMULT8 bit or decreased by a factor of four using the SLPDIV4 bit.

## INTERRUPT OUTPUT ( $\overline{\text{INT}}$ )

The ADS7924 offers a dedicated output pin ( $\overline{\text{INT}}$ ) for signaling an interrupt condition. The  $\overline{\text{INT}}$  pin can be configured to activate when the ADC is busy with a conversion, when data are ready for retrieval, or when an alarm condition occurs; see the Interrupt Configuration register in the [Register Map](#) section.

To clear an interrupt from an alarm condition, read the INTCONFIG register (12h). To clear an interrupt from data ready, read the data registers. The interrupt clears when the lower four bits are retrieved.

The  $\overline{\text{INT}}$  pin can be configured to generate a static output (useful for a host controller monitoring for a level) or a pulse output (useful for a host controller monitoring for an edge transition). When a pulse output is selected, the nominal pulse width is 250ns. The Interrupt Control Register should be read to clear the interrupt.

## PWRCON

The PWRCON pin allows the user to synchronize the shutdown/wakeup of an external op amp with the ADC conversion cycle. This feature provides further power reduction and can be useful in applications where the time difference between consecutive signal captures is large. The PWRCON pin can drive up to 3mA of current and its output voltage is the same as AVDD. This pin is controlled by the PWRCONFIG register.

## ALARM

The ADS7924 offers an independent alarm function for each input channel. An 8-bit window comparator can be enabled to test the ADC conversion result against an upper limit set by the ULR register and against a lower limit set by the LLR register. If the conversion result is less than or equal to the LLR threshold value or greater than or equal to the ULR threshold value, the comparator is tripped. There are separate upper and lower registers for each input channel.

A programmable counter determines how many comparator trips it takes to generate an alarm. A separate counter is used for each channel and is incremented whenever the comparator trips, either for the upper or lower thresholds. That is, an ADC conversion result on channel 1 that exceeds the ULR threshold or falls below the LLR threshold increments the counter for that channel. Figure 22 shows a conceptual diagram of the window comparator and alarm circuitry.

When an alarm occurs, the  $\overline{\text{INT}}$  pin can be configured to generate an interrupt. The channel that generated the alarm can be read from the registers. A read of the Interrupt Control register clears the alarm register and also resets the alarm counter.

## ADC OPERATING MODES

The ADS7924 offers multiple operating modes to support a wide variety of monitoring needs. Conversions can either be started manually or set to automatically continue. The mode is set by writing to the MODE register, and changes take effect as soon as the write completes. Table 2 gives a brief description of each mode.

### Idle Mode

Use this mode to save power when not converting. All circuits are shut down.

### Awake Mode

All circuits are operating in this mode and the ADC is ready to convert. When switching between modes, be sure to first select the Awake mode and then switch to the desired mode. This procedure ensures the internal control logic is properly synchronized.

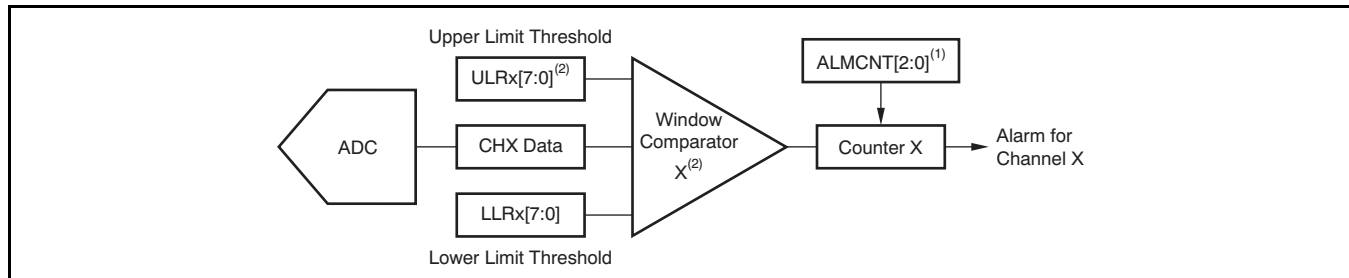

(1) The same ALMCNT value is used for all four window comparators.

(2) X = 0 to 3.

Figure 22. Window Comparator/Alarm Conceptual Block Diagram

Table 2. Mode Descriptions

MODE	DESCRIPTION
Idle	All circuits shutdown; lowest power setting
Awake	All circuits awake and ready to convert
Manual-Single	Select input channel is converted once
Manual-Scan	All input channels are converted once
Auto-Single	One input channel is continuously converted
Auto-Scan	All input channels are continuously converted
Auto-Single with Sleep	One input channel is continuously converted with programmable sleep time between conversions
Auto-Scan with Sleep	All input channels are continuously converted with programmable sleep time between conversions
Auto-Burst Scan with Sleep	All input channels are converted with minimal delay followed by a programmable sleep time

### Manual-Single Mode

This mode converts the selected channel once, as shown in Figure 23. After the ADC Mode Control register is written, the power-up time ( $t_{PU}$ ) and acquisition time ( $t_{ACQ}$ ) are allowed to elapse.  $t_{PU}$  can be set to '0' to effectively bypass if not needed.  $t_{ACQ}$  time is programmable through the ACQCONFIG register, bits[4:0]. Sleep time ( $t_{SLEEP}$ ) is not used in this mode.

After the conversion completes, the device waits for a new mode to be set. This mode can be set to Idle to save power. When  $t_{PU}$  and  $t_{ACQ}$  are very short, the very short conversion time needed allows a read register operation to be issued on the I<sup>2</sup>C bus immediately after the write operation that initiates this mode. It is important to note that  $t_{PU}$  only applies to the first manual-single command.

If multiple conversions are needed, the manual-single mode can be reissued without requiring the awake mode to be issued in between. Consecutive manual-single commands have no  $t_{PU}$  period.

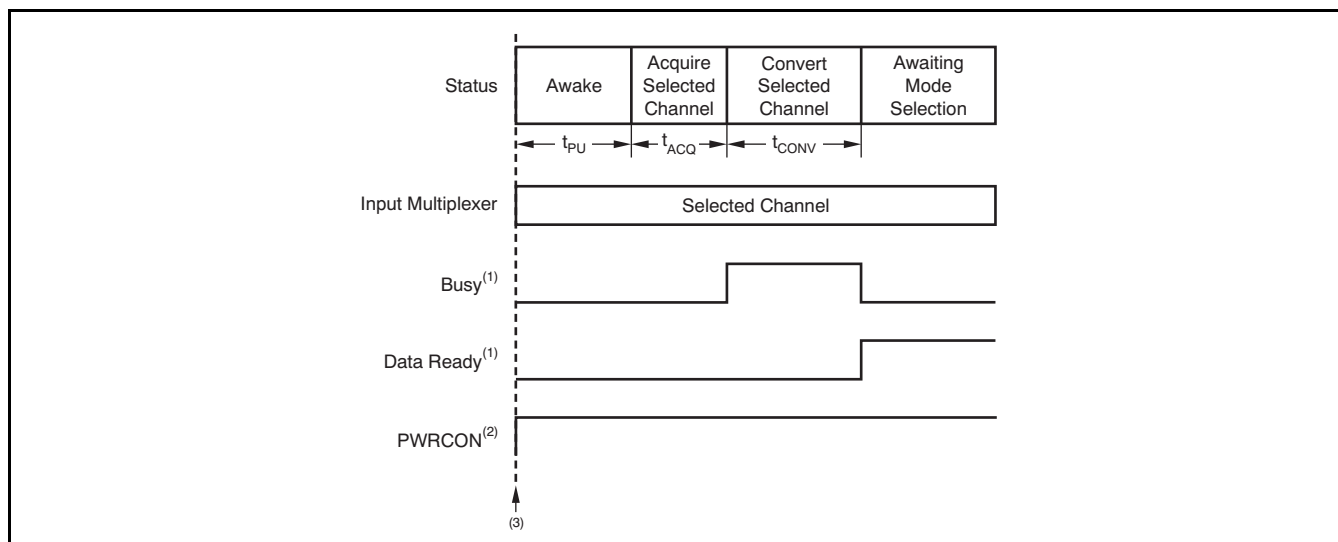

- (1) Busy and data ready are internal signals shown as active high that can be routed to the  $\overline{INT}$  pin for external monitoring.
- (2) PWRCON is shown enabled and active high.
- (3) The mode begins on the trailing edge of the I<sup>2</sup>C acknowledge after writing to the MODECNTL register.

**Figure 23. Manual-Single Operation Example**

### Manual-Scan Mode

This mode converts all of the channels once, starting with the selected channel, as illustrated in Figure 24. After the ADC Mode Control register is written, the power-up time ( $t_{PU}$ ) is allowed to elapse. This value can be set to '0' to effectively bypass if not needed. Before each conversion, an acquisition time ( $t_{ACQ}$ ) is allowed to elapse.  $t_{ACK}$  time is programmable through the ACQCONFIG register, bits[4:0]. Sleep time ( $t_{SLEEP}$ ) is not used in this mode. The input multiplexer is automatically incremented as the conversions complete. If, for example, the initial selected channel is CH2, the conversion order is CH2, CH3, CH0, and CH1. Data from the conversions are always put into the data register that corresponds to a particular channel. For example,

CH2 data always goes in register DATA2\_H and DATA2\_L regardless of conversion order. After all four conversions complete, the device waits for a new mode to be set. This mode can be set to Idle afterwards to save power. The  $\overline{INT}$  pin can be configured to indicate the completion of each individual conversion or it can wait until all four finish. In either case, the appropriate data register is updated after each conversion. These registers can be read at any time afterwards. If multiple scan are needed, the manual-scan mode can be reissued without requiring the Awake mode to be issued in between.

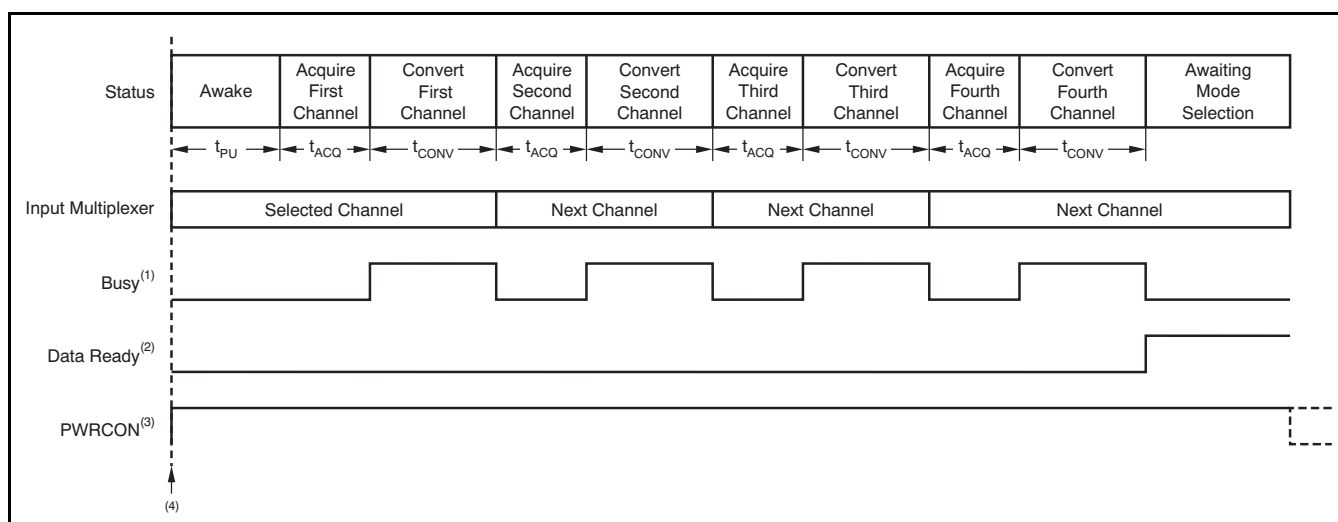

- (1) Busy is an internal signal shown as active high that can be routed to the  $\overline{INT}$  pin for external monitoring.
- (2) Data ready is an internal signal shown as active high and is enabled when all conversions are complete. It can be routed to the  $\overline{INT}$  pin for external monitoring.
- (3) PWRCON is shown enabled and active high.
- (4) The mode begins on the trailing edge of the I<sup>2</sup>C acknowledge after writing to the MODECNTL register.

**Figure 24. Manual-Scan Operation Example**

### Auto-Single Mode

This mode automatically converts the selected channel continuously, as shown in Figure 25. After the ADC Mode Control register is written, the power-up time ( $t_{PU}$ ) is allowed to elapse. This value can be set to '0' to effectively bypass if not needed. Before the conversion, an acquisition time ( $t_{ACQ}$ ) is allowed to elapse.  $t_{ACQ}$  time is programmable through the ACQCONFIG register, bits[4:0]. Sleep time ( $t_{SLEEP}$ ) is not used in this mode. After the conversion completes the cycle is repeated.

This mode can be used with the onboard digital comparator to monitor the status of an input signal with little support needed from a host microcontroller. Note that the conversion time is less than the I<sup>2</sup>C data retrieval time. It is suggested to stop this mode by setting the mode to Idle or stopping the conversion by configuring the alarm to do so, before retrieving data. The alarm can also be configured to continue the conversion even after an interrupt is generated.

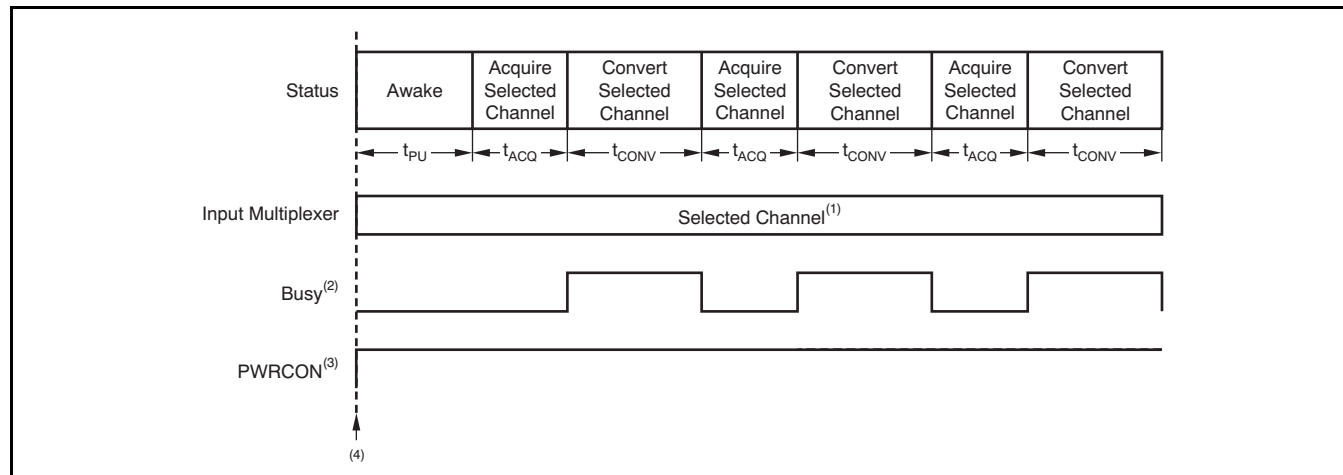

- (1) Same channel is continuously converted.
- (2) Busy is an internal signal shown as active high that can be routed to the  $\overline{INT}$  pin for external monitoring.
- (3) PWRCON is shown enabled and active high.
- (4) The mode begins on the trailing edge of the I<sup>2</sup>C acknowledge after writing to the MODECNTL register.

**Figure 25. Example of Auto-Single Operation**

### Auto-Scan Mode

This mode automatically converts all the channels continuously, starting with the selected channel, as illustrated in Figure 26. After the ADC Mode Control register is written, the power-up time ( $t_{PU}$ ) is allowed to elapse. This value can be set to '0' to effectively bypass if not needed. Before the conversion, an acquisition time ( $t_{ACQ}$ ) is allowed to elapse.  $t_{ACQ}$  time is programmable through the ACQCONFIG register, bits[4:0]. Sleep time ( $t_{SLEEP}$ ) is not used in this mode. The input multiplexer is automatically incremented as the conversions complete. If, for example, the initial selected channel is CH2, the conversion order is CH2, CH3, CH0, CH1, CH2, CH3, etc. until the mode

is stopped. Data from the conversions are always put into the data register that corresponds to a particular channel. For example, CH2 data always go in register DATA2\_H and DATA2\_L regardless of conversion order.

This mode can be used with the onboard digital comparator to monitor the status of the input signals with little support needed from a host microcontroller. It is suggested to interrupt this mode and stop the automatic conversions, either by setting the mode to Idle or configuring the alarm to do so, before retrieving data.

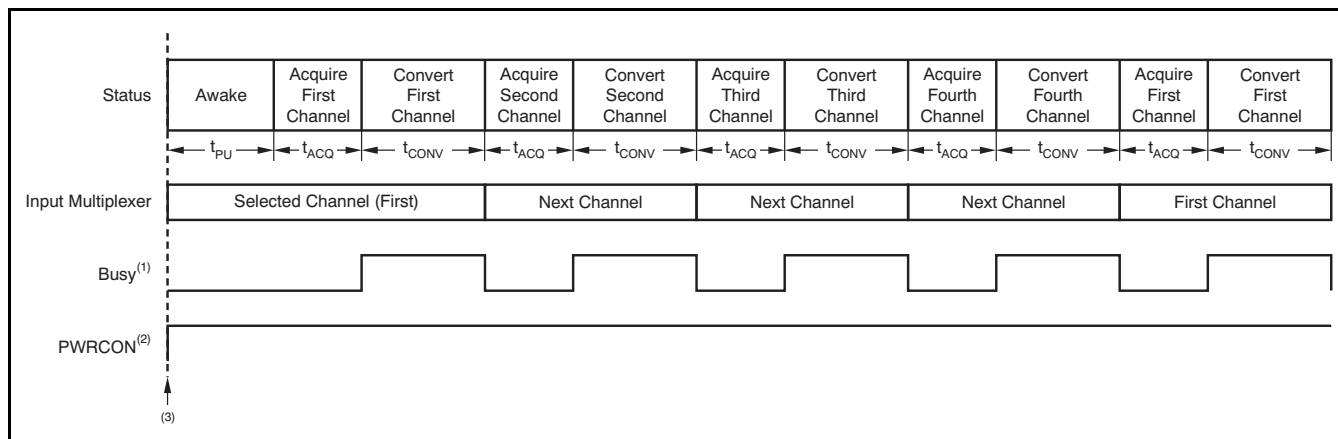

- (1) Busy is an internal signal shown as active high that can be routed to the  $\overline{INT}$  pin for external monitoring.
- (2) PWRCON is shown enabled and active high.
- (3) The mode begins on the trailing edge of the I<sup>2</sup>C acknowledge after writing to the MODECNTL register.

**Figure 26. Auto-Scan Operation Example**

### Auto-Single with Sleep Mode

This mode automatically converts the selected channel repeatedly with a sleep interval between conversions, as shown in Figure 27. After the ADC Mode Control register is written, the power-up time ( $t_{PU}$ ) is allowed to elapse. This value can be set to '0' to effectively bypass if not needed. Before the conversion, an acquisition time ( $t_{ACQ}$ ) is allowed to elapse.  $t_{ACQ}$  time is programmable through the ACQCONFIG register, bits[4:0]. After the conversion, sleep time ( $t_{SLEEP}$ ) is allowed to elapse and then the cycle repeats. The length of the sleep time is controlled by register bits. During the sleep mode, power dissipation is minimal and the PWRCON output is always disabled.

This mode can be used with the onboard digital comparator to periodically monitor the status of an input signal while saving power between conversions. Little support is needed from a host microcontroller. It is suggested to stop this mode by setting the mode to Idle or stopping the conversion by configuring the alarm to do so, before retrieving data. The length in time of the cycle ( $t_{CYCLE}$ ) sets the average power dissipation, as shown in Figure 3 or Figure 4.

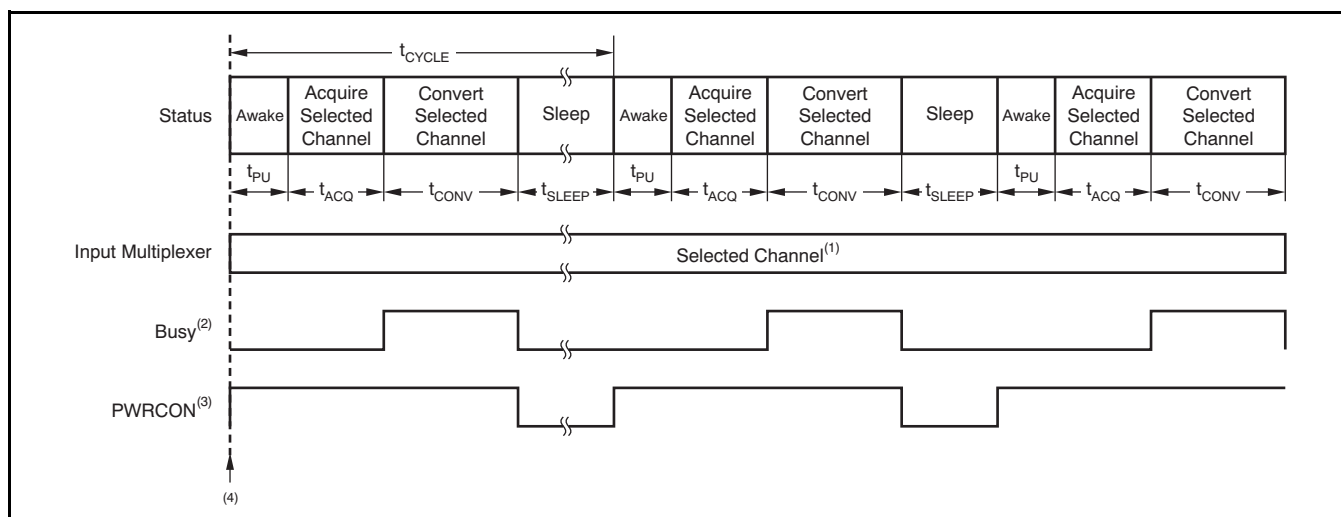

- (1) Same channel is continuously converted.
- (2) Busy is an internal signal shown as active high that can be routed to the  $\overline{INT}$  pin for external monitoring.
- (3) PWRCON is shown enabled and active high.
- (4) The mode begins on the trailing edge of the I<sup>2</sup>C acknowledge after writing to the MODECNTL register.

**Figure 27. Auto-Single with Sleep Operation Example**

### Auto-Scan with Sleep Mode

This mode automatically converts all the channels repeatedly with a sleep interval between conversions, as illustrated in Figure 28. After the ADC Mode Control register is written, the power-up time ( $t_{PU}$ ) is allowed to elapse. This value can be set to '0' to effectively bypass if not needed. Before the first conversion of the selected input, an acquisition time ( $t_{ACQ}$ ) is allowed to elapse.  $t_{ACQ}$  time is programmable through the ACQCONFIG register, bits[4:0]. After the conversion, a sleep time ( $t_{SLEEP}$ ) is allowed to elapse and then the cycle repeats. The length of the sleep time is controlled by register bits. During the sleep mode, power dissipation is minimal and the PWRCON output is always disabled. The input multiplexer is automatically incremented as the conversions complete. If, for example, the initial selected channel is CH2, the conversion order is CH2, CH3, CH0, CH1, CH2, CH3, etc. until the mode

is stopped. Data from the conversions are always put into the data register that corresponds to a particular channel. For example, CH2 data always goes in register DATA2\_H and DATA2\_L regardless of conversion order.

This mode can be used with the onboard digital comparator to periodically monitor the status of the input signals while saving power between conversions. Little support is needed from a host microcontroller. It is suggested to stop this mode by setting the mode to Idle or stopping the conversion by configuring the alarm to do so, before retrieving data. The length in time of the cycle ( $t_{CYCLE}$ ) sets the average power dissipation, as shown in Figure 3 or Figure 4.

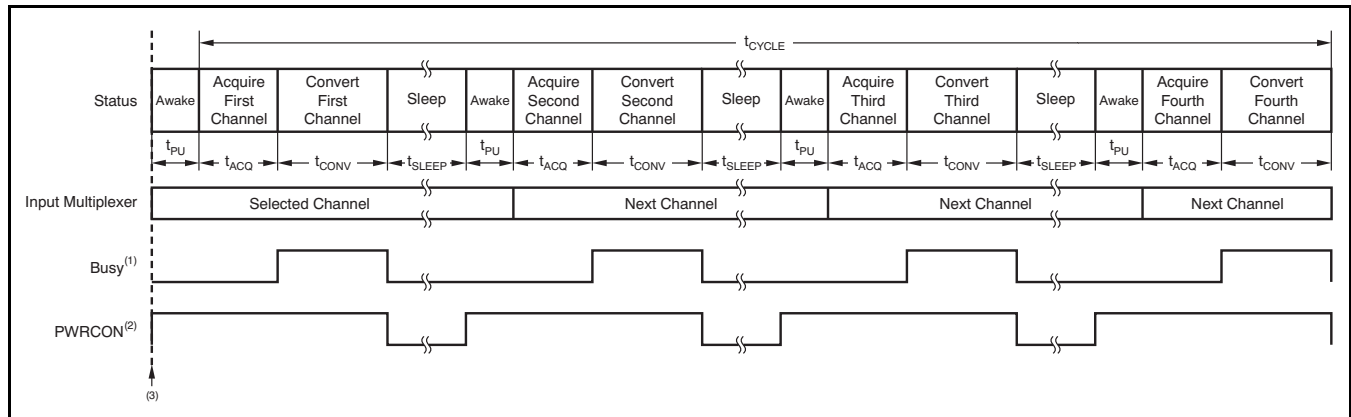

- (1) Busy is an internal signal shown as active high that can be routed to the  $\overline{INT}$  pin for external monitoring.
- (2) PWRCON is shown enabled and active high.
- (3) The mode begins on the trailing edge of the I<sup>2</sup>C acknowledge after writing to the MODECNTL register.

**Figure 28. Auto-Scan with Sleep Operation Example**

### Auto-Burst Scan with Sleep Mode

This mode automatically converts all the channels without delay followed by a sleep interval before the cycle repeats, as shown in Figure 29. After the ADC Mode Control register is written, the power-up time ( $t_{PU}$ ) is allowed to elapse. This value can be set to '0' to effectively bypass if not needed. Before the first conversion of the selected input, an acquisition time ( $t_{ACQ}$ ) is allowed to elapse.  $t_{ACQ}$  time is programmable through the ACQCONFIG register, bits[4:0]. Afterwards, all four inputs are measured without delay. The input multiplexer is automatically incremented as the conversions complete. If, for example, the initial selected channel is CH2, the conversion order is CH2, CH3, CH0, and CH1. After the four conversions, a sleep time ( $t_{SLEEP}$ ) is allowed to elapse and then the cycle repeats. The length of the sleep time is controlled by register bits. During the sleep mode, power dissipation is minimal and the

PWRCON output is always disabled. Data from the conversions are always put into the data register that corresponds to a particular channel. For example, CH2 data always goes in register DATA2\_H and DATA2\_L regardless of conversion order.

This mode can be used with the onboard digital comparator to periodically monitor the status of the input signals while saving power between conversions. Little support is needed from a host microcontroller. It is suggested to interrupt this mode and stop the automatic conversions, either by setting the mode to Idle or configuring the alarm to do so, before retrieving data. The length in time of the cycle ( $t_{CYCLE}$ ) sets the average power, as shown in Figure 3 or Figure 4.

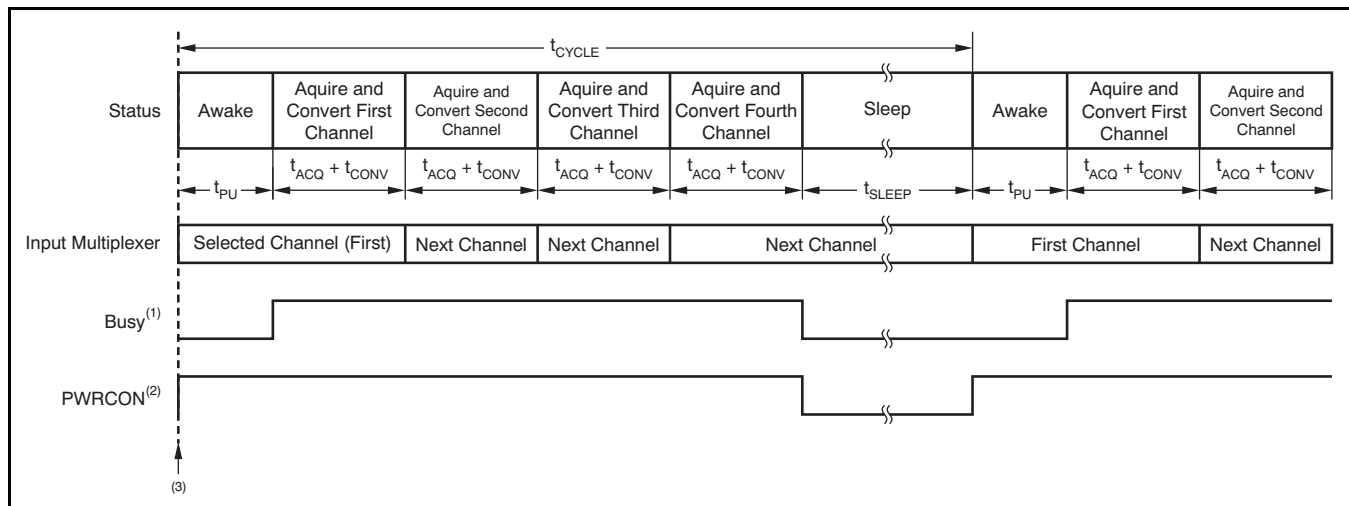

- (1) Busy is an internal signal shown as active high that can be routed to the  $\overline{INT}$  pin for external monitoring.
- (2) PWRCON is shown enabled and active high.
- (3) The mode begins on the trailing edge of the I<sup>2</sup>C acknowledge after writing to the MODECNTL register.

Figure 29. Auto-Burst Scan with Sleep Operation Example

## REGISTER MAP

The ADS7924 operation is controlled through a set of registers. Collectively, the registers contain all the information needed to configure the part. [Table 3](#) shows the register map.

**Table 3. Register Map**

ADDRESS	REGISTER	RESET VALUE	BIT 7	BIT 6	BIT 5	BIT 4	BIT 3	BIT 2	BIT 1	BIT 0
00h	MODECNTRL	00h	MODE5	MODE4	MODE3	MODE2	MODE1	MODE0	SEL/ID1	SEL/ID0
01h	INTCNTRL	X0h	ALRM_ST3	ALRM_ST2	ALRM_ST1	ALRM_ST0	AEN/ST3	AEN/ST2	AEN/ST1	AEN/ST0
02h	DATA0_U	XXh	DATA0[11]	DATA0[10]	DATA0[9]	DATA0[8]	DATA0[7]	DATA0[6]	DATA0[5]	DATA0[4]
03h	DATA0_L	XXh	DATA0[3]	DATA0[2]	DATA0[1]	DATA0[0]	0	0	0	0
04h	DATA1_U	XXh	DATA1[11]	DATA1[10]	DATA1[9]	DATA1[8]	DATA1[7]	DATA1[6]	DATA1[5]	DATA1[4]
05h	DATA1_L	XXh	DATA1[3]	DATA1[2]	DATA1[1]	DATA1[0]	0	0	0	0
06h	DATA2_U	XXh	DATA2[11]	DATA2[10]	DATA2[9]	DATA2[8]	DATA2[7]	DATA2[6]	DATA2[5]	DATA2[4]
07h	DATA2_L	XXh	DATA2[3]	DATA2[2]	DATA2[1]	DATA2[0]	0	0	0	0
08h	DATA3_U	XXh	DATA3[11]	DATA3[10]	DATA3[9]	DATA3[8]	DATA3[7]	DATA3[6]	DATA3[5]	DATA3[4]
09h	DATA3_L	XXh	DATA3[3]	DATA3[2]	DATA3[1]	DATA3[0]	0	0	0	0
0Ah	ULR0	XXh	ULR0[7]	ULR0[6]	ULR0[5]	ULR0[4]	ULR0[3]	ULR0[2]	ULR0[1]	ULR0[0]
0Bh	LLR0	XXh	LLR0[7]	LLR0[6]	LLR0[5]	LLR0[4]	LLR0[3]	LLR0[2]	LLR0[1]	LLR0[0]
0Ch	ULR1	XXh	ULR1[7]	ULR1[6]	ULR1[5]	ULR1[4]	ULR1[3]	ULR1[2]	ULR1[1]	ULR1[0]
0Dh	LLR1	XXh	LLR1[7]	LLR1[6]	LLR1[5]	LLR1[4]	LLR1[3]	LLR1[2]	LLR1[1]	LLR1[0]
0Eh	ULR2	XXh	ULR2[7]	ULR2[6]	ULR2[5]	ULR2[4]	ULR2[3]	ULR2[2]	ULR2[1]	ULR2[0]
0Fh	LLR2	XXh	LLR2[7]	LLR2[6]	LLR2[5]	LLR2[4]	LLR2[3]	LLR2[2]	LLR2[1]	LLR2[0]
10h	ULR3	XXh	ULR3[7]	ULR3[6]	ULR3[5]	ULR3[4]	ULR3[3]	ULR3[2]	ULR3[1]	ULR3[0]
11h	LLR3	XXh	LLR3[7]	LLR3[6]	LLR3[5]	LLR3[4]	LLR3[3]	LLR3[2]	LLR3[1]	LLR3[0]
12h	INTCONFIG	E0h	AIMCNT2	AIMCNT1	AIMCNT0	INTCNFG1	INTCNFG0	BUSY/ $\overline{\text{INT}}$	INTPOL	INTTRIG
13h	SLPCONFIG	00h	0	CONVCTRL	SLPDIV4	SLPMULT8	0	SLPTIME2	SLPTIME1	SLPTIME0
14h	ACQCONFIG	00h	0	0	0	ACQTIME4	ACQTIME3	ACQTIME2	ACQTIME1	ACQTIME0
15h	PWRCONFIG	00h	CALCNTL	PWRCONPOL	PWRCONEN	PWRUPTIME4	PWRUPTIME3	PWRUPTIME2	PWRUPTIME1	PWRUPTIME0
16h	RESET	18h (A0 = 0) 19h (A0 = 1)	RST/ID7	RST/ID6	RST/ID5	RST/ID4	RST/ID3	RST/ID2	RST/ID1	RST/ID0

**MODECNTRL: ADC Mode Control Register (Address = 00h)**

7	6	5	4	3	2	1	0
MODE5	MODE4	MODE3	MODE2	MODE1	MODE0	SEL/ID1	SEL/ID0

**Bits[7:2] MODE[5:0]: Mode control**

000000 = Idle mode (default)  
 100000 = Awake mode  
 110000 = Manual-Single mode  
 110010 = Manual-Scan mode  
 110001 = Auto-Single mode  
 110011 = Auto-Scan mode  
 111001 = Auto-Single with Sleep mode  
 111011 = Auto-Scan with Sleep mode  
 111111 = Auto-Burst Scan with Sleep mode

**Bits[1:0] SEL/ID[1:0]: Channel selection**

When read, these bits indicate the last channel converted.  
 When writing to these bits, select which input appears on MUXOUT:  
 00 = Channel 0 is selected  
 01 = Channel 1 is selected  
 10 = Channel 2 is selected  
 11 = Channel 3 is selected (unless the CALCNTL bit is set to '1')

**INTCNTRL: Interrupt Control Register (Address = 01h)**

7	6	5	4	3	2	1	0
ALRM_ST3	ALRM_ST2	ALRM_ST1	ALRM_ST0	AEN/ST3	AEN/ST2	AEN/ST1	AEN/ST0

**Bits[7:4] ALRM\_ST[3:0]: Alarm status (read-only)**

Reading these bits indicates the alarm status for the channels. These bits are never masked—they always report the alarm status even when the alarm is not enabled by the corresponding AEN/ST bits.  
 Bit 7 = Channel 3 alarm status, '1' indicates an alarm condition  
 Bit 6 = Channel 2 alarm status, '1' indicates an alarm condition  
 Bit 5 = Channel 1 alarm status, '1' indicates an alarm condition  
 Bit 4 = Channel 0 alarm status, '1' indicates an alarm condition

**Bits[3:0] AEN/ST[3:0]: Alarm enable**

Writing to these bits enables the alarm for the corresponding channel.  
 Reading these bits returns the status of the alarm for the corresponding channel when enabled. Reading returns a '0' when the alarm is not enabled.  
 Bit 3 = Channel 3 alarm enable, 1 = enabled (default = 0)  
 Bit 2 = Channel 2 alarm enable, 1 = enabled (default = 0)  
 Bit 1 = Channel 1 alarm enable, 1 = enabled (default = 0)  
 Bit 0 = Channel 0 alarm enable, 1 = enabled (default = 0)

There are individual registers for each input channel to buffer the conversion data. The 12 bits are stored in two registers: the upper register stores the eight most significant bits; the lower register stores the lower four least significant bits. The data registers are always updated with the corresponding input channel regardless of the order of conversion. For example, DATA0\_U and DATA0\_L always contain the results of the latest conversion of CH0.

**DATA0\_U: Conversion Data for Channel 0, Upper Bits Register (Address = 02h)**

7	6	5	4	3	2	1	0
DATA0[11] (MSB)	DATA0[10]	DATA0[9]	DATA0[8]	DATA0[7]	DATA0[6]	DATA0[5]	DATA0[4]

**DATA0\_L: Conversion Data for Channel 0, Lower Bits Register (Address = 03h)**

7	6	5	4	3	2	1	0
DATA0[3]	DATA0[2]	DATA0[1]	DATA0[0] (LSB)	0	0	0	0

**DATA1\_U: Conversion Data for Channel 1, Upper Bits Register (Address = 04h)**

7	6	5	4	3	2	1	0
DATA1[11] (MSB)	DATA1[10]	DATA1[9]	DATA1[8]	DATA1[7]	DATA1[6]	DATA1[5]	DATA1[4]

**DATA1\_L: Conversion Data for Channel 1, Lower Bits Register (Address = 05h)**

7	6	5	4	3	2	1	0
DATA1[3]	DATA1[2]	DATA1[1]	DATA1[0] (LSB)	0	0	0	0

**DATA2\_U: Conversion Data for Channel 2, Upper Bits Register (Address = 06h)**

7	6	5	4	3	2	1	0
DATA2[11] (MSB)	DATA2[10]	DATA2[9]	DATA2[8]	DATA2[7]	DATA2[6]	DATA2[5]	DATA2[4]

**DATA2\_L: Conversion Data for Channel 2, Lower Bits Register (Address = 07h)**

7	6	5	4	3	2	1	0
DATA2[3]	DATA2[2]	DATA2[1]	DATA2[0] (LSB)	0	0	0	0

**DATA3\_U: Conversion Data for Channel 3, Upper Bits Register (Address = 08h)**

7	6	5	4	3	2	1	0
DATA3[11] (MSB)	DATA3[10]	DATA3[9]	DATA3[8]	DATA3[7]	DATA3[6]	DATA3[5]	DATA3[4]

**DATA3\_L: Conversion Data for Channel 3, Lower Bits Register (Address = 09h)**

7	6	5	4	3	2	1	0
DATA3[3]	DATA3[2]	DATA3[1]	DATA3[0] (LSB)	0	0	0	0

There are individual upper and lower threshold registers for input channel. Each register is eight bits with the least significant bit weight equal to AVDD/256. The comparator is tripped when the input signal exceeds the value of the upper limit register or falls below the lower limit register.

**ULR0: Upper Limit Threshold for Channel 0 Comparator Register (Address = 0Ah)**

7	6	5	4	3	2	1	0
ULR0[7] (MSB)	ULR0[6]	ULR0[5]	ULR0[4]	ULR0[3]	ULR0[2]	ULR0[1]	ULR0[0] (LSB)

**LLR0: Lower Limit Threshold for Channel 0 Comparator Register (Address = 0Bh)**

7	6	5	4	3	2	1	0
LLR0[7] (MSB)	LLR0[6]	LLR0[5]	LLR0[4]	LLR0[3]	LLR0[2]	LLR0[1]	LLR0[0] (LSB)

**ULR1: Upper Limit Threshold for Channel 1 Comparator Register (Address = 0Ch)**

7	6	5	4	3	2	1	0
ULR1[7] (MSB)	ULR1[6]	ULR1[5]	ULR1[4]	ULR1[3]	ULR1[2]	ULR1[1]	ULR1[0] (LSB)

**LLR1: Lower Limit Threshold for Channel 1 Comparator Register (Address = 0Dh)**

7	6	5	4	3	2	1	0
LLR1[7] (MSB)	LLR1[6]	LLR1[5]	LLR1[4]	LLR1[3]	LLR1[2]	LLR1[1]	LLR1[0] (LSB)

**ULR2: Upper Limit Threshold for Channel 2 Comparator Register (Address = 0Eh)**

7	6	5	4	3	2	1	0
ULR2[7] (MSB)	ULR2[6]	ULR2[5]	ULR2[4]	ULR2[3]	ULR2[2]	ULR2[1]	ULR2[0] (LSB)

**LLR2: Lower Limit Threshold for Channel 2 Comparator Register (Address = 0Fh)**

7	6	5	4	3	2	1	0
LLR2[7] (MSB)	LLR2[6]	LLR2[5]	LLR2[4]	LLR2[3]	LLR2[2]	LLR2[1]	LLR2[0] (LSB)

**ULR3: Upper Limit Threshold for Channel 3 Comparator Register (Address = 10h)**

7	6	5	4	3	2	1	0
ULR3[7] (MSB)	ULR3[6]	ULR3[5]	ULR3[4]	ULR3[3]	ULR3[2]	ULR3[1]	ULR3[0] (LSB)

**LLR3: Lower Limit Threshold for Channel 3 Comparator Register (Address = 11h)**

7	6	5	4	3	2	1	0
LLR3[7] (MSB)	LLR3[6]	LLR3[5]	LLR3[4]	LLR3[3]	LLR3[2]	LLR3[1]	LLR3[0] (LSB)

**INTCONFIG: Interrupt Configuration Register (Address = 12h)**

7	6	5	4	3	2	1	0
ALMCNT2	ALMCNT1	ALMCNT0	INTCNFG2	INTCNFG1	INTCNFG0	INTPOL	INTRIG

**Bits[7:5] ALMCNT[2:0]: Alarm count**

These bits set the number of times the comparator threshold limit (either upper or lower) must be exceeded to generate an alarm.

- 000 = Every conversion generates an alarm
- 010 = Exceeding the threshold limit 1 time generates an alarm condition
- 100 = Exceeding the threshold limit 2 times generates an alarm condition
- 110 = Exceeding the threshold limit 3 times generates an alarm condition
- 111 = Exceeding the threshold limit 4 times generates an alarm condition
- 101 = Exceeding the threshold limit 5 times generates an alarm condition
- 110 = Exceeding the threshold limit 6 times generates an alarm condition
- 111 = Exceeding the threshold limit 7 times generates an alarm condition

**Bits[4:2] INTCNFG[2:0]:  $\overline{\text{INT}}$  output pin configuration**

These bits determine which signal is output on  $\overline{\text{INT}}$ . They also select the conversion control event; see the CONVCTRL bit in the SLPCONFIG register. The configuration of these bits is shown in [Table 4](#).

**Table 4.  $\overline{\text{INT}}$  Pin Configuration**

BIT SETTING	$\overline{\text{INT}}$ PIN CONFIGURATION	CONVERSION CONTROL EVENT
000	Alarm	Alarm
001	Busy	Alarm
010	Data ready: one conversion completed	Data ready: one conversion complete
011	Busy	Data ready: one conversion complete
100	Do not use	—
101	Do not use	—
110	Data ready: all four conversions complete	Data ready: four conversions complete
111	Busy	Data ready: four conversions complete

**Bit 1 INTPOL:  $\overline{\text{INT}}$  pin polarity**

- 0 = Active low (default)
- 1 = Active high

**Bit 0 INTRIG:  $\overline{\text{INT}}$  output pin signaling**

- 0 = Static signal for use with level triggering (default)
- 1 = Pulse signal for use with edge triggering

**SLPCONFIG: Sleep Configuration Register (Address = 13h)**

7	6	5	4	3	2	1	0
0	CONVCTRL	SLPDIV4	SLPMULT8	0	SLPTIME2	SLPTIME1	SLPTIME0

**Bit 7** Always write '0'

**Bit 6** **CONVCTRL: Conversion control**

This bit determines the conversion status after a conversion control event; see the INTCNFG bits in the INTCONFIG register.

0 = Conversions continue, independent of the control event status (default)

1 = Conversions are stopped as soon as a control event occurs; the event must be cleared to resume conversions

**Bit 5** **SLPDIV4: Sleep time 4x divider**

This bit sets the speed of the sleep clock.

0 = Sleep time divider is '1' (default)

1 = Sleep time divider is '4'

**Bit 4** **SLPMULT8: Sleep time 8x multiplier**

0 = Sleep time multiplier is '1' (default)

1 = Sleep time multiplier is '8'

**Bit 3** Always write '0'

**Bits[2:0]** **SLPTIME[2:0]: Sleep time setting**

000 = 2.5ms (default)

001 = 5ms

010 = 10ms

011 = 20ms

100 = 40ms

101 = 80ms

110 = 160ms

111 = 320ms

**ACQCONFIG: Acquire Configuration Register (Address = 14h)**

7	6	5	4	3	2	1	0
0	0	0	ACQTIME4	ACQTIME3	ACQTIME2	ACQTIME1	ACQTIME0

**Bits[7:5]** Always write '0'

**Bits[4:0]** ACQTIME[4:0]: Signal acquire time

These bits set the time to acquire the signal before a conversion (default = 0).  
 $t_{ACQ} = ACQTIME[4:0] \times 2\mu s + 6\mu s$

**PWRCONFIG: Power-Up Configuration Register (Address = 15h)**

7	6	5	4	3	2	1	0
CALCNTL	PWRCONPOL	PWRCONEN	PWRUPTIME4	PWRUPTIME3	PWRUPTIME2	PWRUPTIME1	PWRUPTIME0

**Bit 7** CALCNTL: Calibration control

0 = Setting CH3 in the Mode Control register selects the CH3 input to be routed to the MUXOUT pin. (default)  
 1 = Setting CH3 in the Mode Control register connects the MUXOUT pin to AGND.

**Bit 6** PWRCONPOL: PWRCON pin polarity

0 = Active low (default)  
 1 = Active high

**Bit 5** PWRCONEN: PWRCON enable

0 = The PWRCON pin is disabled (default)  
 1 = The PWRCON pin is always enabled

**Bits[4:0]** PWRUPTIME[4:0]: Power-up time setting

These bits set the power-up time (default = 0).  
 $t_{PWR} = PWRUPTIME[4:0] \times 2\mu s$ .

**RESET: Software Reset and Device ID Register (Address = 16h)**

7	6	5	4	3	2	1	0
RST/ID7	RST/ID6	RST/ID5	RST/ID4	RST/ID3	RST/ID2	RST/ID1	RST/ID0

A read of this register returns the device ID when A0 determines the last bit of the device ID (0001100A0).  
 A write to this register of 10101010 generates a software reset of the ADS7924.

## I<sup>2</sup>C INTERFACE

The ADS7924 communicates through an I<sup>2</sup>C interface. I<sup>2</sup>C is a two-wire, open-drain interface that supports multiple devices and masters on a single bus. Devices on the I<sup>2</sup>C bus only drive the bus lines low by connecting them to ground; they never drive the bus lines high. Instead, the bus wires are pulled high by pull-up resistors, so the bus wires are high when no device is driving them low. This way, two devices cannot conflict; if two devices drive the bus simultaneously, there is no driver contention.

Communication on the I<sup>2</sup>C bus always takes place between two devices, one acting as the master and the other as the slave. Both masters and slaves can read and write, but slaves can only do so under the direction of the master. Some I<sup>2</sup>C devices can act as masters or slaves, but the ADS7924 can only act as a slave device.

An I<sup>2</sup>C bus consists of two lines, SDA and SCL. SDA carries data; SCL provides the clock. All data are transmitted across the I<sup>2</sup>C bus in groups of eight bits. To send a bit on the I<sup>2</sup>C bus, the SDA line is driven to the appropriate level while SCL is low (a low on SDA indicates the bit is zero; a high indicates the bit is one). Once the SDA line settles, the SCL line is brought high, then low. This pulse on SCL clocks the SDA bit into the receiver shift register. If the I<sup>2</sup>C bus is held idle for more than 25ms, the bus times out.

The I<sup>2</sup>C bus is bidirectional: the SDA line is used for both transmitting and receiving data. When the master reads from a slave, the slave drives the data line; when the master sends to a slave, the master drives the data line. The master always drives the clock line. The ADS7924 never drives SCL, because it cannot act as a master. On the ADS7924, SCL is an input only.

Most of the time the bus is idle; no communication occurs, and both lines are high. When communication is taking place, the bus is active. Only master devices can start a communication and initiate a START condition on the bus. Normally, the data line is only allowed to change state while the clock line is low. If the data line changes state while the clock line is high, it is either a START condition or a STOP condition. A START condition occurs when the clock line is high and the data line goes from high to low. A STOP condition occurs when the clock line is high and the data line goes from low to high.

After the master issues a START condition, it sends a byte that indicates which slave device it wants to communicate with. This byte is called the *address byte*. Each device on an I<sup>2</sup>C bus has a unique 7-bit address to which it responds. The master sends an address in the address byte, together with a bit that indicates whether it wishes to read from or write to the slave device.

Every byte transmitted on the I<sup>2</sup>C bus, whether it is address or data, is acknowledged with an *acknowledge* bit. When the master has finished sending a byte (eight data bits) to a slave, it stops driving SDA and waits for the slave to acknowledge the byte. The slave acknowledges the byte by pulling SDA low. The master then sends a clock pulse to clock the acknowledge bit. Similarly, when the master has finished reading a byte, it pulls SDA low to acknowledge this to the slave. It then sends a clock pulse to clock the bit. (The master always drives the clock line.)

A *not-acknowledge* is performed by simply leaving SDA high during an acknowledge cycle. If a device is not present on the bus, and the master attempts to address it, it receives a not-acknowledge because no device is present at that address to pull the line low.

When the master has finished communicating with a slave, it may issue a STOP condition. When a STOP condition is issued, the bus becomes idle again. The master may also issue another START condition. When a START condition is issued while the bus is active, it is called a repeated START condition.

See the [Timing Diagrams](#) section for a timing diagram showing the ADS7924 I<sup>2</sup>C transaction.

## I<sup>2</sup>C ADDRESS SELECTION

The ADS7924 has one address pin, A0, that sets the I<sup>2</sup>C address. This pin can be connected to ground or VDD, allowing two addresses to be selected with one pin as shown in [Table 5](#). The state of the address pin A0 is sampled continuously.

**Table 5. A0 Pin Connection and Corresponding Slave Address**

A0 PIN	SLAVE ADDRESS
Ground	1001000
DVDD	1001001

## I<sup>2</sup>C SPEED MODES

The ADS7924 supports the I<sup>2</sup>C standard and fast modes. Standard mode allows a clock frequency of up to 100kHz and fast mode permits a clock frequency of up to 400kHz.

## SLAVE MODE OPERATIONS

The ADS7924 can act as either slave receivers or slave transmitters. As a slave device, the ADS7924 cannot drive the SCL line.

**Receive Mode:**

In slave receive mode the first byte transmitted from the master to the slave is the address with the R/W bit low. This byte allows the slave to be written to. The next byte transmitted by the master is the register pointer byte. The ADS7924 then acknowledges receipt of the register pointer byte. The next two bytes are written to the address given by the register pointer. The ADS7924 acknowledges each byte sent. Register bytes are sent with the most significant byte first, followed by the least significant byte.

**Transmit Mode:**

In slave transmit mode, the first byte transmitted by the master is the 7-bit slave address followed by the high R/W bit. This byte places the slave into transmit mode and indicates that the ADS7924 is being read from. The next byte transmitted by the slave is the most significant byte of the register that is indicated by the register pointer. This byte is followed by an acknowledgment from the master. The remaining

least significant byte is then sent by the slave and is followed by an acknowledgment from the master. The master may terminate transmission after any byte by not acknowledging or issuing a START or STOP condition.

**WRITING THE REGISTERS**

To access a write register from the ADS7924, the master must first write the appropriate value to the Pointer address. The Pointer address is written directly after the slave address byte, low R/W bit, and a successful slave acknowledgment. After the Pointer address is written, the slave acknowledges and the master issues a STOP or a repeated START condition. The MSB of the pointer address is the increment (INC) bit. When set to '1', the register address is automatically incremented after every register write which allows convenient writing of multiple registers. Set INC to '0' when writing a single register. Figure 30 and Figure 31 show timing examples.

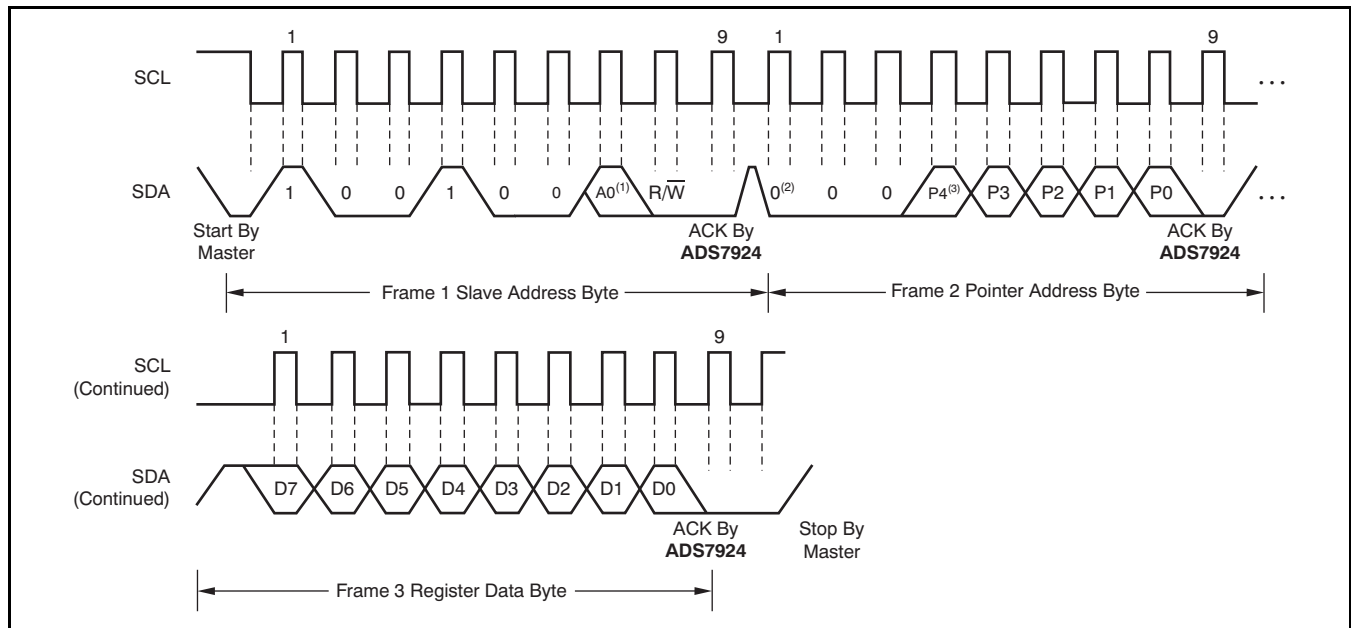

- (1) The value of A0 is determined by the A0 pin.
- (2) When INC is set to '0', the address pointer remains unchanged after a read.
- (3) Bits P[4:0] point to the register to be written.

**Figure 30. Writing a Single Register Timing Diagram**

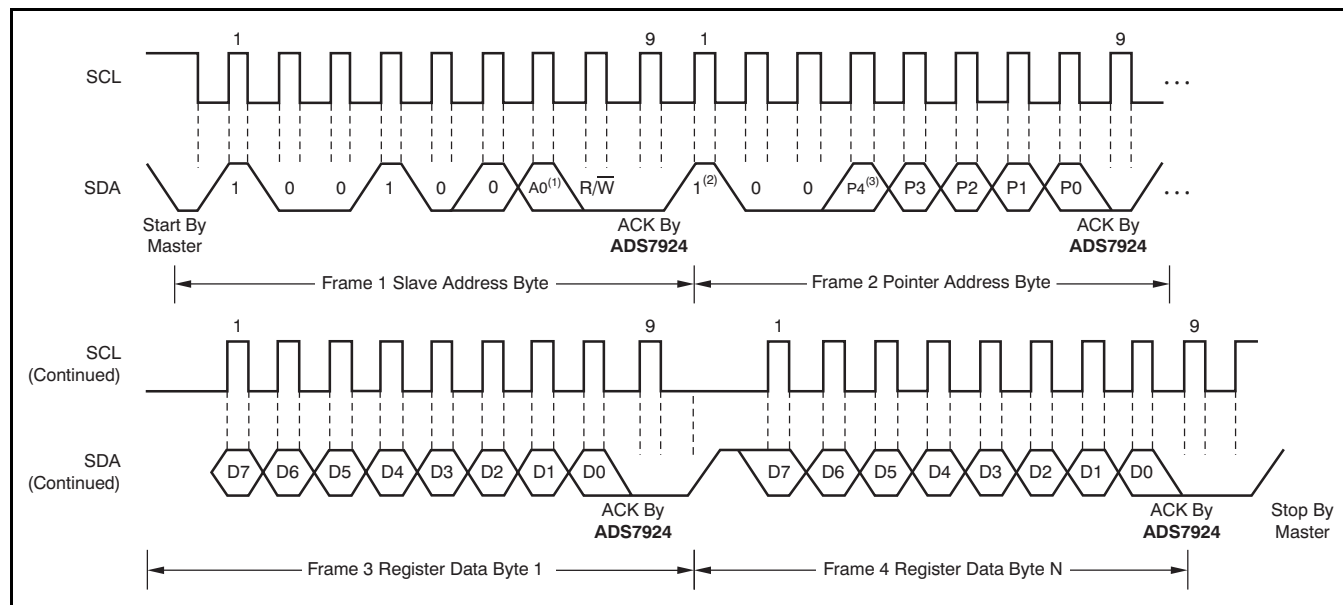

- (1) The value of A0 is determined by the A0 pin.
- (2) When INC is set to '1', the address pointer automatically increments for multiple register writes.
- (3) Bits P[4:0] point to the storing register to be written.

**Figure 31. Writing Multiple Registers Timing Diagram**

### READING THE REGISTERS

To read a specific register from the ADS7924, the master must first write the appropriate value to the pointer address. The pointer address is written directly after the slave address byte, low R/W bit, and a successful slave acknowledgment. The MSB of the pointer address is the INC bit. When set to '1', the register address is automatically incremented after every register read which allows convenient reading of multiple registers. Set INC to '0' when reading a single register.

The master may issue a START condition and send the slave address byte with the R/W bit high to begin the read. Note that if the previously selected register is to be read again there is no need to update the pointer address. Figure 32 to Figure 34 show examples of register reads.

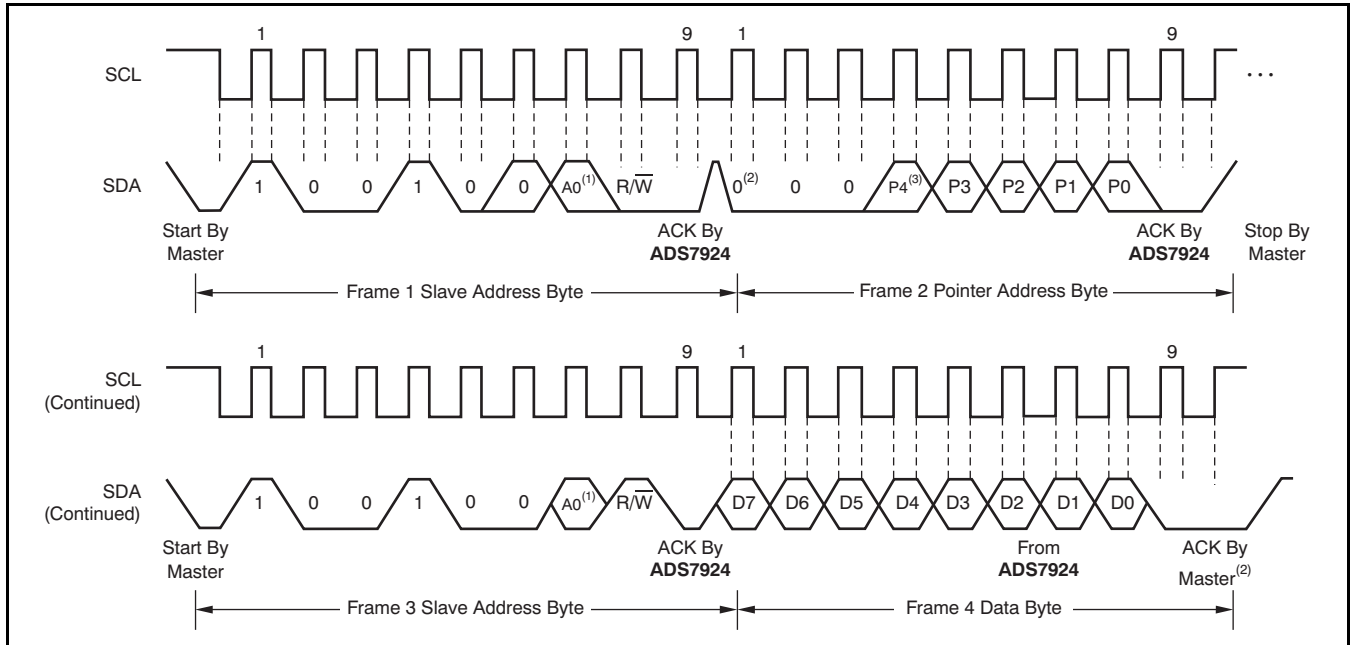

- (1) The value of A0 is determined by the A0 pin.
- (2) When INC is set to '0', the address pointer remains unchanged after a read.
- (3) Bits P[4:0] point to the register to be read.

**Figure 32. Reading a Single Register Timing Diagram**

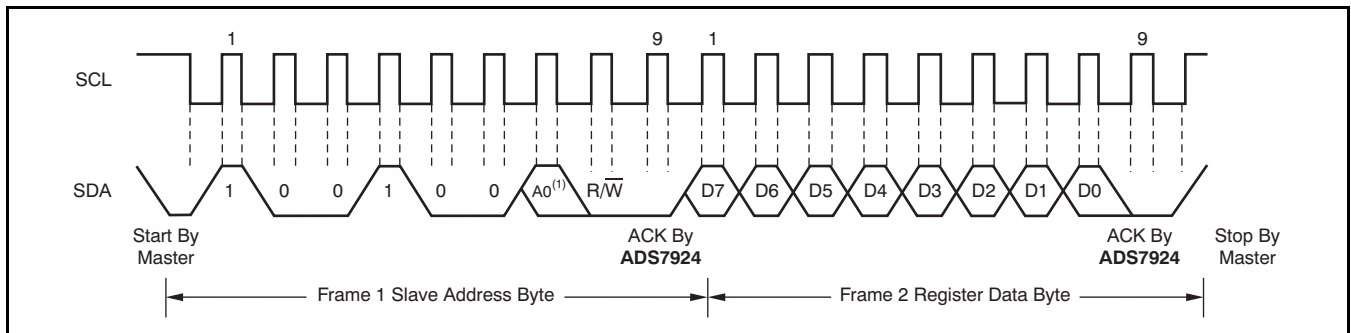

- (1) The value of A0 is determined by the A0 pin.

**Figure 33. Reading a Previously Addressed Register Timing Diagram**

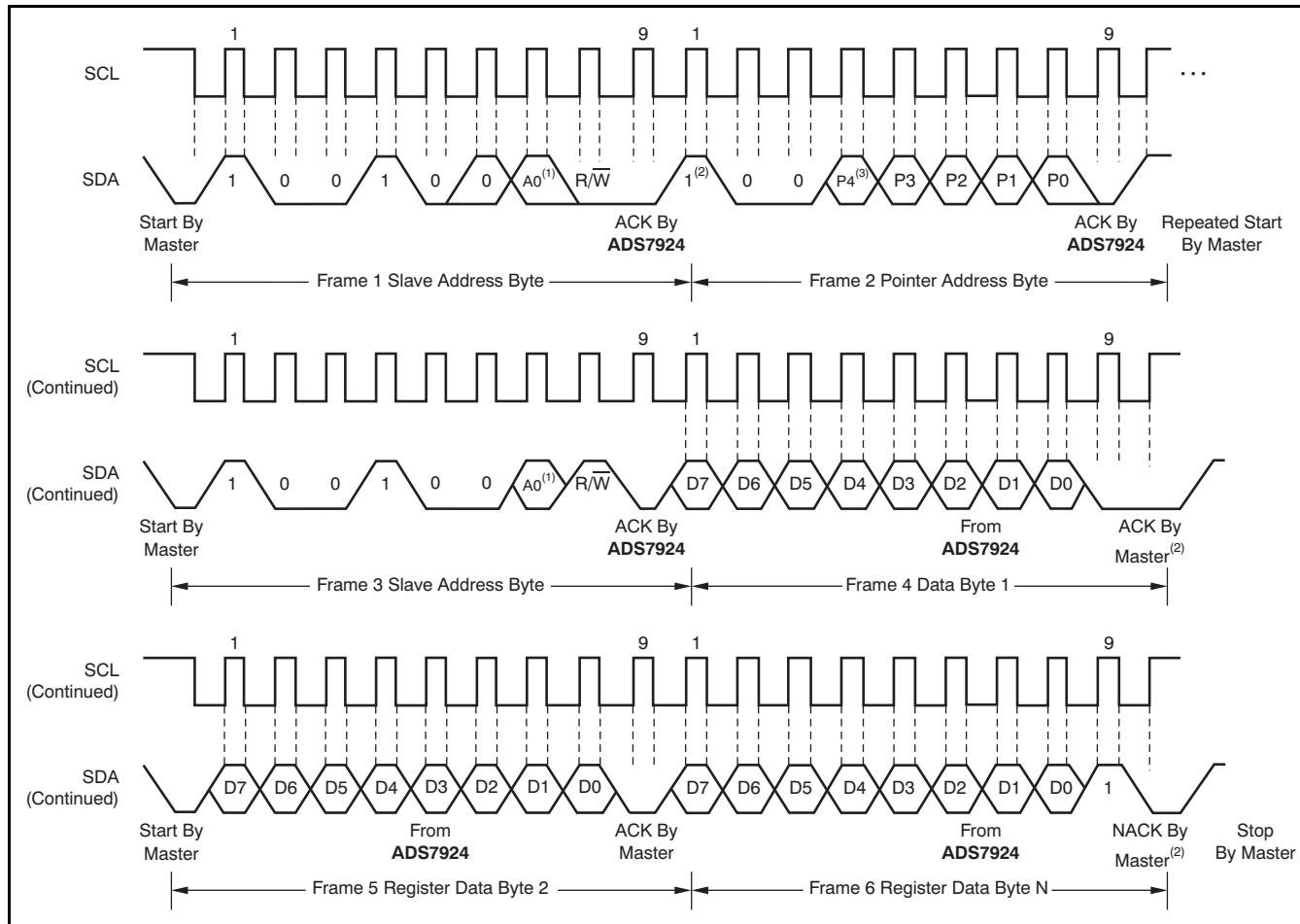

- (1) The value of A0 is determined by the A0 pin.
- (2) When INC is set to '1', the address pointer automatically increments for multiple register reads.
- (3) Bits P[4:0] point to the register to be read.

**Figure 34. Reading Multiple Registers Timing Diagram**

## APPLICATION INFORMATION

### AVERAGE POWER CONSUMPTION

With its fast conversion time and programmable sleep time with near-zero power, the ADS7924 allows periodic monitoring of the inputs with a very low average power dissipation, especially as the monitoring interval increases. The average current required can be calculated as the weighed average of the currents consumed during the power-up, acquisition, converting, and sleep periods using [Equation 3](#).

$$I_{\text{AVERAGE}} = \frac{I_{\text{PU}}t_{\text{PU}} + I_{\text{ACQ}}t_{\text{ACQ}} + I_{\text{CONV}}t_{\text{CONV}} + I_{\text{SLEEP}}t_{\text{SLEEP}}}{t_{\text{CYCLE}}} \quad (3)$$

As an example, calculate the average current in the following configuration:

- Mode programmed to Auto-Scan with Sleep
- Power-up time ( $t_{\text{PU}}$ ) programmed to '0'
- Acquisition time ( $t_{\text{ACQ}}$ ) programmed to 6 $\mu\text{s}$
- Sleep time ( $t_{\text{SLEEP}}$ ) programmed to 2.5ms
- AVDD = 2.2V

Looking at [Figure 28](#), the cycle time is seen to equal  $t_{\text{CYCLE}} = 4t_{\text{PU}} + 4t_{\text{ACQ}} + 4t_{\text{CONV}} + 4t_{\text{SLEEP}} = 4(0) + 4(6\mu\text{s}) + 4(4\mu\text{s}) + 4(2.5\text{ms}) = 10.04\text{ms}$ .

[Table 6](#) lists the supply current for different supply voltages and operating conditions. Using the data for 2.2V with the calculated cycle time in [Equation 3](#) gives the following average current:

$$I_{\text{AVERAGE}} = \frac{0 + (270\mu\text{A})(4)(6\mu\text{s}) + (400\mu\text{A})(4)(4\mu\text{s}) + (1.25\mu\text{A})(4)(2.5\text{ms})}{10.04\text{ms}} = 2.5\mu\text{A} \quad (4)$$

**Table 6. Supply Current for Various Operating Conditions**

STATUS	AVDD			
	5V	3.3V	2.7V	2.2V
Idle	1 $\mu\text{A}$	1 $\mu\text{A}$	1 $\mu\text{A}$	1 $\mu\text{A}$
Awake	45 $\mu\text{A}$	25 $\mu\text{A}$	20 $\mu\text{A}$	15 $\mu\text{A}$
Acquiring	315 $\mu\text{A}$	285 $\mu\text{A}$	275 $\mu\text{A}$	270 $\mu\text{A}$
Converting	730 $\mu\text{A}$	520 $\mu\text{A}$	450 $\mu\text{A}$	400 $\mu\text{A}$
Sleeping	3 $\mu\text{A}$	2 $\mu\text{A}$	1.5 $\mu\text{A}$	1.25 $\mu\text{A}$

Note the acquisition, conversion, and sleep times are multiplied by 4 because these are repeated four times in one cycle when in auto-scan with sleep mode.

Average power dissipation for the above configuration where all four inputs are monitored every 10ms is  $(2.2\text{V})(2.5\mu\text{A}) = 5.5\mu\text{W}$ .

[Figure 3](#) and [Figure 4](#) plot [Equation 3](#) to help illustrate the relationship between cycle time and average power dissipation.

## BASIC CONNECTIONS

The ADS7924 provides a break-out point in the signal path between the multiplexer output and the ADC input for external signal conditioning, if desired. Typical uses include adding an op amp, such as the [TLV2780](#), along with an RC filter circuit.

### Using an Op Amp

Adding an op amp provides a high input impedance to the sensor source and buffers the capacitive ADC input from high-impedance sensor circuits, as shown in [Figure 35](#). Note that high-impedance input signals can be momentarily disrupted when coupled directly to a capacitive input like that of a sampling ADC. This disruption can create errors when sampling. The use of an op amp is recommended in these cases.

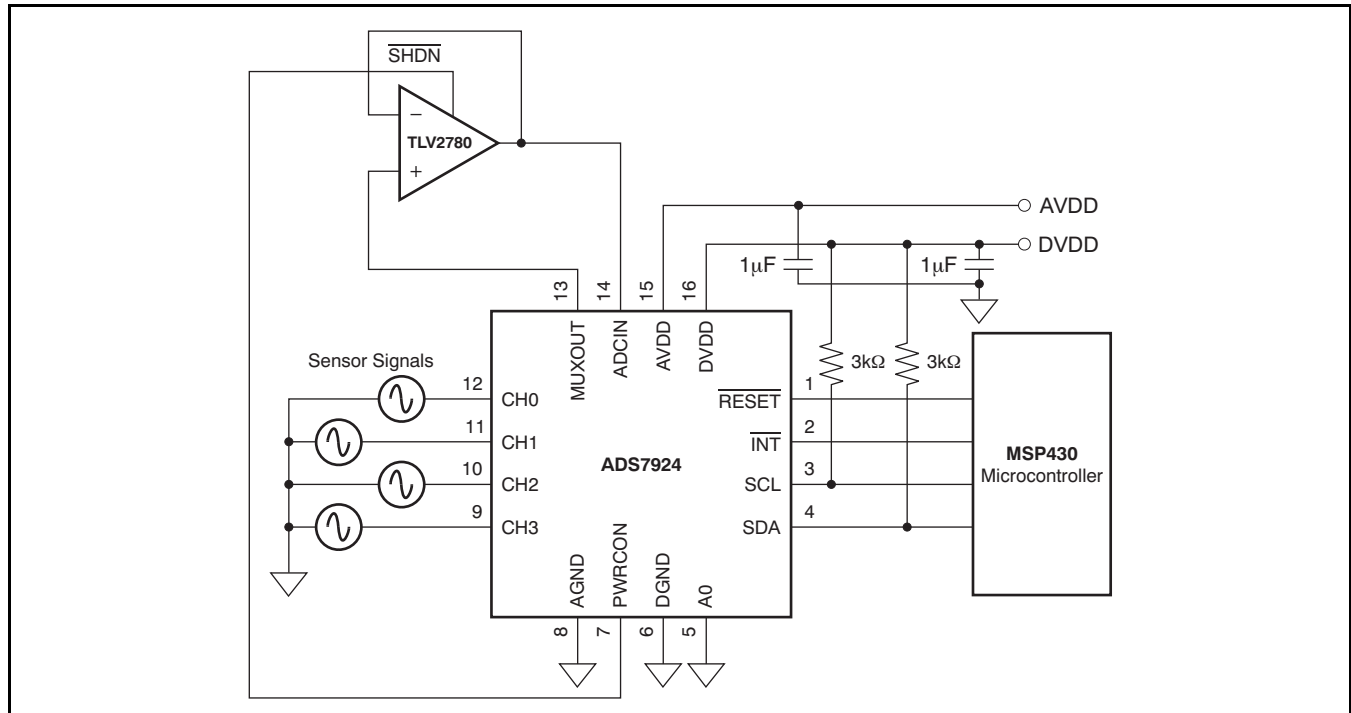

**Figure 35. Sensor Data Acquisition with TLV2780 Buffer Amplifier**

### Using an Op Amp and RC Filter

Placing an RC low-pass filter in the signal path allows for filtering out noise. The RC component values should allow for sufficient settling time when changing from channel to channel. The time required for a full-scale input signal to settle to within 1LSB of a 12-bit ADC is given by Equation 5:

$$\text{Settling Time} = R \times C \times \ln(2^{12}) \tag{5}$$

$R_X$  and  $C$  form a low-pass filter for removing sensor and noise from other sources at the op amp input pin. The low-pass bandwidth is given by Equation 6:

$$f_{-3dB} = 1/(2\pi RC) \tag{6}$$

The  $f_{-3dB}$  should be chosen such that the signals of interest are within half of the programmable sampling frequency. The noise bandwidth is given by Equation 7:

$$f_{NB} = 1/(4RC) \tag{7}$$

This term should be set to reduce noise bandwidth but still allow for enough settling time. Note that the ADS7924 has internal registers ACQCONFIG (address = 14h), PWRCONF (address = 15h), and SLPCONFIG (address = 13h) that can be programmed to slow down the channel-to-channel power up, acquisition, and sleep periods if needed to allow for a longer settling time requirement.

In Figure 36,  $R$  is the sum of the sensor output impedance  $R_{SENSOR}$ , the internal MUX resistance  $R_{MUX}$  (approximately  $60\Omega$ ), and external resistor  $R_X$ . The primary benefit of having the filter at the input of the op amp is that the amplifier does not have to drive the filter, which can cause instability with large capacitor values that may be needed in order to filter noise to low levels.

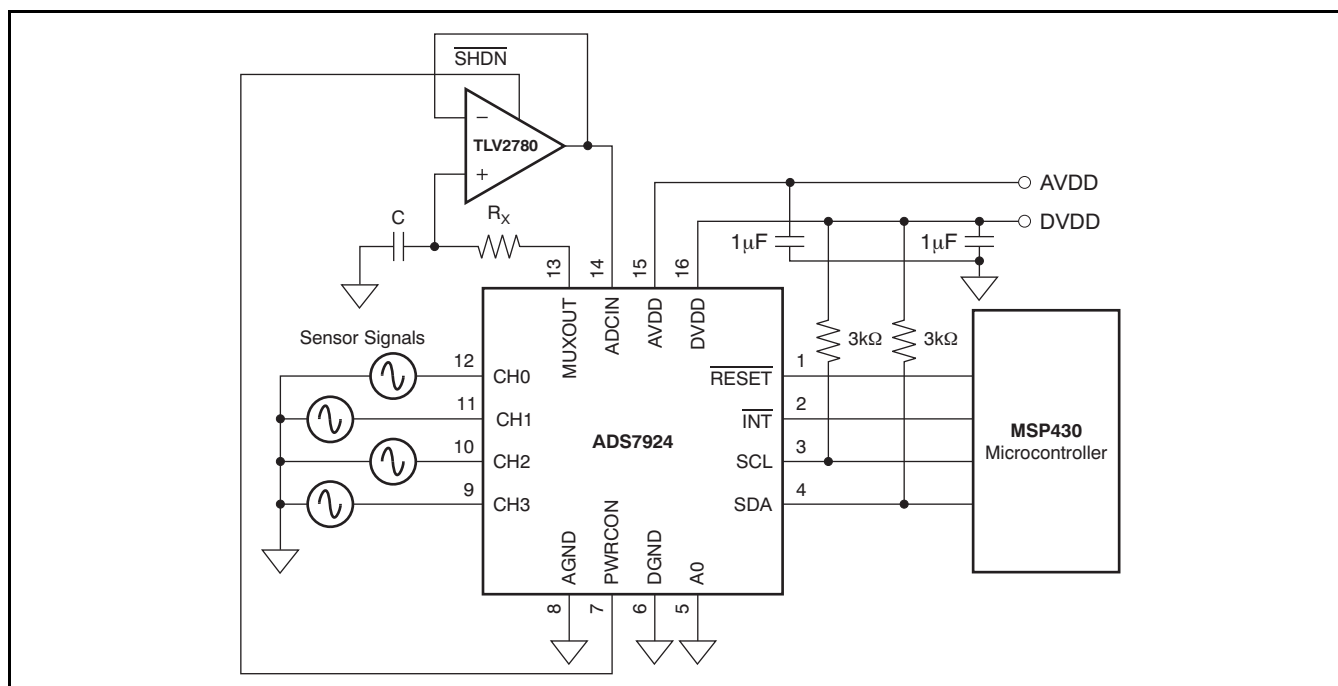

NOTE:  $f_{-3dB}$  BW = 159kHz,  $R = 1k\Omega$ , and  $C = 1nF$  where  $R = R_{MUX} + R_{SENSOR} + R_X$ .

**Figure 36. Sensor Data Acquisition with Filter and TLV2780 Buffer Amplifier**

### Op Amp Power-Up Time

The TLV2780 typically powers up from a shutdown state in 800ns. This period is well within the ADS7924 minimum acquisition time of 6μs. Setting the PWRCONFIG register (address = 15h) allows for more time if another op amp with a shutdown feature is used.

### Using an RC Filter

For applications where low output impedance signals are provided for the ADS7924 inputs, a simple RC filter may suffice, as shown in Figure 37.

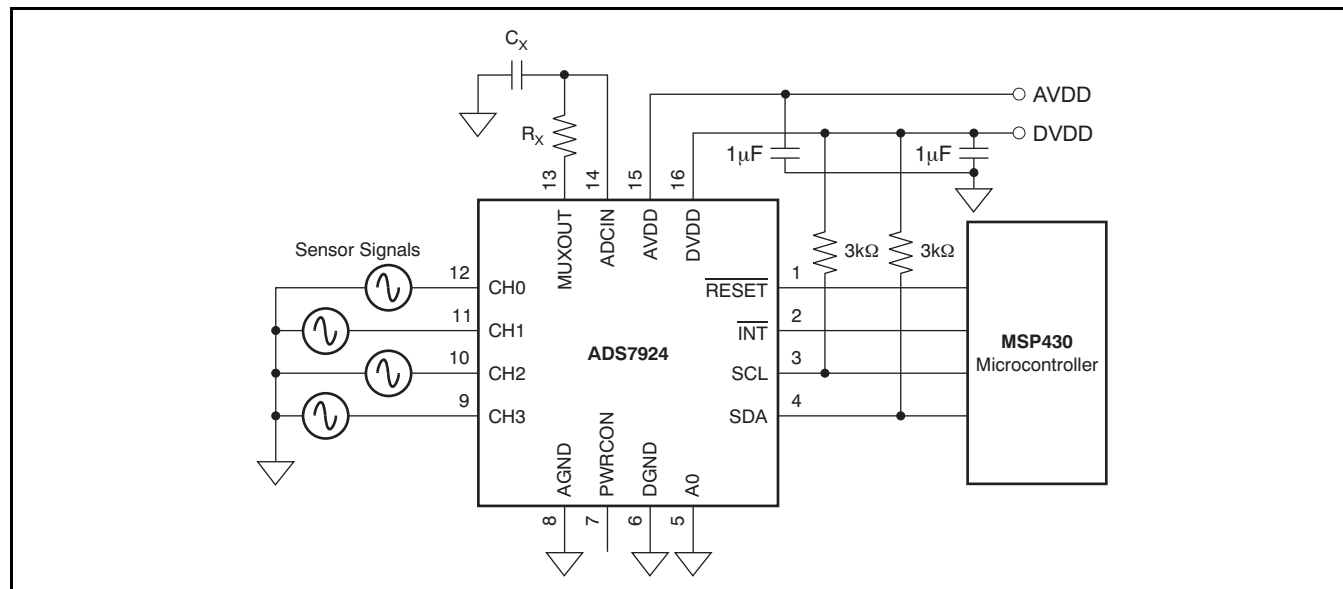

NOTE:  $f_{-3dB}$  BW = 159kHz,  $R = 1k\Omega$ , and  $C = 1nF$  where  $R = R_{MUX} + R_{SENSOR} + R_X$ ,  $C = C_X + C_{ADCIN}$ ,  $R_{MUX}$  is approximately 60Ω, and  $C_{ADCIN}$  is approximately 15pF.

**Figure 37. Sensor Data Acquisition with Filter Only**

$C_X$  should be greater than 200pF, if possible. When coupled directly to the ADC input, using a capacitor with this value allows for faster settling when scanning between channels.



### Driving an RC Filter and the ADCIN Pin With An Op Amp

A filter can be placed at the output of the op amp, as shown in Figure 39. Care must be taken to ensure that the op amp is capable of driving the RC filter circuit without the op amp becoming unstable. One of the benefits of this circuit is that the op amp noise is filtered along with sensor and other system noise right at the ADC input pin.

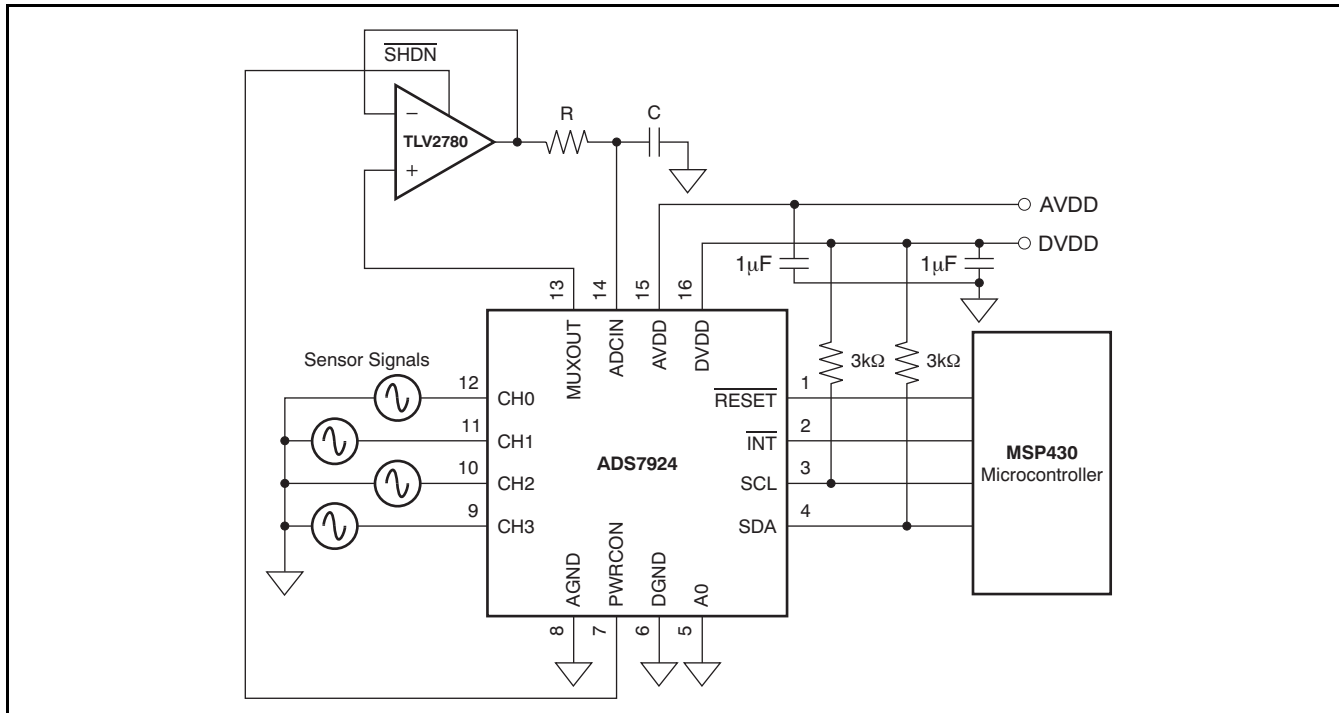

NOTE: C = 200pF, R = 1kΩ, and the capacitance at the ADCIN pin is approximately 15pF.

**Figure 39. Sensor Data Acquisition with an Op Amp Driving an RC Filter**

**PACKAGING INFORMATION**

Orderable Device	Status <sup>(1)</sup>	Package Type	Package Drawing	Pins	Package Qty	Eco Plan <sup>(2)</sup>	Lead/Ball Finish	MSL Peak Temp <sup>(3)</sup>
ADS7924IRTER	ACTIVE	WQFN	RTE	16	3000	Green (RoHS & no Sb/Br)	CU NIPDAU	Level-2-260C-1 YEAR
ADS7924IRTET	ACTIVE	WQFN	RTE	16	250	Green (RoHS & no Sb/Br)	CU NIPDAU	Level-2-260C-1 YEAR

<sup>(1)</sup> The marketing status values are defined as follows:

**ACTIVE:** Product device recommended for new designs.

**LIFEBUY:** TI has announced that the device will be discontinued, and a lifetime-buy period is in effect.

**NRND:** Not recommended for new designs. Device is in production to support existing customers, but TI does not recommend using this part in a new design.

**PREVIEW:** Device has been announced but is not in production. Samples may or may not be available.

**OBsolete:** TI has discontinued the production of the device.

<sup>(2)</sup> Eco Plan - The planned eco-friendly classification: Pb-Free (RoHS), Pb-Free (RoHS Exempt), or Green (RoHS & no Sb/Br) - please check <http://www.ti.com/productcontent> for the latest availability information and additional product content details.

**TBD:** The Pb-Free/Green conversion plan has not been defined.

**Pb-Free (RoHS):** TI's terms "Lead-Free" or "Pb-Free" mean semiconductor products that are compatible with the current RoHS requirements for all 6 substances, including the requirement that lead not exceed 0.1% by weight in homogeneous materials. Where designed to be soldered at high temperatures, TI Pb-Free products are suitable for use in specified lead-free processes.

**Pb-Free (RoHS Exempt):** This component has a RoHS exemption for either 1) lead-based flip-chip solder bumps used between the die and package, or 2) lead-based die adhesive used between the die and leadframe. The component is otherwise considered Pb-Free (RoHS compatible) as defined above.

**Green (RoHS & no Sb/Br):** TI defines "Green" to mean Pb-Free (RoHS compatible), and free of Bromine (Br) and Antimony (Sb) based flame retardants (Br or Sb do not exceed 0.1% by weight in homogeneous material)

<sup>(3)</sup> MSL, Peak Temp. -- The Moisture Sensitivity Level rating according to the JEDEC industry standard classifications, and peak solder temperature.

**Important Information and Disclaimer:** The information provided on this page represents TI's knowledge and belief as of the date that it is provided. TI bases its knowledge and belief on information provided by third parties, and makes no representation or warranty as to the accuracy of such information. Efforts are underway to better integrate information from third parties. TI has taken and continues to take reasonable steps to provide representative and accurate information but may not have conducted destructive testing or chemical analysis on incoming materials and chemicals. TI and TI suppliers consider certain information to be proprietary, and thus CAS numbers and other limited information may not be available for release.

In no event shall TI's liability arising out of such information exceed the total purchase price of the TI part(s) at issue in this document sold by TI to Customer on an annual basis.

RTE (S-PQFP-N16)

PLASTIC QUAD FLATPACK

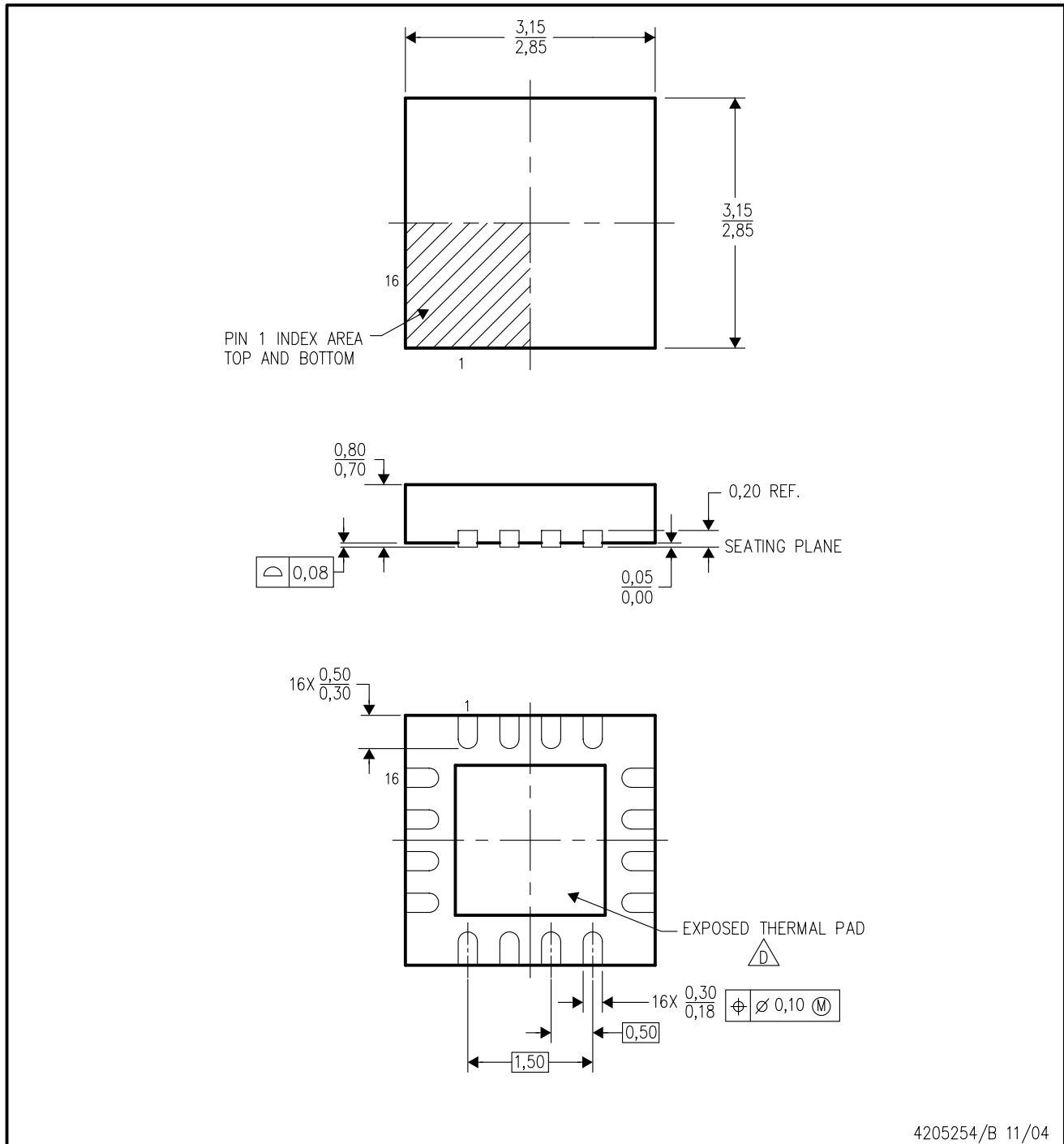

- NOTES:
- A. All linear dimensions are in millimeters. Dimensioning and tolerancing per ASME Y14.5M-1994.
  - B. This drawing is subject to change without notice.
  - C. Quad Flatpack, No-leads (QFN) package configuration.
  -  The package thermal pad must be soldered to the board for thermal and mechanical performance. See the Product Data Sheet for details regarding the exposed thermal pad dimensions.
  - E. Falls within JEDEC MO-220.

## THERMAL PAD MECHANICAL DATA

RTE (S-PWQFN-N16)

PLASTIC QUAD FLATPACK NO-LEAD

### THERMAL INFORMATION

This package incorporates an exposed thermal pad that is designed to be attached directly to an external heatsink. The thermal pad must be soldered directly to the printed circuit board (PCB). After soldering, the PCB can be used as a heatsink. In addition, through the use of thermal vias, the thermal pad can be attached directly to the appropriate copper plane shown in the electrical schematic for the device, or alternatively, can be attached to a special heatsink structure designed into the PCB. This design optimizes the heat transfer from the integrated circuit (IC).

For information on the Quad Flatpack No-Lead (QFN) package and its advantages, refer to Application Report, QFN/SON PCB Attachment, Texas Instruments Literature No. SLUA271. This document is available at [www.ti.com](http://www.ti.com).

The exposed thermal pad dimensions for this package are shown in the following illustration.

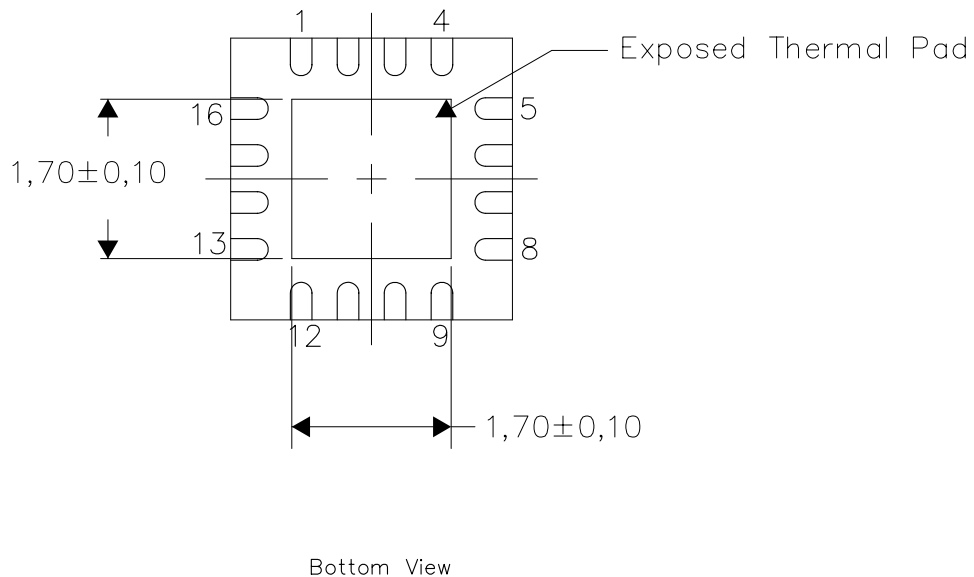

NOTE: All linear dimensions are in millimeters

Exposed Thermal Pad Dimensions

4206446-3/F 07/10

RTE (S-PWQFN-N16)

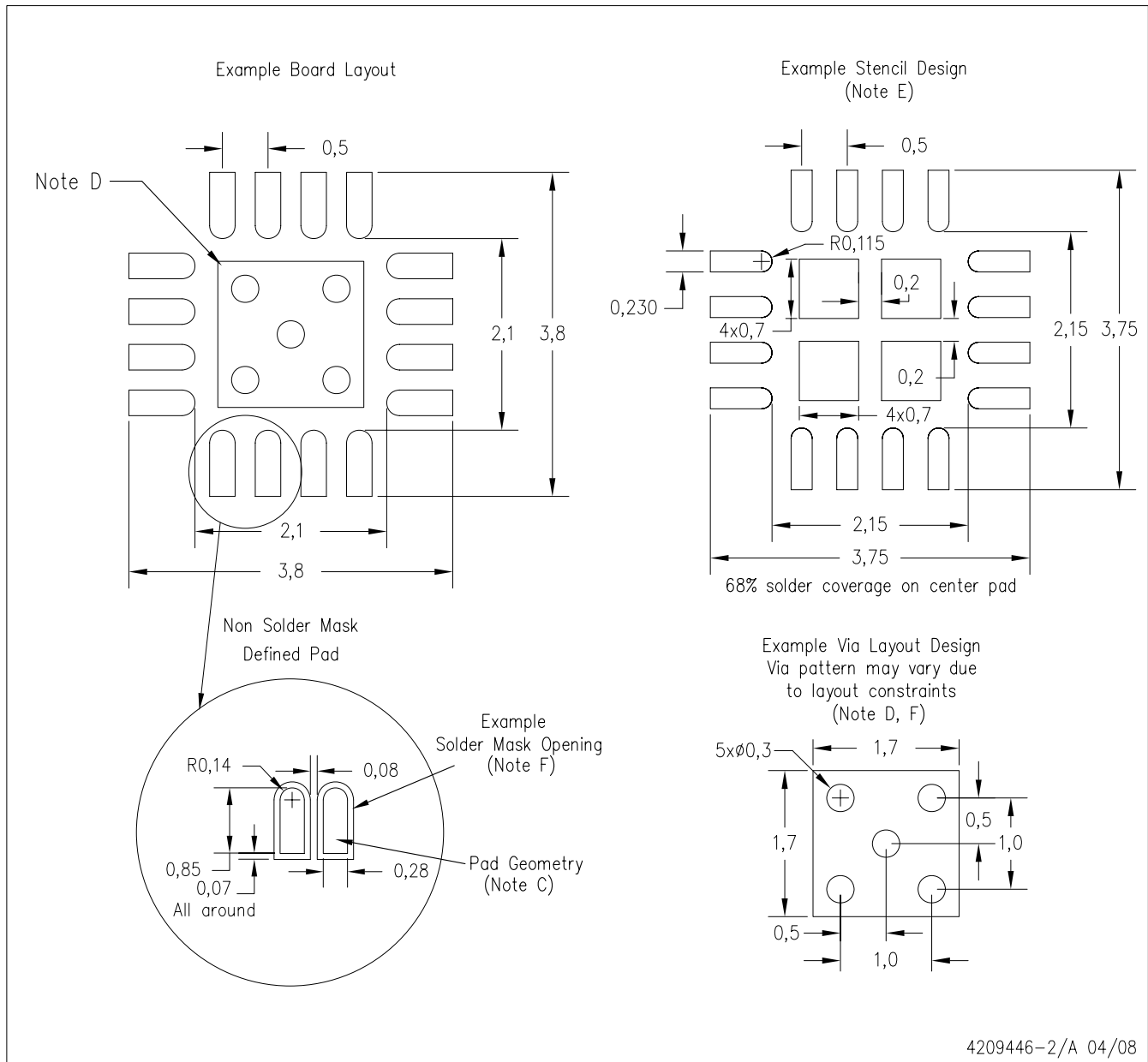

- NOTES:
- A. All linear dimensions are in millimeters.
  - B. This drawing is subject to change without notice.
  - C. Publication IPC-7351 is recommended for alternate designs.
  - D. This package is designed to be soldered to a thermal pad on the board. Refer to Application Note, Quad Flat-Pack Packages, Texas Instruments Literature No. SCBA017, SLUA271, and also the Product Data Sheets for specific thermal information, via requirements, and recommended board layout. These documents are available at [www.ti.com](http://www.ti.com) <<http://www.ti.com>>.
  - E. Laser cutting apertures with trapezoidal walls and also rounding corners will offer better paste release. Customers should contact their board assembly site for stencil design recommendations. Refer to IPC 7525 for stencil design considerations.
  - F. Customers should contact their board fabrication site for minimum solder mask web tolerances between signal pads.

## IMPORTANT NOTICE

Texas Instruments Incorporated and its subsidiaries (TI) reserve the right to make corrections, modifications, enhancements, improvements, and other changes to its products and services at any time and to discontinue any product or service without notice. Customers should obtain the latest relevant information before placing orders and should verify that such information is current and complete. All products are sold subject to TI's terms and conditions of sale supplied at the time of order acknowledgment.

TI warrants performance of its hardware products to the specifications applicable at the time of sale in accordance with TI's standard warranty. Testing and other quality control techniques are used to the extent TI deems necessary to support this warranty. Except where mandated by government requirements, testing of all parameters of each product is not necessarily performed.

TI assumes no liability for applications assistance or customer product design. Customers are responsible for their products and applications using TI components. To minimize the risks associated with customer products and applications, customers should provide adequate design and operating safeguards.

TI does not warrant or represent that any license, either express or implied, is granted under any TI patent right, copyright, mask work right, or other TI intellectual property right relating to any combination, machine, or process in which TI products or services are used. Information published by TI regarding third-party products or services does not constitute a license from TI to use such products or services or a warranty or endorsement thereof. Use of such information may require a license from a third party under the patents or other intellectual property of the third party, or a license from TI under the patents or other intellectual property of TI.

Reproduction of TI information in TI data books or data sheets is permissible only if reproduction is without alteration and is accompanied by all associated warranties, conditions, limitations, and notices. Reproduction of this information with alteration is an unfair and deceptive business practice. TI is not responsible or liable for such altered documentation. Information of third parties may be subject to additional restrictions.

Resale of TI products or services with statements different from or beyond the parameters stated by TI for that product or service voids all express and any implied warranties for the associated TI product or service and is an unfair and deceptive business practice. TI is not responsible or liable for any such statements.

TI products are not authorized for use in safety-critical applications (such as life support) where a failure of the TI product would reasonably be expected to cause severe personal injury or death, unless officers of the parties have executed an agreement specifically governing such use. Buyers represent that they have all necessary expertise in the safety and regulatory ramifications of their applications, and acknowledge and agree that they are solely responsible for all legal, regulatory and safety-related requirements concerning their products and any use of TI products in such safety-critical applications, notwithstanding any applications-related information or support that may be provided by TI. Further, Buyers must fully indemnify TI and its representatives against any damages arising out of the use of TI products in such safety-critical applications.

TI products are neither designed nor intended for use in military/aerospace applications or environments unless the TI products are specifically designated by TI as military-grade or "enhanced plastic." Only products designated by TI as military-grade meet military specifications. Buyers acknowledge and agree that any such use of TI products which TI has not designated as military-grade is solely at the Buyer's risk, and that they are solely responsible for compliance with all legal and regulatory requirements in connection with such use.

TI products are neither designed nor intended for use in automotive applications or environments unless the specific TI products are designated by TI as compliant with ISO/TS 16949 requirements. Buyers acknowledge and agree that, if they use any non-designated products in automotive applications, TI will not be responsible for any failure to meet such requirements.

Following are URLs where you can obtain information on other Texas Instruments products and application solutions:

<b>Products</b>		<b>Applications</b>	
Amplifiers	<a href="http://amplifier.ti.com">amplifier.ti.com</a>	Audio	<a href="http://www.ti.com/audio">www.ti.com/audio</a>
Data Converters	<a href="http://dataconverter.ti.com">dataconverter.ti.com</a>	Automotive	<a href="http://www.ti.com/automotive">www.ti.com/automotive</a>
DLP® Products	<a href="http://www.dlp.com">www.dlp.com</a>	Communications and Telecom	<a href="http://www.ti.com/communications">www.ti.com/communications</a>
DSP	<a href="http://dsp.ti.com">dsp.ti.com</a>	Computers and Peripherals	<a href="http://www.ti.com/computers">www.ti.com/computers</a>
Clocks and Timers	<a href="http://www.ti.com/clocks">www.ti.com/clocks</a>	Consumer Electronics	<a href="http://www.ti.com/consumer-apps">www.ti.com/consumer-apps</a>
Interface	<a href="http://interface.ti.com">interface.ti.com</a>	Energy	<a href="http://www.ti.com/energy">www.ti.com/energy</a>
Logic	<a href="http://logic.ti.com">logic.ti.com</a>	Industrial	<a href="http://www.ti.com/industrial">www.ti.com/industrial</a>
Power Mgmt	<a href="http://power.ti.com">power.ti.com</a>	Medical	<a href="http://www.ti.com/medical">www.ti.com/medical</a>
Microcontrollers	<a href="http://microcontroller.ti.com">microcontroller.ti.com</a>	Security	<a href="http://www.ti.com/security">www.ti.com/security</a>
RFID	<a href="http://www.ti-rfid.com">www.ti-rfid.com</a>	Space, Avionics & Defense	<a href="http://www.ti.com/space-avionics-defense">www.ti.com/space-avionics-defense</a>
RF/IF and ZigBee® Solutions	<a href="http://www.ti.com/lprf">www.ti.com/lprf</a>	Video and Imaging	<a href="http://www.ti.com/video">www.ti.com/video</a>
		Wireless	<a href="http://www.ti.com/wireless-apps">www.ti.com/wireless-apps</a>

Mailing Address: Texas Instruments, Post Office Box 655303, Dallas, Texas 75265  
Copyright © 2010, Texas Instruments Incorporated