

LM747QML

LM747QML Dual Operational Amplifier



Literature Number: SNOSAR6

LM747QML

Dual Operational Amplifier

General Description

The LM747 is a general purpose dual operational amplifier. The two amplifiers share a common bias network and power supply leads. Otherwise, their operation is completely independent.

Additional features of the LM747 are: no latch-up when input common mode range is exceeded, freedom from oscillations, and package flexibility.

Features

- No frequency compensation required
- Short-circuit protection
- Wide common-mode and differential voltage ranges
- Low power consumption
- No latch-up

Ordering Information

NS Part Number	SMD Part Number	NS Package Number	Package Description
LM747H/883		H10C	10LD TO-100 Metal Can
LM747J/883		J14A	14LD Ceramic Dip

Connection Diagrams

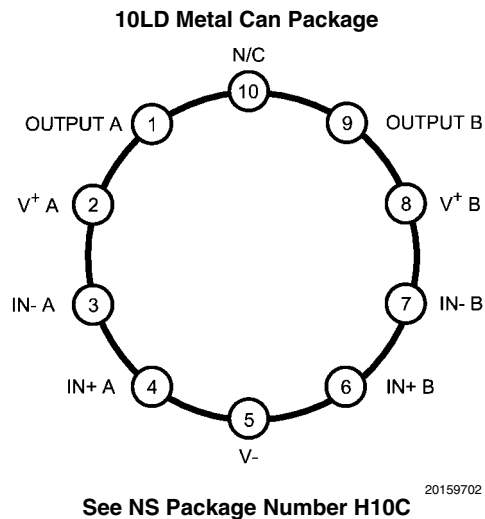
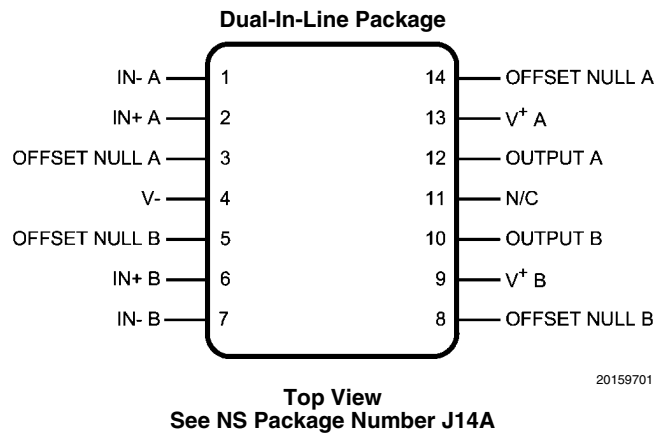

Absolute Maximum Ratings *(Note 1)*

Supply voltage	±22V
Power Dissipation <i>(Note 2)</i>	800mW
Differential Input Voltage	±30V
Input Voltage <i>(Note 3)</i>	±15V
Output Short-Circuit Duration	Indefinite
Maximum Junction Temperature (T_{Jmax})	150°C
Operating Temperature Range	$-55^{\circ}\text{C} \leq T_A \leq +125^{\circ}\text{C}$
Storage Temperature Range	$-65^{\circ}\text{C} \leq T_A \leq +150^{\circ}\text{C}$
Lead Temperature (Soldering, 10 seconds)	+300°C

Quality Conformance Inspection

Mil-Std-883, Method 5005 - Group A

Subgroup	Description	Temp (°C)
1	Static tests at	+25
2	Static tests at	+125
3	Static tests at	-55
4	Dynamic tests at	+25
5	Dynamic tests at	+125
6	Dynamic tests at	-55
7	Functional tests at	+25
8A	Functional tests at	+125
8B	Functional tests at	-55
9	Switching tests at	+25
10	Switching tests at	+125
11	Switching tests at	-55
12	Settling time at	+25
13	Settling time at	+125
14	Settling time at	-55

LM747 Electrical Characteristics

DC Parameters

The following conditions apply, unless otherwise specified. $V_{CC} = \pm 15V$, $V_{CM} = 0V$

Symbol	Parameter	Conditions	Notes	Min	Max	Units	Sub-groups		
V_{IO}	Input Offset Voltage	$R_S = 50\Omega$, $V_{CM} = -12V$		-5.0	5.0	mV	1		
				-6.0	6.0	mV	2, 3		
		$R_S = 50\Omega$, $V_{CM} = 12V$		-5.0	5.0	mV	1		
				-6.0	6.0	mV	2, 3		
		$R_S = 50\Omega$		-5.0	5.0	mV	1		
				-6.0	6.0	mV	2, 3		
		$R_S = 50\Omega$, $V_{CC} = \pm 5V$		-5.0	5.0	mV	1		
				-6.0	6.0	mV	2, 3		
I_{IO}	Input Offset Current	$V_{CM} = -12V$		-200	200	nA	1		
				-500	500	nA	2, 3		
		$V_{CM} = 12V$		-200	200	nA	1		
				-500	500	nA	2, 3		
		$V_{CC} = \pm 5V$		-200	200	nA	1		
				-500	500	nA	2, 3		
		I_{IB}^+	Input Bias Current	$V_{CM} = -12V$		0.0	500	nA	1
						0.0	1500	nA	2, 3
$V_{CM} = 12V$				0.0	500	nA	1		
				0.0	1500	nA	2, 3		
$V_{CC} = \pm 5V$				0.0	500	nA	1		
				0.0	1500	nA	2, 3		
I_{IB}^-	Input Bias Current			$V_{CM} = -12V$		0.0	500	nA	1
						0.0	1500	nA	2, 3
		$V_{CM} = 12V$		0.0	500	nA	1		
				0.0	1500	nA	2, 3		
		$V_{CC} = \pm 5V$		0.0	500	nA	1		
				0.0	1500	nA	2, 3		
		$V_{IO\ Adj}^+$	Input Offset Voltage Adjustment Range		(Note 7)	6.0		mV	1, 2, 3
		$V_{IO\ Adj}^-$	Input Offset Voltage Adjustment Range		(Note 7)		-6.0	mV	1, 2, 3
PSRR+	Power Supply Rejection Ratio	$R_S = 50\Omega$, $V_{CC} = \pm 15V$ to $\pm 5V$		77		dB	1, 2, 3		
PSRR-	Power Supply Rejection Ratio	$R_S = 50\Omega$, $V_{CC} = \pm 15V$ to $\pm 5V$		77		dB	1, 2, 3		
CMRR	Common Mode Rejection Ratio	$R_S = 50\Omega$, $V_{CM} = \pm 12V$		70		dB	1, 2, 3		
I_{OS}^+	Output Short Circuit Current			-45	-9.0	mA	1, 2		
				-50	-9.0	mA	3		
I_{OS}^-	Output Short Circuit Current			9.0	45	mA	1, 2		
				9.0	50	mA	3		

Symbol	Parameter	Conditions	Notes	Min	Max	Units	Sub-groups
I _{CC}	Supply Current				5.6	mA	1
					5.0	mA	2
					6.6	mA	3
V _{OP+}	Output Voltage Swing	R _L = 10KΩ		12		V	1, 2, 3
		R _L = 2KΩ		10		V	1, 2, 3
		V _{CC} = ±20V, R _L = 10KΩ		16		V	1, 2, 3
		V _{CC} = ±20V, R _L = 2KΩ		15		V	1, 2, 3
V _{OP-}	Output Voltage Swing	R _L = 10KΩ			-12	V	1, 2, 3
		R _L = 2KΩ			-10	V	1, 2, 3
		V _{CC} = ±20V, R _L = 10KΩ			-16	V	1, 2, 3
		V _{CC} = ±20V, R _L = 2KΩ			-15	V	1, 2, 3
A _{VS+}	Open Loop Voltage Gain	V _O = 0 to +10V, R _L = 2K	(Note 6)	50		V/mV	1
				25		V/mV	2, 3
A _{VS-}	Open Loop Voltage Gain	V _O = 0 to -10V, R _L = 2K	(Note 6)	50		V/mV	1
				25		V/mV	2, 3
V _I	Input Voltage Range		(Note 4)	12	-12	V	1, 2, 3
V _{OP}	Output Voltage Swing	V _{CC} = ±5V	(Note 5)	2	-2	V	1, 2, 3

AC Parameters

The following conditions apply, unless otherwise specified.

AC: V_{CC} = ±15V, V_{CM} = 0V

Symbol	Parameter	Conditions	Notes	Min	Max	Units	Sub-groups
SR ⁺	Slew Rate	A _V = 1, V _I = -5V to +5V		0.2		V/μS	9
SR ⁻	Slew Rate	A _V = 1, V _I = +5V to -5V		0.2		V/μS	9
GBW	Gain Bandwidth	V _I = 50mV, f = 20KHz, R _L = 2KΩ		0.25		Mhz	9

Note 1: Absolute Maximum Ratings indicate limits beyond which damage to the device may occur. Operating Ratings indicate conditions for which the device is functional, but do not guarantee specific performance limits. For guaranteed specifications and test conditions, see the Electrical Characteristics. The guaranteed specifications apply only for the test conditions listed. Some performance characteristics may degrade when the device is not operated under the listed test conditions.

Note 2: The maximum power dissipation must be derated at elevated temperatures and is dictated by T_{Jmax} (maximum junction temperature), θ_{JA} (package junction to ambient thermal resistance), and T_A (ambient temperature). The maximum allowable power dissipation at any temperature is P_{Dmax} = (T_{Jmax} - T_A) / θ_{JA} or the number given in the Absolute Maximum Ratings, whichever is lower.

Note 3: For supply voltages less than ±15V, the absolute maximum input voltage is equal to the supply voltage.

Note 4: Parameter tested go-no-go only, guaranteed by CMRR test.

Note 5: Guaranteed parameter, not tested.

Note 6: Datalog reading in K = V/mV

Note 7: Tested for CERDIPs only.

Revision History

Released	Revision	Section	Changes
12/16/2010	A	New Release, Corporate format	1 MDS data sheet converted into one Corp. data sheet format. The drift table was eliminated from the 883 section since it did not apply; MNLM747-X Rev 0BL will be archived.

Physical Dimensions inches (millimeters) unless otherwise noted

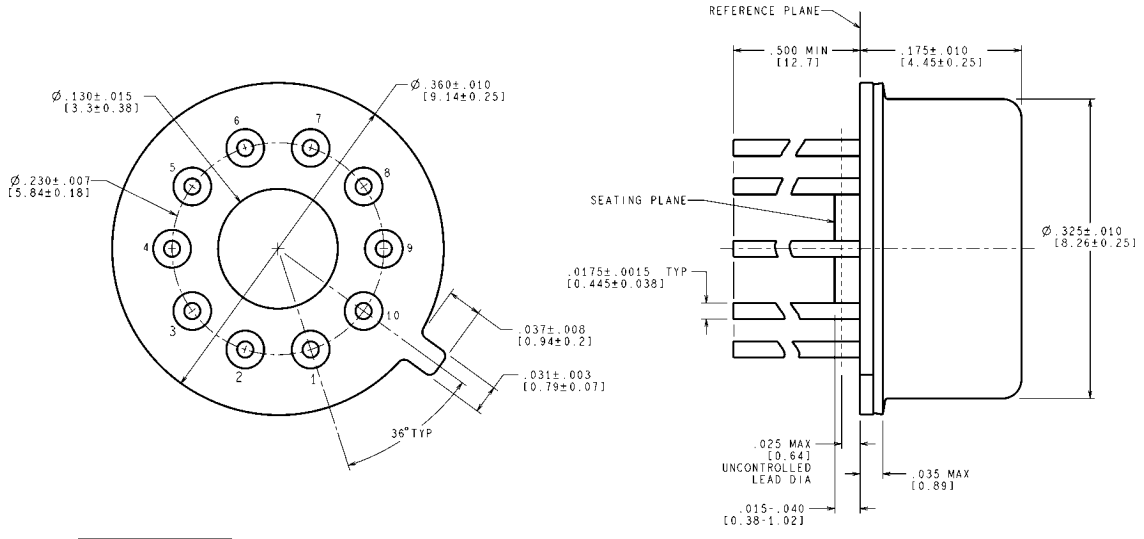

MIL-PRF-38535
CONFIGURATION CONTROL

CONTROLLING DIMENSION IS INCH
VALUES IN [] ARE IN MILLIMETERS

H10C (Rev G)

**10 Pin Metal Can Package (H)
NS Package Number H10C**

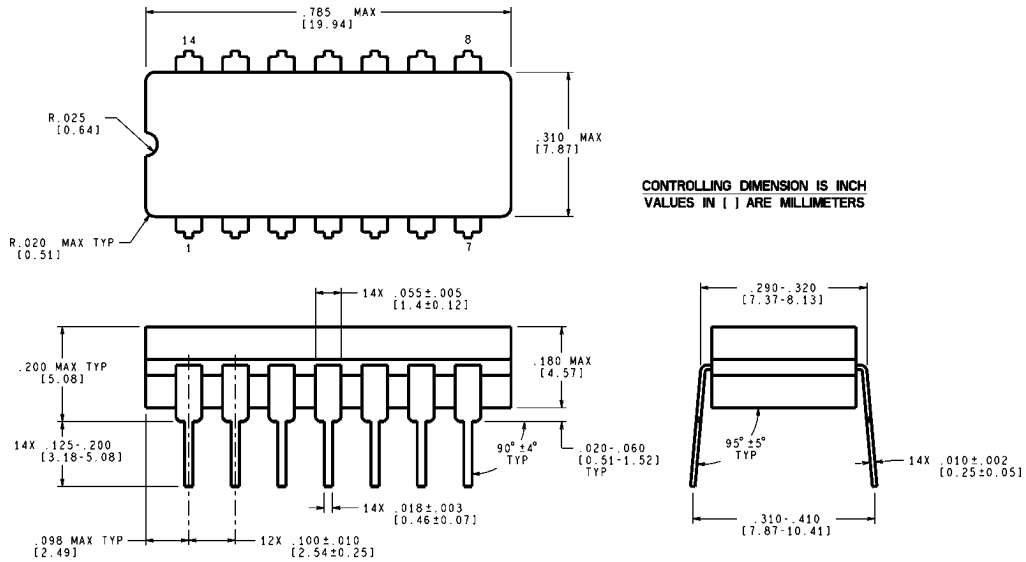

CONTROLLING DIMENSION IS INCH
VALUES IN [] ARE MILLIMETERS

J14A (Rev J)

**14 Pin Cerdip Package (J)
NS Package Number J14A**

Notes

LM747QML

Notes

For more National Semiconductor product information and proven design tools, visit the following Web sites at:
www.national.com

Products		Design Support	
Amplifiers	www.national.com/amplifiers	WEBENCH® Tools	www.national.com/webench
Audio	www.national.com/audio	App Notes	www.national.com/appnotes
Clock and Timing	www.national.com/timing	Reference Designs	www.national.com/refdesigns
Data Converters	www.national.com/adc	Samples	www.national.com/samples
Interface	www.national.com/interface	Eval Boards	www.national.com/evalboards
LVDS	www.national.com/lvds	Packaging	www.national.com/packaging
Power Management	www.national.com/power	Green Compliance	www.national.com/quality/green
Switching Regulators	www.national.com/switchers	Distributors	www.national.com/contacts
LDOs	www.national.com/ldo	Quality and Reliability	www.national.com/quality
LED Lighting	www.national.com/led	Feedback/Support	www.national.com/feedback
Voltage References	www.national.com/vref	Design Made Easy	www.national.com/easy
PowerWise® Solutions	www.national.com/powerwise	Applications & Markets	www.national.com/solutions
Serial Digital Interface (SDI)	www.national.com/sdi	Mil/Aero	www.national.com/milaero
Temperature Sensors	www.national.com/tempensors	SolarMagic™	www.national.com/solarmagic
PLL/VCO	www.national.com/wireless	PowerWise® Design University	www.national.com/training

THE CONTENTS OF THIS DOCUMENT ARE PROVIDED IN CONNECTION WITH NATIONAL SEMICONDUCTOR CORPORATION ("NATIONAL") PRODUCTS. NATIONAL MAKES NO REPRESENTATIONS OR WARRANTIES WITH RESPECT TO THE ACCURACY OR COMPLETENESS OF THE CONTENTS OF THIS PUBLICATION AND RESERVES THE RIGHT TO MAKE CHANGES TO SPECIFICATIONS AND PRODUCT DESCRIPTIONS AT ANY TIME WITHOUT NOTICE. NO LICENSE, WHETHER EXPRESS, IMPLIED, ARISING BY ESTOPPEL OR OTHERWISE, TO ANY INTELLECTUAL PROPERTY RIGHTS IS GRANTED BY THIS DOCUMENT.

TESTING AND OTHER QUALITY CONTROLS ARE USED TO THE EXTENT NATIONAL DEEMS NECESSARY TO SUPPORT NATIONAL'S PRODUCT WARRANTY. EXCEPT WHERE MANDATED BY GOVERNMENT REQUIREMENTS, TESTING OF ALL PARAMETERS OF EACH PRODUCT IS NOT NECESSARILY PERFORMED. NATIONAL ASSUMES NO LIABILITY FOR APPLICATIONS ASSISTANCE OR BUYER PRODUCT DESIGN. BUYERS ARE RESPONSIBLE FOR THEIR PRODUCTS AND APPLICATIONS USING NATIONAL COMPONENTS. PRIOR TO USING OR DISTRIBUTING ANY PRODUCTS THAT INCLUDE NATIONAL COMPONENTS, BUYERS SHOULD PROVIDE ADEQUATE DESIGN, TESTING AND OPERATING SAFEGUARDS.

EXCEPT AS PROVIDED IN NATIONAL'S TERMS AND CONDITIONS OF SALE FOR SUCH PRODUCTS, NATIONAL ASSUMES NO LIABILITY WHATSOEVER, AND NATIONAL DISCLAIMS ANY EXPRESS OR IMPLIED WARRANTY RELATING TO THE SALE AND/OR USE OF NATIONAL PRODUCTS INCLUDING LIABILITY OR WARRANTIES RELATING TO FITNESS FOR A PARTICULAR PURPOSE, MERCHANTABILITY, OR INFRINGEMENT OF ANY PATENT, COPYRIGHT OR OTHER INTELLECTUAL PROPERTY RIGHT.

LIFE SUPPORT POLICY

NATIONAL'S PRODUCTS ARE NOT AUTHORIZED FOR USE AS CRITICAL COMPONENTS IN LIFE SUPPORT DEVICES OR SYSTEMS WITHOUT THE EXPRESS PRIOR WRITTEN APPROVAL OF THE CHIEF EXECUTIVE OFFICER AND GENERAL COUNSEL OF NATIONAL SEMICONDUCTOR CORPORATION. As used herein:

Life support devices or systems are devices which (a) are intended for surgical implant into the body, or (b) support or sustain life and whose failure to perform when properly used in accordance with instructions for use provided in the labeling can be reasonably expected to result in a significant injury to the user. A critical component is any component in a life support device or system whose failure to perform can be reasonably expected to cause the failure of the life support device or system or to affect its safety or effectiveness.

National Semiconductor and the National Semiconductor logo are registered trademarks of National Semiconductor Corporation. All other brand or product names may be trademarks or registered trademarks of their respective holders.

Copyright© 2010 National Semiconductor Corporation

For the most current product information visit us at www.national.com



**National Semiconductor
Americas Technical
Support Center**
Email: support@nsc.com
Tel: 1-800-272-9959

**National Semiconductor Europe
Technical Support Center**
Email: europe.support@nsc.com

**National Semiconductor Asia
Pacific Technical Support Center**
Email: ap.support@nsc.com

**National Semiconductor Japan
Technical Support Center**
Email: jpn.feedback@nsc.com

IMPORTANT NOTICE

Texas Instruments Incorporated and its subsidiaries (TI) reserve the right to make corrections, modifications, enhancements, improvements, and other changes to its products and services at any time and to discontinue any product or service without notice. Customers should obtain the latest relevant information before placing orders and should verify that such information is current and complete. All products are sold subject to TI's terms and conditions of sale supplied at the time of order acknowledgment.

TI warrants performance of its hardware products to the specifications applicable at the time of sale in accordance with TI's standard warranty. Testing and other quality control techniques are used to the extent TI deems necessary to support this warranty. Except where mandated by government requirements, testing of all parameters of each product is not necessarily performed.

TI assumes no liability for applications assistance or customer product design. Customers are responsible for their products and applications using TI components. To minimize the risks associated with customer products and applications, customers should provide adequate design and operating safeguards.

TI does not warrant or represent that any license, either express or implied, is granted under any TI patent right, copyright, mask work right, or other TI intellectual property right relating to any combination, machine, or process in which TI products or services are used. Information published by TI regarding third-party products or services does not constitute a license from TI to use such products or services or a warranty or endorsement thereof. Use of such information may require a license from a third party under the patents or other intellectual property of the third party, or a license from TI under the patents or other intellectual property of TI.

Reproduction of TI information in TI data books or data sheets is permissible only if reproduction is without alteration and is accompanied by all associated warranties, conditions, limitations, and notices. Reproduction of this information with alteration is an unfair and deceptive business practice. TI is not responsible or liable for such altered documentation. Information of third parties may be subject to additional restrictions.

Resale of TI products or services with statements different from or beyond the parameters stated by TI for that product or service voids all express and any implied warranties for the associated TI product or service and is an unfair and deceptive business practice. TI is not responsible or liable for any such statements.

TI products are not authorized for use in safety-critical applications (such as life support) where a failure of the TI product would reasonably be expected to cause severe personal injury or death, unless officers of the parties have executed an agreement specifically governing such use. Buyers represent that they have all necessary expertise in the safety and regulatory ramifications of their applications, and acknowledge and agree that they are solely responsible for all legal, regulatory and safety-related requirements concerning their products and any use of TI products in such safety-critical applications, notwithstanding any applications-related information or support that may be provided by TI. Further, Buyers must fully indemnify TI and its representatives against any damages arising out of the use of TI products in such safety-critical applications.

TI products are neither designed nor intended for use in military/aerospace applications or environments unless the TI products are specifically designated by TI as military-grade or "enhanced plastic." Only products designated by TI as military-grade meet military specifications. Buyers acknowledge and agree that any such use of TI products which TI has not designated as military-grade is solely at the Buyer's risk, and that they are solely responsible for compliance with all legal and regulatory requirements in connection with such use.

TI products are neither designed nor intended for use in automotive applications or environments unless the specific TI products are designated by TI as compliant with ISO/TS 16949 requirements. Buyers acknowledge and agree that, if they use any non-designated products in automotive applications, TI will not be responsible for any failure to meet such requirements.

Following are URLs where you can obtain information on other Texas Instruments products and application solutions:

Products

Audio	www.ti.com/audio
Amplifiers	amplifier.ti.com
Data Converters	dataconverter.ti.com
DLP® Products	www.dlp.com
DSP	dsp.ti.com
Clocks and Timers	www.ti.com/clocks
Interface	interface.ti.com
Logic	logic.ti.com
Power Mgmt	power.ti.com
Microcontrollers	microcontroller.ti.com
RFID	www.ti-rfid.com
OMAP Mobile Processors	www.ti.com/omap
Wireless Connectivity	www.ti.com/wirelessconnectivity

Applications

Communications and Telecom	www.ti.com/communications
Computers and Peripherals	www.ti.com/computers
Consumer Electronics	www.ti.com/consumer-apps
Energy and Lighting	www.ti.com/energy
Industrial	www.ti.com/industrial
Medical	www.ti.com/medical
Security	www.ti.com/security
Space, Avionics and Defense	www.ti.com/space-avionics-defense
Transportation and Automotive	www.ti.com/automotive
Video and Imaging	www.ti.com/video

TI E2E Community Home Page

e2e.ti.com

Mailing Address: Texas Instruments, Post Office Box 655303, Dallas, Texas 75265
Copyright © 2011, Texas Instruments Incorporated