

25-BIT CONFIGURABLE REGISTERED BUFFER WITH ADDRESS-PARITY TEST

FEATURES

- Member of the Texas Instruments Widebus+™ Family
- Pinout Optimizes DDR2 DIMM PCB Layout
- Configurable as 25-Bit 1:1 or 14-Bit 1:2 Registered Buffer
- Chip-Select Inputs Gate the Data Outputs from Changing State and Minimizes System Power Consumption
- Output Edge-Control Circuitry Minimizes Switching Noise in an Unterminated Line
- Supports SSTL_18 Data Inputs
- Differential Clock (CLK and $\overline{\text{CLK}}$) Inputs
- Supports LVCMOS Switching Levels on the Control and $\overline{\text{RESET}}$ Inputs
- Checks Parity on DIMM-Independent Data Inputs
- Able to Cascade with a Second 74SSTUB32866A
- $\overline{\text{RESET}}$ Input Disables Differential Input Receivers, Resets All Registers, and Forces All Outputs Low, Except $\overline{\text{QERR}}$

DESCRIPTION

This 25-bit 1:1 or 14-bit 1:2 configurable registered buffer is designed for 1.7-V to 1.9-V VCC operation. In the 1:1 pinout configuration, only one device per DIMM is required to drive nine SDRAM loads. In the 1:2 pinout configuration, two devices per DIMM are required to drive 18 SDRAM loads.

All inputs are SSTL_18, except the reset ($\overline{\text{RESET}}$) and control (Cn) inputs, which are LVCMOS. All outputs are edge-controlled circuits optimized for unterminated DIMM loads and meet SSTL_18 specifications, except the open-drain error ($\overline{\text{QERR}}$) output.

The 74SSTUB32866A operates from a differential clock (CLK and $\overline{\text{CLK}}$). Data are registered at the crossing of CLK going high and $\overline{\text{CLK}}$ going low.

The 74SSTUB32866A accepts a parity bit from the memory controller on the parity bit (PAR_IN) input, compares it with the data received on the DIMM-independent D-inputs (D2–D3, D5–D6, D8–D25 when C0 = 0 and C1 = 0; D2–D3, D5–D6, D8–D14 when C0 = 0 and C1 = 1; or D1–D6, D8–D13 when C0 = 1 and C1 = 1) and indicates whether a parity error has occurred on the open-drain $\overline{\text{QERR}}$ pin (active low). The convention is even parity; i.e., valid parity is defined as an even number of ones across the DIMM-independent data inputs, combined with the parity input bit. To calculate parity, all DIMM-independent data inputs must be tied to a known logic state.

When used as a single device, the C0 and C1 inputs are tied low. In this configuration, parity is checked on the PAR_IN input signal, which arrives one cycle after the input data to which it applies. Two clock cycles after the data are registered, the corresponding partial-parity-out (PPO) and $\overline{\text{QERR}}$ signals are generated.

When used in pairs, the C0 input of the first register is tied low, and the C0 input of the second register is tied high. The C1 input of both registers are tied high. Parity, which arrives one cycle after the data input to which it applies, is checked on the PAR_IN input signal of the first device. Two clock cycles after the data are registered, the corresponding PPO and $\overline{\text{QERR}}$ signals are generated on the second device. The PPO output of the first register is cascaded to the PAR_IN of the second 74SSTUB32866A. The $\overline{\text{QERR}}$ output of the first 74SSTUB32866A is left floating, and the valid error information is latched on the $\overline{\text{QERR}}$ output of the second 74SSTUB32866A.

ORDERING INFORMATION

T _A	PACKAGE ⁽¹⁾		ORDERABLE PART NUMBER	TOP-SIDE MARKING
-40°C to 85°C	LFBGA–ZKE	Tape and reel	74SSTUB32866AZKER	SB866A

(1) Package drawings, standard packing quantities, thermal data, symbolization, and PCB design guidelines are available at www.ti.com/sc/package.



Please be aware that an important notice concerning availability, standard warranty, and use in critical applications of Texas Instruments semiconductor products and disclaimers thereto appears at the end of this data sheet.

Widebus+ is a trademark of Texas Instruments.

DESCRIPTION (CONTINUED)

If an error occurs and the \overline{QERR} output is driven low, it stays latched low for a minimum of two clock cycles or until \overline{RESET} is driven low. If two or more consecutive parity errors occur, the \overline{QERR} output is driven low and latched low for a clock duration equal to the parity-error duration or until \overline{RESET} is driven low. The DIMM-dependent signals (\overline{DCKE} , \overline{DCS} , \overline{DODT} , and \overline{CSR}) are not included in the parity-check computation.

The C0 input controls the pinout configuration of the 1:2 pinout from register-A configuration (when low) to register-B configuration (when high). The C1 input controls the pinout configuration from 25-bit 1:1 (when low) to 14-bit 1:2 (when high). C0 and C1 should not be switched during normal operation. They should be hard-wired to a valid low or high level to configure the register in the desired mode. In the 25-bit 1:1 pinout configuration, the A6, D6, and H6 terminals are driven low and are do-not-use (DNU) pins.

In the DDR2 RDIMM application, \overline{RESET} is specified to be completely asynchronous with respect to CLK and \overline{CLK} . Therefore, no timing relationship can be ensured between the two. When entering reset, the register is cleared, and the data outputs are driven low quickly, relative to the time required to disable the differential input receivers. However, when coming out of reset, the register becomes active quickly, relative to the time required to enable the differential input receivers. As long as the data inputs are low, and the clock is stable during the time from the low-to-high transition of \overline{RESET} until the input receivers are fully enabled, the design of the 74SSTUB32866A ensures that the outputs remain low, thus ensuring there will be no glitches on the output.

To ensure defined outputs from the register before a stable clock has been supplied, \overline{RESET} must be held in the low state during power up.

The device supports low-power standby operation. When \overline{RESET} is low, the differential input receivers are disabled, and undriven (floating) data, clock, and reference voltage (V_{REF}) inputs are allowed. In addition, when \overline{RESET} is low, all registers are reset and all outputs are forced low, except \overline{QERR} . The LVCMOS \overline{RESET} and Cn inputs always must be held at a valid logic high or low level.

The device also supports low-power active operation by monitoring both system chip select (\overline{DCS} and \overline{CSR}) inputs and gates the Qn and PPO outputs from changing states when both \overline{DCS} and \overline{CSR} inputs are high. If either DCS or CSR input is low, the Qn and PPO outputs function normally. Also, if the internal low-power signal (LPS1) is high (one cycle after \overline{DCS} and \overline{CSR} go high), the device gates the \overline{QERR} output from changing states. If LPS1 is low, the \overline{QERR} output functions normally. The \overline{RESET} input has priority over the \overline{DCS} and \overline{CSR} control and, when driven low, forces the Qn and PPO outputs low and forces the \overline{QERR} output high. If the \overline{DCS} control functionality is not desired, the \overline{CSR} input can be hard-wired to ground, in which case the setup-time requirement for \overline{DCS} is the same as for the other D data inputs. To control the low-power mode with \overline{DCS} only, the \overline{CSR} input should be pulled up to V_{CC} through a pullup resistor.

The two V_{REF} pins (A3 and T3) are connected together internally by approximately 150 Ω . However, it is necessary to connect only one of the two V_{REF} pins to the external V_{REF} power supply. An unused V_{REF} pin should be terminated with a V_{REF} coupling capacitor.

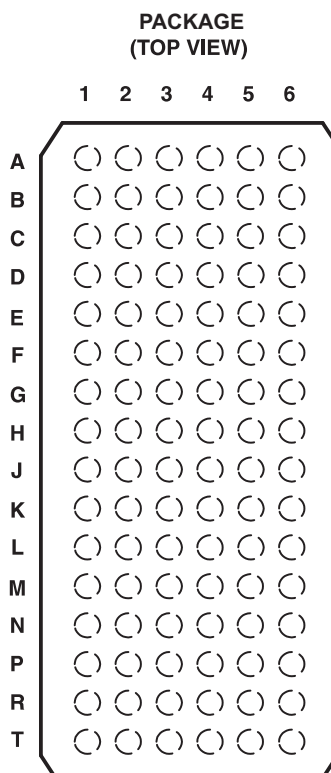

Terminal Assignments for 1:1 Register-A (C0 = 0, C1 = 0)

	1	2	3	4	5	6
A	D1 (DCKE)	PPO	V _{REF}	V _{CC}	Q1 (QCKE)	DNU
B	D2	D15	GND	GND	Q2	Q15
S	D3	D16	V _{CC}	V _{CC}	Q3	Q16
D	D4 (DODT)	$\overline{\text{QERR}}$	GND	GND	Q4 (QODT)	DNU
E	D5	D17	V _{CC}	V _{CC}	Q5	Q17
F	D6	D18	GND	GND	Q6	Q18
G	PAR_IN	$\overline{\text{RESET}}$	V _{CC}	V _{CC}	C1	C0
H	CLK	D7 ($\overline{\text{DCS}}$)	GND	GND	Q7 ($\overline{\text{QCS}}$)	DNU
J	$\overline{\text{CLK}}$	$\overline{\text{CSR}}$	V _{CC}	V _{CC}	NC	NC
K	D8	D19	GND	GND	Q8	Q19
L	D9	D20	V _{CC}	V _{CC}	Q9	Q20
M	D10	D21	GND	GND	Q10	Q21
N	D11	D22	V _{CC}	V _{CC}	Q11	Q22
P	D12	D23	GND	GND	Q12	Q23
R	D13	D24	V _{CC}	V _{CC}	Q13	Q24
T	D14	D25	V _{REF}	V _{CC}	Q14	Q25

Each pin name in parentheses indicates the DDR2 DIMM signal name.

DNU - Do not use

NC - No internal connection

Logic Diagram for 1:1 Register Configuration (Positive Logic); C0 = 0, C1 = 0

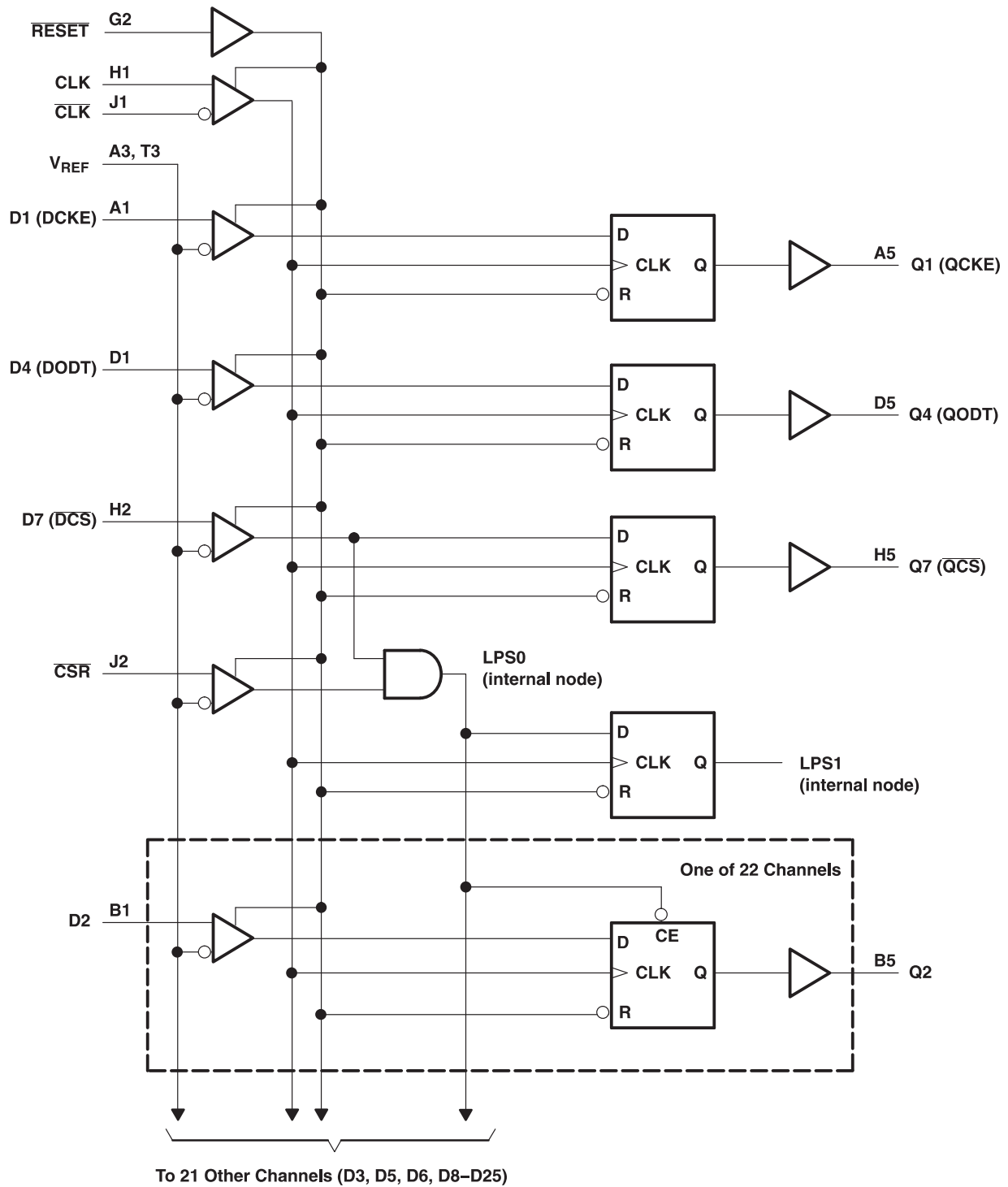

Parity Logic Diagram for 1:1 Register Configuration (Positive Logic); C0 = 0, C1 = 0

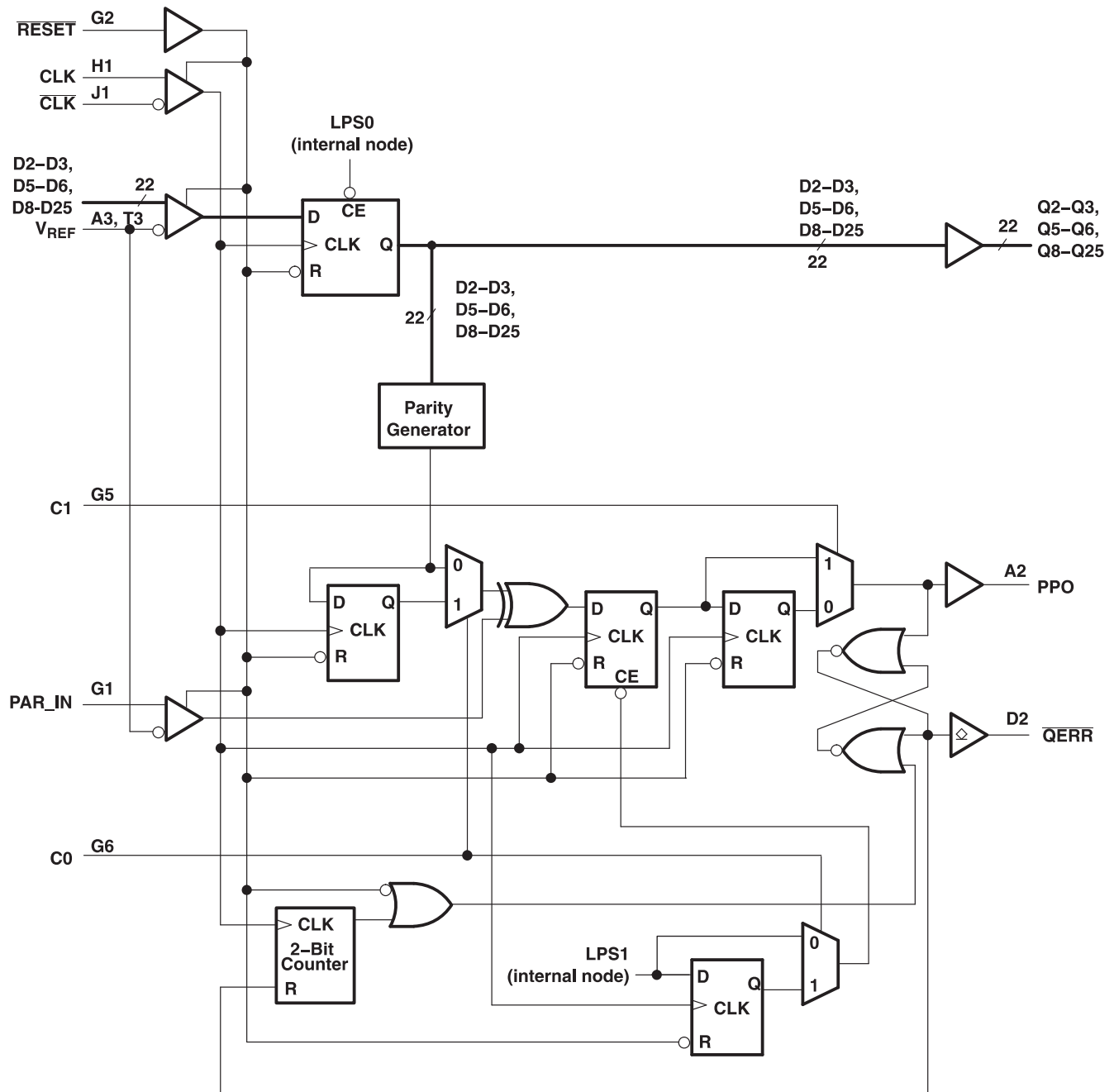

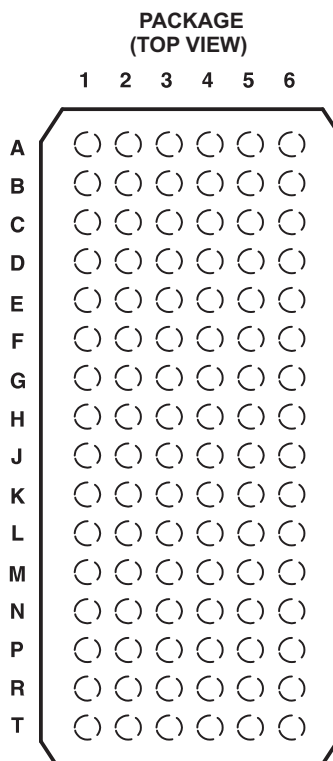

	1	2	3	4	5	6
A	D1 (DCKE)	PPO	V _{REF}	V _{CC}	Q1A (QCKEA)	Q1B (QCKEB)
B	D2	DNU	GND	GND	Q2A	Q2B
S	D3	DNU	V _{CC}	V _{CC}	Q3A	Q3B
D	D4 (DODT)	\overline{QERR}	GND	GND	Q4A (QODTA)	Q4B(QODTB)
E	D5	DNU	V _{CC}	V _{CC}	Q5A	Q5B
F	D6	DNU	GND	GND	Q6A	Q6B
G	PAR_IN	\overline{RESET}	V _{CC}	V _{CC}	C1	C0
H	CLK	D7 (\overline{DCS})	GND	GND	Q7A (\overline{QCSA})	Q7B (\overline{QCSB})
J	\overline{CLK}	\overline{CSR}	V _{CC}	V _{CC}	NC	NC
K	D8	DNU	GND	GND	Q8A	Q8B
L	D9	DNU	V _{CC}	V _{CC}	Q9A	Q9B
M	D10	DNU	GND	GND	Q10A	Q10B
N	D11	DNU	V _{CC}	V _{CC}	Q11A	Q11B
P	D12	DNU	GND	GND	Q12A	Q12B
R	D13	DNU	V _{CC}	V _{CC}	Q13A	Q13B
T	D14	DNU	V _{REF}	V _{CC}	Q14A	Q14B

Each pin name in parentheses indicates the DDR2 DIMM signal name.

DNU - Do not use

NC - No internal connection

Logic Diagram for 1:2 Register-A Configuration (Positive Logic); C0 = 0, C1 = 1

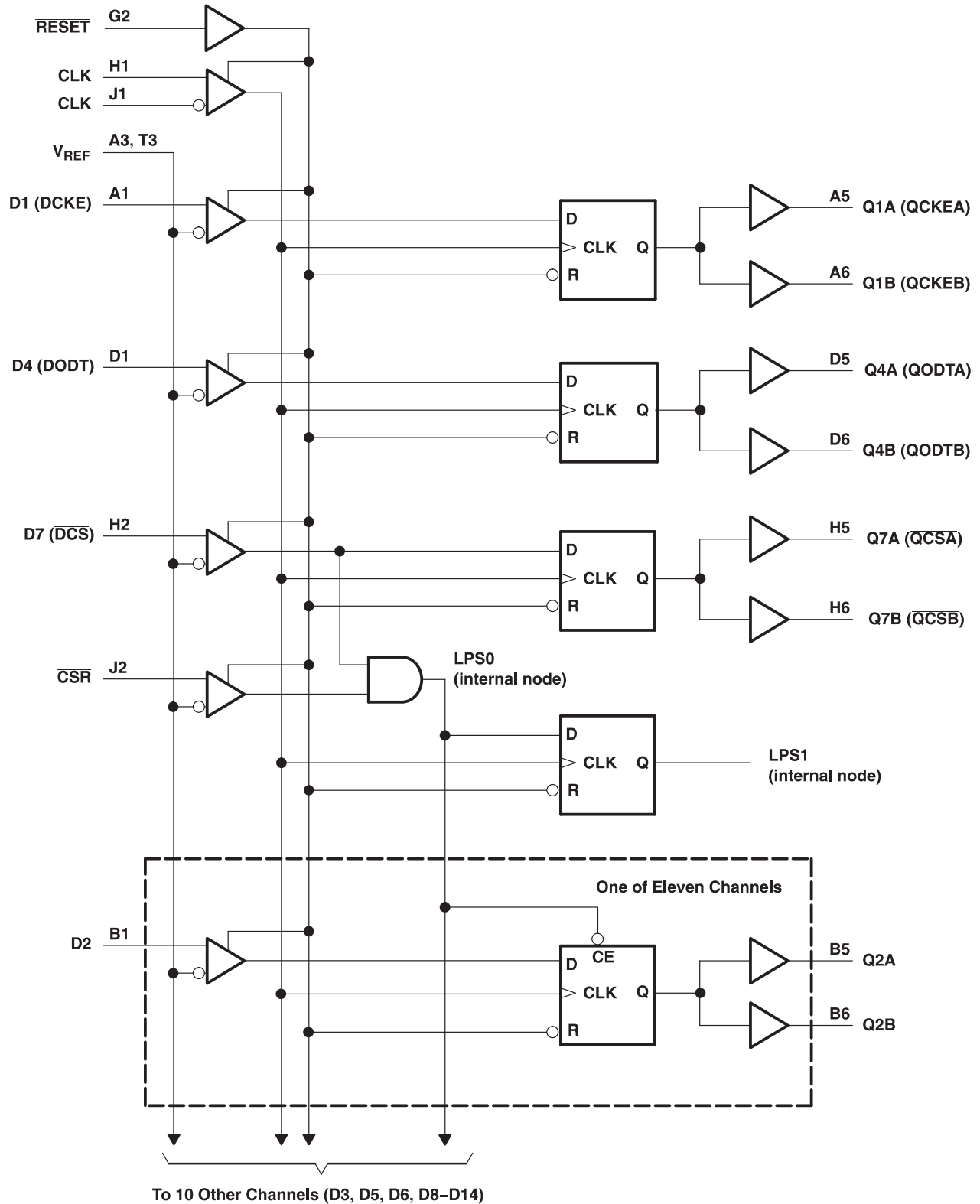

Parity Logic Diagram for 1:2 Register-A Configuration (Positive Logic); C0 = 0, C1 = 1

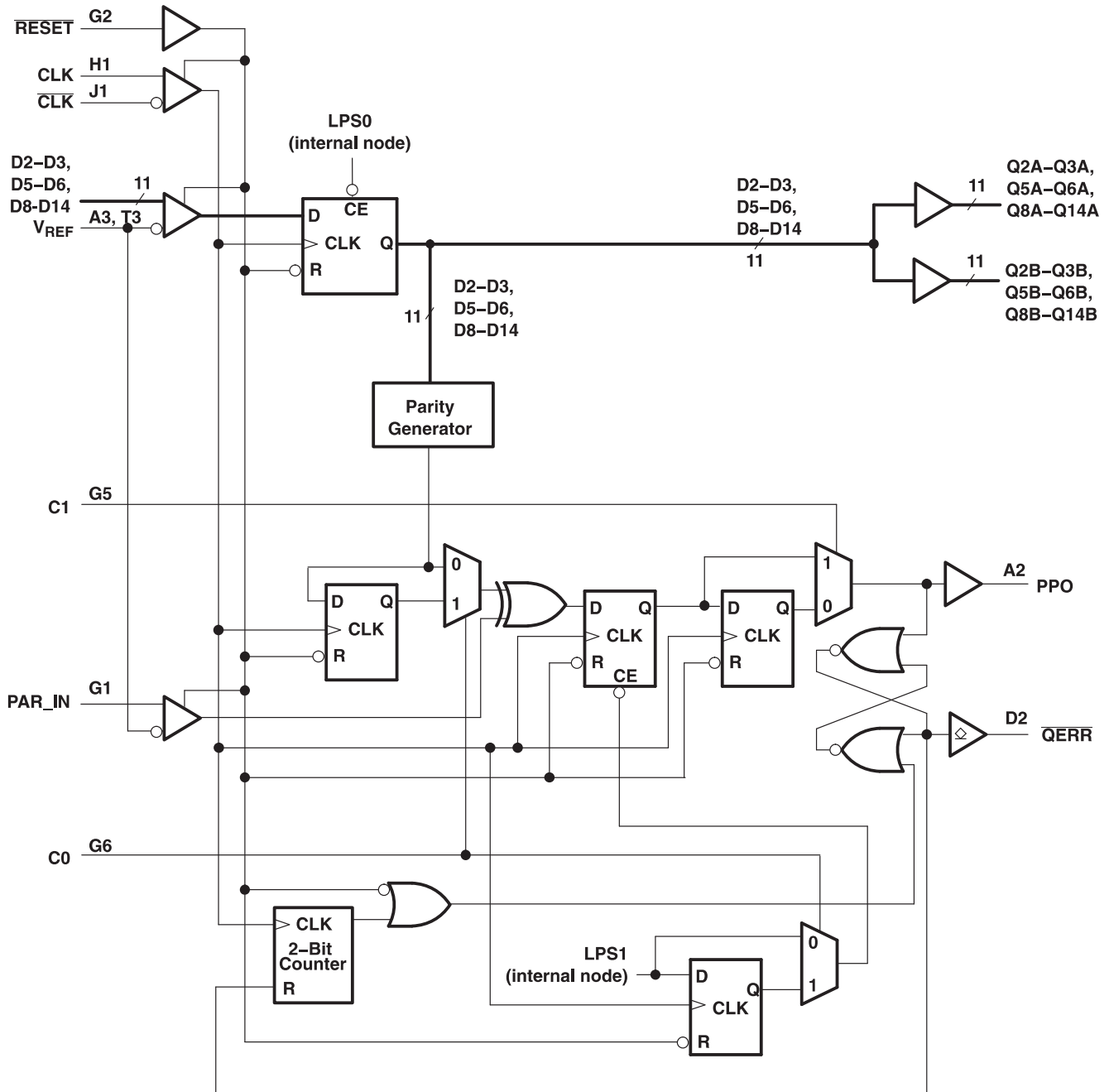

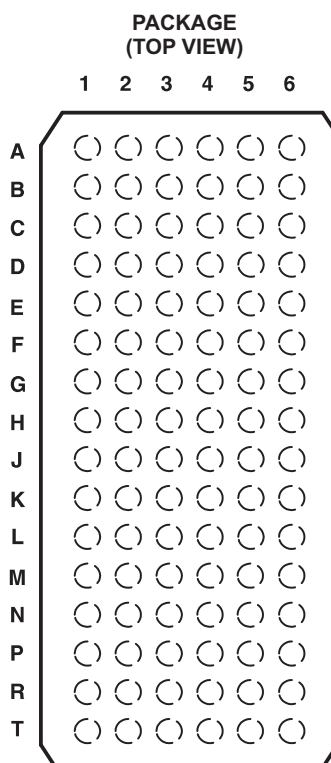

Terminal Assignments for 1:2 Register-b (C0 = 1, C1 = 1)

	1	2	3	4	5	6
A	D1	PPO	V _{REF}	V _{CC}	Q1A	Q1B
B	D2	DNU	GND	GND	Q2A	Q2B
S	D3	DNU	V _{CC}	V _{CC}	Q3A	Q3B
D	D4	\overline{QERR}	GND	GND	Q4A	Q4B
E	D5	DNU	V _{CC}	V _{CC}	Q5A	Q5B
F	D6	DNU	GND	GND	Q6A	Q6B
G	PAR_IN	\overline{RESET}	V _{CC}	V _{CC}	C1	C0
H	CLK	D7 (\overline{DCS})	GND	GND	Q7A (\overline{QCSA})	Q7B (\overline{QCSB})
J	\overline{CLK}	\overline{CSR}	V _{CC}	V _{CC}	NC	NC
K	D8	DNU	GND	GND	Q8A	Q8B
L	D9	DNU	V _{CC}	V _{CC}	Q9A	Q9B
M	D10	DNU	GND	GND	Q10A	Q10B
N	D11 (DODT)	DNU	V _{CC}	V _{CC}	Q11A (QODTA)	Q11B (QODTB)
P	D12	DNU	GND	GND	Q12A	Q12B
R	D13	DNU	V _{CC}	V _{CC}	Q13A	Q13B
T	D14 (DCKE)	DNU	V _{REF}	V _{CC}	Q14A (QCKEA)	Q14B (QCKEB)

Each pin name in parentheses indicates the DDR2 DIMM signal name.

DNU - Do not use

NC - No internal connection

Logic Diagram for 1:2 Register-B Configuration C0 = 1, C1 = 1

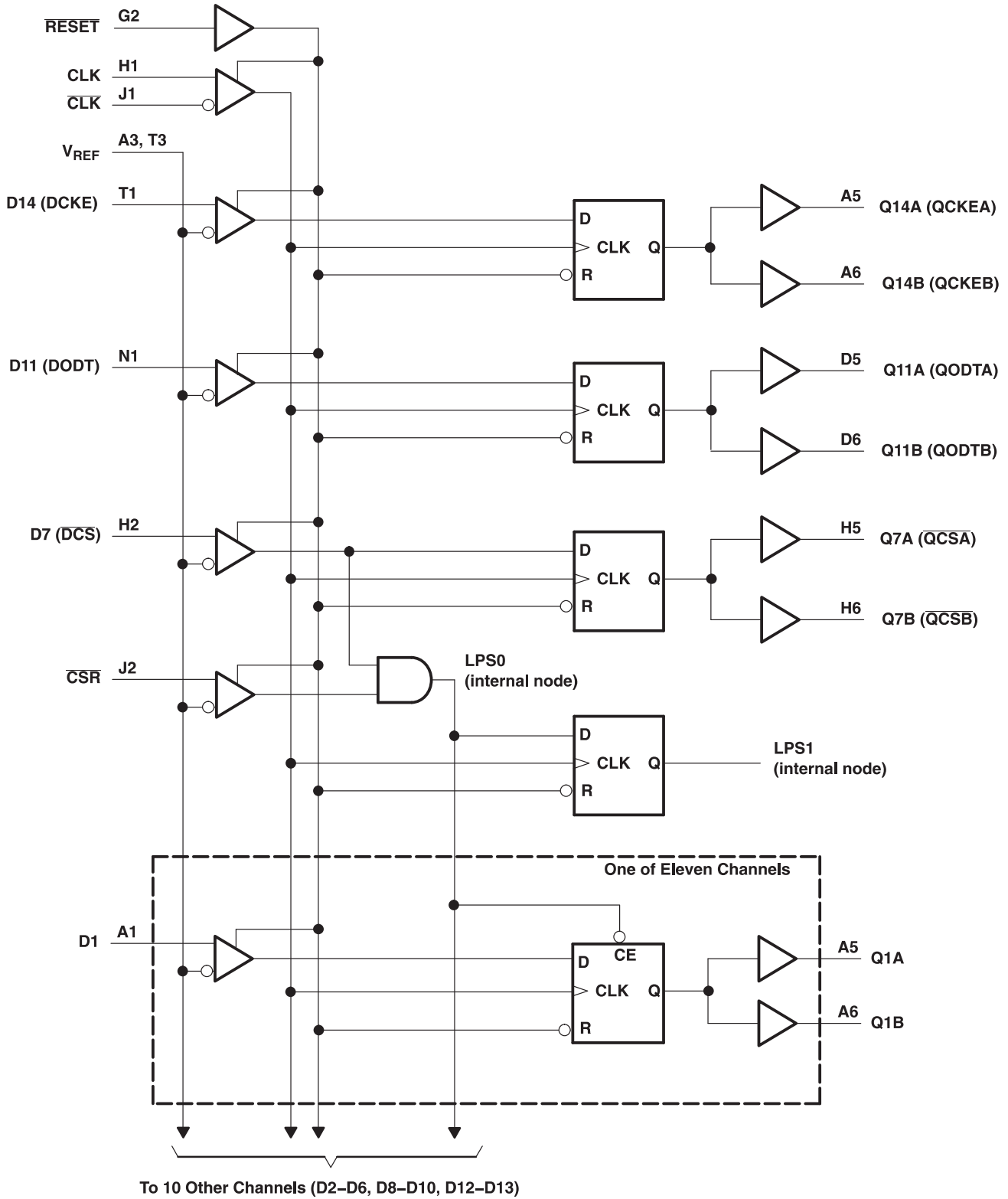

Parity Logic Diagram for 1:2 Register-b Configuration (Positive Logic); C0 = 1, C1 = 1

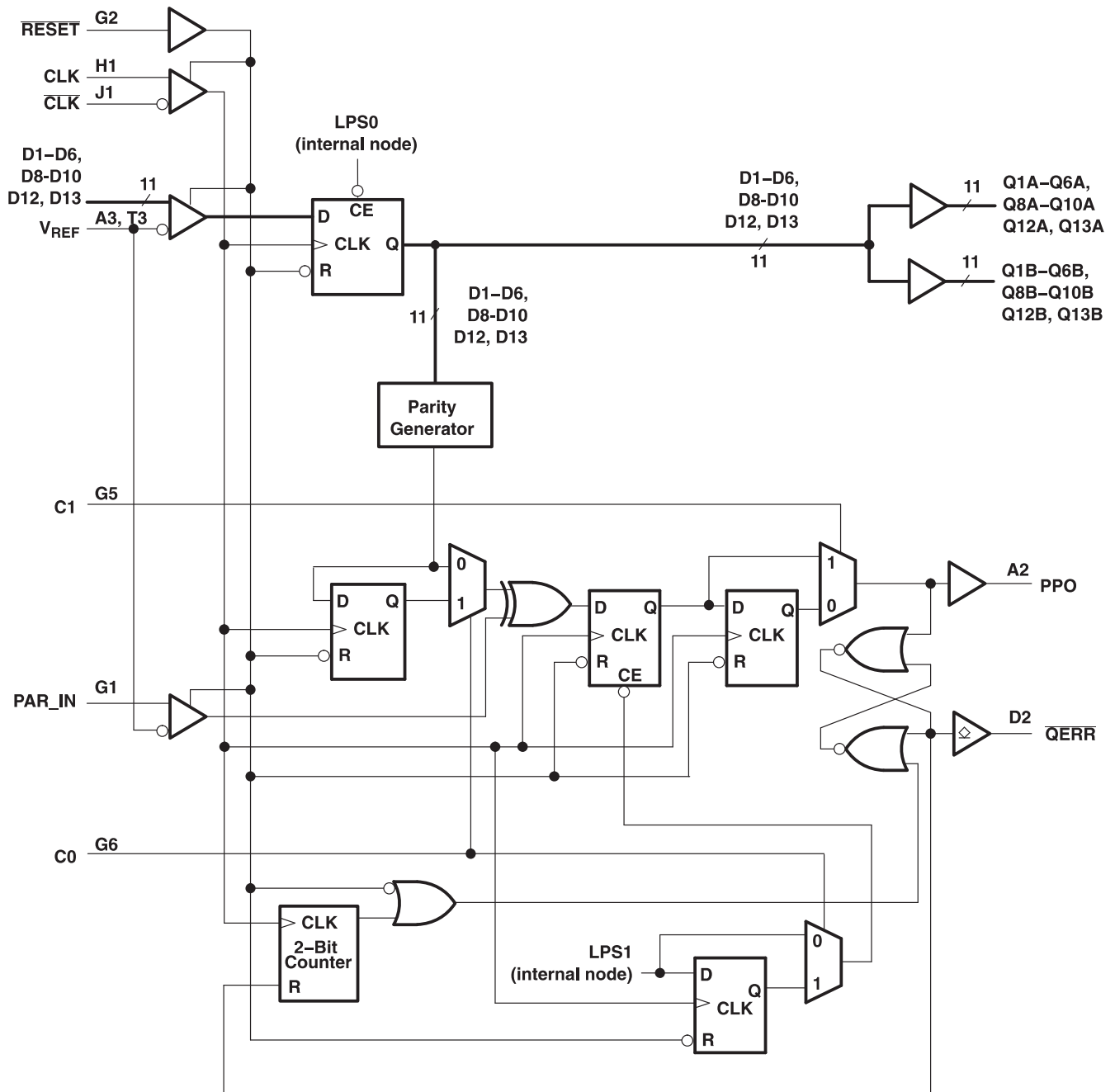

TERMINAL FUNCTIONS

TERMINAL NAME	DESCRIPTION	ELECTRICAL CHARACTERISTICS
GND	Ground	Ground input
V _{CC}	Power-supply voltage	1.8 V nominal
V _{REF}	Input reference voltage	0.9 V nominal
CLK	Positive master clock input	Differential input
$\overline{\text{CLK}}$	Negative master clock input	Differential input
C0, C1	Configuration control input. Register A or Register B and 1:1 mode or 1:2 mode select.	LVC MOS inputs
$\overline{\text{RESET}}$	Asynchronous reset input. Resets registers and disables V _{REF} , data, and clock differential-input receivers. When $\overline{\text{RESET}}$ is low, all Q outputs are forced low and the $\overline{\text{QERR}}$ output is forced high.	LVC MOS input
D1-D25	Data input. Clocked in on the crossing of the rising edge of CLK and the falling edge of $\overline{\text{CLK}}$.	SSTL ₁₈ inputs
$\overline{\text{CSR}}$, $\overline{\text{DCS}}$	Chip select inputs. Disables D1–D25 ⁽¹⁾ outputs switching when both inputs are high	SSTL ₁₈ inputs
DODT	The outputs of this register bit will not be suspended by the $\overline{\text{DCS}}$ and $\overline{\text{CSR}}$ control.	SSTL ₁₈ input
DCKE	The outputs of this register bit will not be suspended by the $\overline{\text{DCS}}$ and $\overline{\text{CSR}}$ control.	SSTL ₁₈ input
PAR_IN	Parity input. Arrives one clock cycle after the corresponding data input. Pull-down resistor of typical 150k Ω to GND.	SSTL ₁₈ input pull-down
Q1–Q25 ⁽²⁾	Data outputs that are suspended by the $\overline{\text{DCS}}$ and $\overline{\text{CSR}}$ control.	1.8 V CMOS outputs
PPO	Partial parity out. Indicates odd parity of inputs D1–D25. ⁽¹⁾	1.8 V CMOS output
$\overline{\text{QCS}}$	Data output that will not be suspended by the $\overline{\text{DCS}}$ and $\overline{\text{CSR}}$ control	1.8 V CMOS output
QODT	Data output that will not be suspended by the $\overline{\text{DCS}}$ and $\overline{\text{CSR}}$ control	1.8 V CMOS output
QCKE	Data output that will not be suspended by the $\overline{\text{DCS}}$ and $\overline{\text{CSR}}$ control	1.8 V CMOS output
$\overline{\text{QERR}}$	Output error bit. Timing is determined by the device mode.	Open-drain output
NC	No internal connection	
DNU	Do not use. Inputs are in standby-equivalent mode, and outputs are driven low.	

- (1) Data inputs = D2, D3, D5, D6, D8-D25 when C0 = 0 and C1 = 0
 Data inputs = D2, D3, D5, D6, D8-D14 when C0 = 0 and C1 = 1
 Data inputs = D1-D6, D8-D10, D12, D13 when C0 = 1 and C1 = 1, D
- (2) Data outputs = Q2, Q3, Q5, Q6, Q8-Q25 when C0 = 0 and C1 = 0
 Data outputs = Q2, Q3, Q5, Q6, Q8-Q14 when C0 = 0 and C1 = 1
 Data outputs = Q1-Q6, Q8-Q10, Q12, Q13 when C0 = 1 and C1 = 1.

FUNCTION TABLE

INPUTS						OUTPUTS
RESET	DCS	$\overline{\text{CSR}}$	CLK	$\overline{\text{CLK}}$	D _n	Q _n
H	L	X	↑	↓	L	L
H	L	X	↑	↓	H	H
H	X	L	↑	↓	L	L
H	X	L	↑	↓	H	H
H	H	H	↑	↓	X	Q ₀
H	X	X	L or H	L or H	X	Q ₀
L	X or Floating	X or Floating	X or Floating	X or Floating	X or Floating	L

FUNCTION TABLE

INPUTS			OUTPUTS
RESET	CLK	$\overline{\text{CLK}}$	DCKE, $\overline{\text{DCS}}$, DODT, QCKE, $\overline{\text{QCS}}$, QODT
H	↑	↓	H
H	↑	↓	L
H	L or H	L or H	X
L	X or Floating	X or Floating	X or Floating
L	X or Floating	X or Floating	L

PARITY AND STANDBY FUNCTION

INPUTS							OUTPUTS	
RESET	CLK	CLK	DCS	CSR	Σ OF INPUTS = H D1–D25 ⁽¹⁾	PAR_IN ⁽²⁾	PPO	QERR ⁽³⁾
H	↑	↓	L	X	Even	L	L	H
H	↑	↓	L	X	Odd	L	H	L
H	↑	↓	L	X	Even	H	H	L
H	↑	↓	L	X	Odd	H	L	H
H	↑	↓	H	L	Even	L	L	H
H	↑	↓	H	L	Odd	L	H	L
H	↑	↓	H	L	Even	H	H	L
H	↑	↓	H	L	Odd	H	L	H
H	↑	↓	H	H	X	X	PPO ₀	QERR ₀
H	L or H	L or H	X	X	X	X	PPO ₀	QERR ₀
L	X or Floating	X or Floating	X or Floating	X or Floating	X	X or Floating	L	H

- (1) Data inputs = D2-D3, D5-D6, D8-D25 when C0 = 0 and C1 = 0
Data inputs = D2-D3, D5-D6, D8-D14 when C0 = 0 and C1 = 1
Data inputs = D1-D6, D8-D10, D12, D13 when C0 = 1 and C1 = 1
- (2) PAR_IN arrives one clock cycle (C0 = 0) or two clock cycles (C0 = 1) after the data to which it applies.
- (3) This transition assumes that QERR is high at the crossing of CLK going high and CLK going low. If QERR goes low, it stays latched low for a minimum of two clock cycles or until RESET is driven low. If two or more consecutive parity errors occur, the QERR output is driven low and latched low for a clock duration equal to the parity duration or until RESET is driven low.

PARITY ERROR DETECT IN LOW-POWER MODE⁽¹⁾

INPUT-DATA ERROR OCCURRENCE ⁽²⁾	1:1 MODE (C0 = 0, C1 = 0)		1:2 REGISTER-A MODE (C0 = 0, C1 = 1)		1:2 REGISTER-B MODE (C0 = 1, C1 = 1)		CASCADED MODE (Registers A and B)	
	PPO DURATION ⁽³⁾	QERR DURATION ⁽³⁾	PPO DURATION ⁽³⁾	QERR DURATION ⁽³⁾	PPO DURATION ⁽³⁾	QERR DURATION ⁽³⁾	PPO DURATION ⁽³⁾	QERR DURATION ⁽³⁾
n – 4	1 Cycle	2 Cycles	1 Cycle	2 Cycles	1 Cycle	2 Cycles	1 Cycle	2 Cycles
n – 3	1 Cycle	2 Cycles	1 Cycle	2 Cycles	1 Cycle	2 Cycles	1 Cycle	2 Cycles
n – 2	1 Cycle	2 Cycles	1 Cycle	2 Cycles	1 Cycle	2 Cycles	1 Cycle	2 Cycles
n – 1	LPM + 2 Cycles	LPM + 2 Cycles	LPM + 1 Cycle	LPM + 1 Cycle	LPM + 2 Cycles	LPM + 2 Cycles	LPM + 2 Cycles	LPM + 2 Cycles
n	Not detected	Not detected	Not detected	Not detected	Not detected	Not detected	Not detected	Not detected

- (1) If a parity error occurs before the device enters the low-power mode (LPM), the behavior of PPO and QERR is dependent on the mode of the device and the position of the parity error occurrence. This table illustrates the low-power-mode effect on parity detect. The low-power mode is activated on the n clock cycle when DCS and CSR go high.
- (2) The clock-edge position of a one cycle data-input error relative to the clock-edge (n) which initiates LPM at the DCS and CSR inputs.
- (3) If an error occurs, then QERR output may be driven low and the PPO output driven high. These columns show the clock duration for which the PPO signal will be high.

ABSOLUTE MAXIMUM RATINGSover operating free-air temperature range (unless otherwise noted) ⁽¹⁾

		VALUE	UNIT	
V _{CC}	Supply voltage range	–0.5 to 2.5	V	
V _I	Input voltage range ⁽²⁾ ⁽³⁾	–0.5 to V _{CC} + 0.5	V	
V _O	Output voltage range ⁽²⁾ ⁽³⁾	–0.5 to V _{CC} + 0.5	V	
I _{IK}	Input clamp current, (V _I < 0 or V _I > V _{CC})	±50	mA	
I _{OK}	Output clamp current, (V _O < 0 or V _O > V _{CC})	±50	mA	
I _O	Continuous output current (V _O = 0 to V _{CC})	±50	mA	
I _{CCC}	Continuous current through each V _{CC} or GND	±100	mA	
R _{θJA}	Thermal impedance, junction-to-ambient ⁽⁴⁾	No airflow	39.8	K/W
		Airflow 150 ft/min	34.1	
		Airflow 250 ft/min	33.6	
		Airflow 500 ft/min	32.5	
R _{θJB}	Thermal resistance, junction-to-board ⁽⁴⁾	No airflow	14.5	
T _{stg}	Storage temperature range	–65 to 150	°C	

(1) Stresses beyond those listed under *absolute maximum ratings* may cause permanent damage to the device. These are stress ratings only, and functional operation of the device at these or any other conditions beyond those indicated under *recommended operating conditions* is not implied. Exposure to absolute-maximum-rated conditions for extended periods may affect device reliability.

(2) The input and output negative-voltage ratings may be exceeded if the input and output clamp-current ratings are observed.

(3) This value is limited to 2.5 V maximum.

(4) The package thermal impedance is calculated in accordance with JESD 51-7.

RECOMMENDED OPERATING CONDITIONS⁽¹⁾

		MIN	NOM	MAX	UNIT
V _{CC}	Supply voltage	1.7		1.9	V
V _{REF}	Reference voltage	0.49 × V _{CC}	0.5 × V _{CC}	0.51 × V _{CC}	V
V _{TT}	Termination voltage	V _{REF} –40 mV	V _{REF}	V _{REF} + 40 mV	V
V _I	Input voltage	0		V _{CC}	V
V _{IH}	AC high-level input voltage	Data inputs, $\overline{\text{CSR}}$, PAR_IN	V _{REF} + 250 mV		V
V _{IL}	AC low-level input voltage	Data inputs, $\overline{\text{CSR}}$, PAR_IN		V _{REF} –250 mV	V
V _{IH}	DC high-level input voltage	Data inputs, $\overline{\text{CSR}}$, PAR_IN	V _{REF} + 125 mV		V
V _{IL}	DC low-level input voltage	Data inputs, $\overline{\text{CSR}}$, PAR_IN		V _{REF} –125 mV	V
V _{IH}	High-level input voltage	$\overline{\text{RESET}}$, C _n	0.65 × V _{CC}		V
V _{IL}	Low-level input voltage	$\overline{\text{RESET}}$, C _n		0.35 × V _{CC}	V
V _{ICR}	Common-mode input voltage range	CLK, $\overline{\text{CLK}}$	0.675	1.125	V
V _{I(PP)}	Peak-to-peak input voltage	CLK, $\overline{\text{CLK}}$	600		mV
I _{OH}	High-level output current	Q outputs, PPO		–8	mA
I _{OL}	Low-level output current	Q outputs, PPO		8	mA
		$\overline{\text{QERR}}$ output	30		
T _A	Operating free-air temperature	–40		85	°C

(1) The $\overline{\text{RESET}}$ and C_n inputs of the device must be held at valid logic voltage levels (not floating) to ensure proper device operation. The differential inputs must not be floating unless $\overline{\text{RESET}}$ is low. See the TI application report, *Implications of Slow or Floating CMOS Inputs* (SCBA004).

ELECTRICAL CHARACTERISTICS

over recommended operating free-air temperature range (unless otherwise noted)

PARAMETER		TEST CONDITIONS		V _{CC}	MIN	TYP ⁽¹⁾	MAX	UNIT
V _{OH}	Q outputs, PPO	I _{OH} = -100 μA		1.7V to 1.9V	V _{CC} -0.2			V
		I _{OH} = -6 mA		1.7V	1.3			
V _{OL}	Q outputs, PPO	I _{OL} = 100 μA		1.7V to 1.9V	0.2			V
		I _{OL} = 6 mA		1.7V	0.4			
	$\overline{\text{QERR}}$ output	I _{OL} = 25 mA		1.7V	0.5			
I _i	PAR_IN	V _i = GND		1.9V	5			μA
		V _i = V _{CC}			25			
	All other inputs ⁽²⁾		V _i = V _{CC} or GND		±5			
I _{OZ}	$\overline{\text{QERR}}$ output	V _O = V _{CC} or GND		1.9V	±10			μA
I _{CC}	Static standby	$\overline{\text{RESET}}$ = GND		1.9V	I _O = 0	200		μA
	Static operating	$\overline{\text{RESET}}$ = V _{CC} , V _i = V _{IH(AC)} or V _{IL(AC)}				40		mA
I _{CCD}	Dynamic operating – clock only	$\overline{\text{RESET}}$ = V _{CC} , V _i = V _{IH(AC)} or V _{IL(AC)} , CLK and $\overline{\text{CLK}}$ switching 50% duty cycle		1.8V	I _O = 0	45		μA/MHz
	Dynamic operating – per each data input, 1:1 configuration	$\overline{\text{RESET}}$ = V _{CC} , V _i = V _{IH(AC)} or V _{IL(AC)} , CLK and $\overline{\text{CLK}}$ switching 50% duty cycle, one data input				43		μA clock MHz/ D input
	Dynamic operating – per each data input, 1:2 configuration	switching at one-half clock frequency, 50% duty cycle				60		
I _{CCDLP}	Chip-select-enabled low-power active mode – clock only	$\overline{\text{RESET}}$ = V _{CC} , V _i = V _{IH(AC)} or V _{IL(AC)} , CLK and $\overline{\text{CLK}}$ switching 50% duty cycle		1.8V	I _O = 0	45		μA/MHz
	Chip-select-enabled low-power active mode - 1:1 configuration	$\overline{\text{RESET}}$ = V _{CC} , V _i = V _{IH(AC)} or V _{IL(AC)} , CLK and $\overline{\text{CLK}}$ switching 50% duty cycle, one data input				2		μA clock MHz/ D input
	Chip-select-enabled low-power active mode – 1:2 configuration	switching at one-half clock frequency, 50% duty cycle				3		
C _i	Data inputs, $\overline{\text{CSR}}$, PAR_IN	V _i = V _{REF} ± 250 mV		1.8V	2.5	3	3.5	pF
	CLK, $\overline{\text{CLK}}$	V _{ICR} = 0.9 V, V _{I(PP)} = 600 mV			2	3		
	$\overline{\text{RESET}}$	V _i = V _{CC} or GND			4			

 (1) All typical values are at V_{CC} = 1.8 V, T_A = 25°C.

 (2) Each V_{REF} pin (A3 or T3) should be tested independently, with the other (untested) pin open.

TIMING REQUIREMENTS

over recommended operating free-air temperature range (unless otherwise noted) (see [Figure 2](#) and ⁽¹⁾)

		$V_{CC} = 1.8\text{ V} \pm 0.1\text{ V}$		UNIT
		MIN	MAX	
f _{clock}	Clock frequency	410		MHz
t _w	Pulse duration, CLK, $\overline{\text{CLK}}$ high or low	1		ns
t _{act}	Differential inputs active time ⁽²⁾	10		ns
t _{inact}	Differential inputs inactive time ⁽³⁾	15		ns
t _{su}	Setup time	$\overline{\text{DCS}}$ before CLK \uparrow , $\overline{\text{CLK}}\downarrow$, $\overline{\text{CSR}}$ high; $\overline{\text{CSR}}$ before CLK \uparrow , $\overline{\text{CLK}}\downarrow$, $\overline{\text{DCS}}$ high		ps
		$\overline{\text{DCS}}$ before CLK \uparrow , $\overline{\text{CLK}}\downarrow$, $\overline{\text{CSR}}$ low		
		DODT, DCKE, and Data before CLK \uparrow , $\overline{\text{CLK}}\downarrow$		
		PAR_IN before CLK \uparrow , $\overline{\text{CLK}}\downarrow$		
t _h	Hold time	$\overline{\text{DCS}}$, DODT, DCKE, and Data after CLK \uparrow , $\overline{\text{CLK}}\downarrow$		ps
		PAR_IN after CLK \uparrow , $\overline{\text{CLK}}\downarrow$		

(1) All inputs slew rate is 1 V/ns \pm 20%.

(2) V_{REF} must be held at a valid input level, and data inputs must be held low for a minimum time of t_{act} max, after RESET is taken high.

(3) V_{REF}, data, and clock inputs must be held at valid voltage levels (not floating) for a minimum time of t_{inact} max, after RESET is taken low.

SWITCHING CHARACTERISTICS

over recommended operating free-air temperature range (unless otherwise noted)

PARAMETER		FROM (INPUT)	TO (OUTPUT)	$V_{CC} = 1.8\text{ V} \pm 0.1\text{ V}$		UNIT
				MIN	MAX	
f _{max}	See Figure 2			410		MHz
t _{pdm}	Production test, See Figure 1	CLK and $\overline{\text{CLK}}$	Q	0.4	0.7	ns
t _{pd}	See Figure 5	CLK and $\overline{\text{CLK}}$	PPO	0.6	1.6	ns
t _{PLH}	See Figure 4	CLK and $\overline{\text{CLK}}$	$\overline{\text{QERR}}$	1.2	2.4	ns
t _{PHL}				1	2.0	
t _{RPHL} ⁽¹⁾	See Figure 2	RESET	Q	3		ns
t _{RPHL}	See Figure 5		PPO	3		
t _{RPLH}	See Figure 5		$\overline{\text{QERR}}$	3		

(1) Includes 350-ps test-load transmission-line delay.

OUTPUT SLEW RATES

over recommended operating free-air temperature range (unless otherwise noted) (see [Figure 2](#))

PARAMETER	FROM	TO	$V_{CC} = 1.8\text{ V} \pm 0.1\text{ V}$		UNIT
			MIN	MAX	
dV/dt _r	20%	80%	1	4	V/ns
dV/dt _f	80%	20%	1	4	V/ns
dV/dt Δ ⁽¹⁾	20% or 80%	80% or 20%	1		V/ns

(1) Difference between dV/dt_r (rising edge rate) and dV/dt_f (falling edge rate).

PARAMETER MEASUREMENT INFORMATION

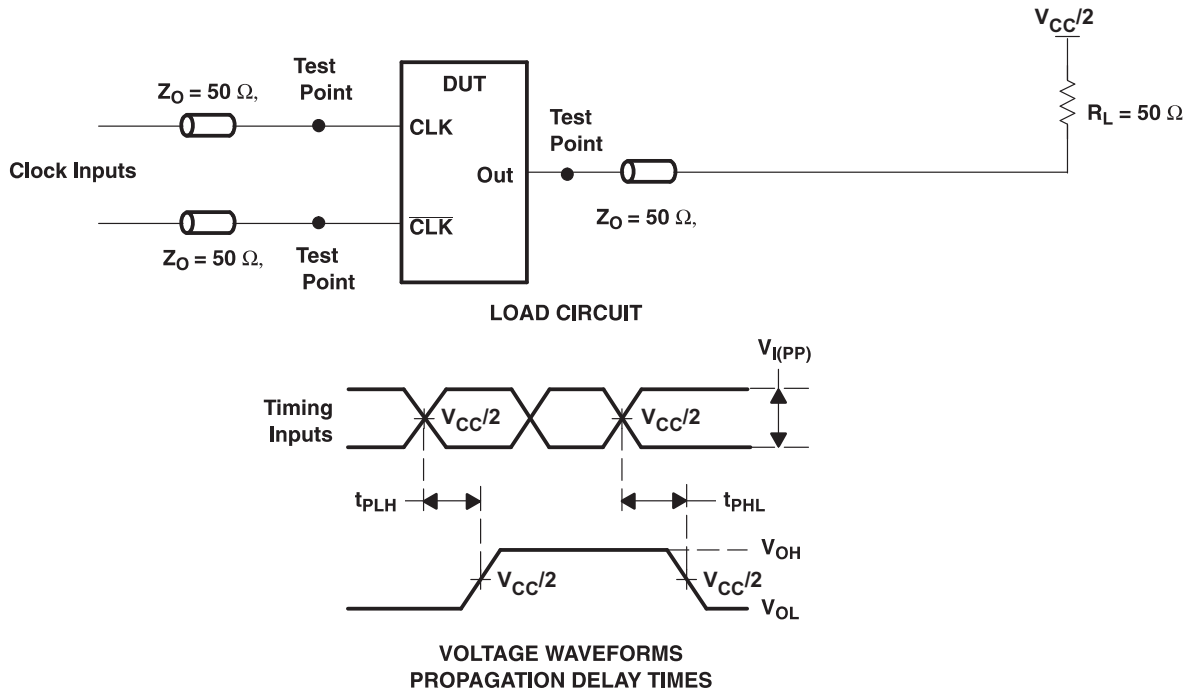
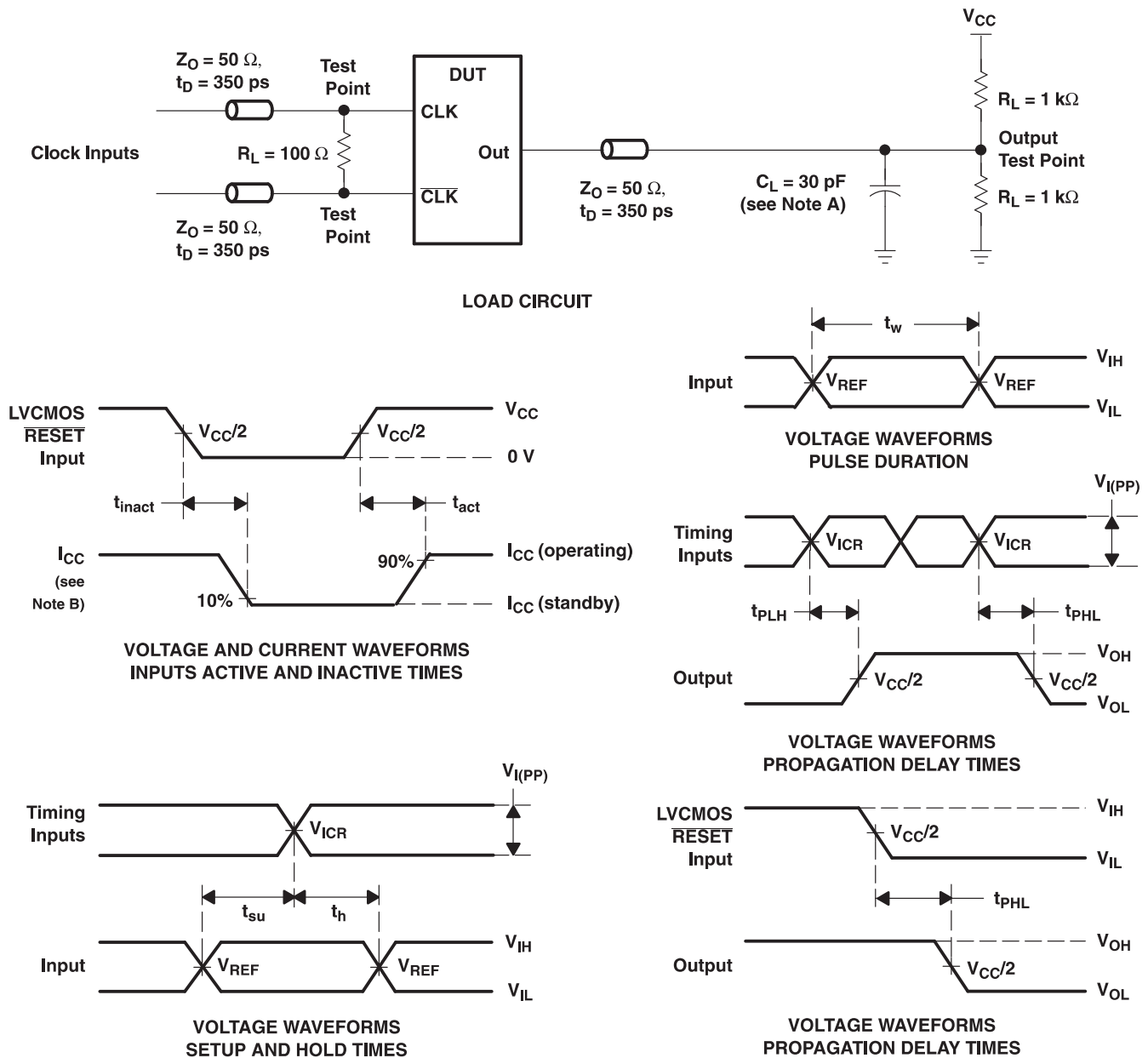

Figure 1. Output Load For Production Test

PROPAGATION DELAY (Design Goal as per JEDEC Specification)

PARAMETER	FROM (INPUT)	TO (OUTPUT)	$V_{CC} = 1.8 V \pm 0.1 V$		UNIT
			MIN	MAX	
$t_{pdm}^{(1)}$	CLK and \overline{CLK}	Q	1.1	1.5	ns
$t_{pdmss}^{(1)}$	CLK and \overline{CLK}	Q		1.6	ns

(1) Includes 350 psi test-load transmission delay line



- NOTES:
- C_L includes probe and jig capacitance.
 - I_{CC} tested with clock and data inputs held at V_{CC} or GND, and $I_O = 0\ \text{mA}$.
 - All input pulses are supplied by generators having the following characteristics: $\text{PRR} \leq 10\ \text{MHz}$, $Z_O = 50\ \Omega$, input slew rate = $1\ \text{V/ns} \pm 20\%$ (unless otherwise noted).
 - The outputs are measured one at a time, with one transition per measurement.
 - $V_{\text{REF}} = V_{\text{TT}} = V_{CC}/2$
 - $V_{\text{IH}} = V_{\text{REF}} + 250\ \text{mV}$ (ac voltage levels) for differential inputs. $V_{\text{IH}} = V_{CC}$ for LVC MOS input.
 - $V_{\text{IL}} = V_{\text{REF}} - 250\ \text{mV}$ (ac voltage levels) for differential inputs. $V_{\text{IL}} = \text{GND}$ for LVC MOS input.
 - $V_{\text{I(PP)}} = 600\ \text{mV}$
 - t_{PLH} and t_{PHL} are the same as t_{pd} .

Figure 2. Data Output Load Circuit and Voltage Waveforms

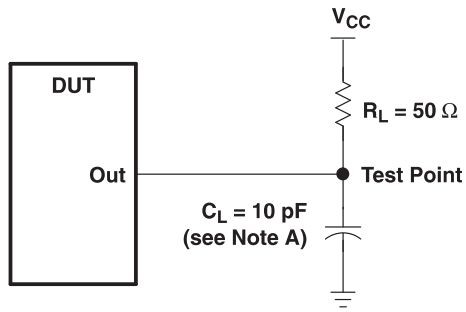

LOAD CIRCUIT
HIGH-TO-LOW SLEW-RATE MEASUREMENT

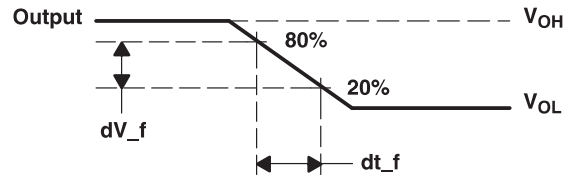

VOLTAGE WAVEFORMS
HIGH-TO-LOW SLEW-RATE MEASUREMENT

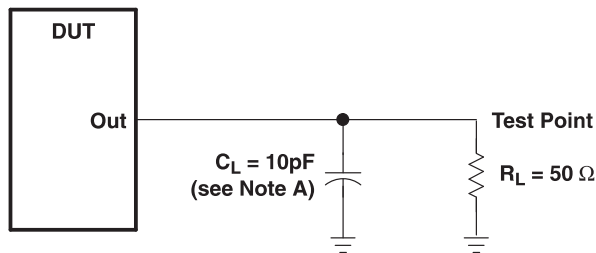

LOAD CIRCUIT
LOW-TO-HIGH SLEW-RATE MEASUREMENT

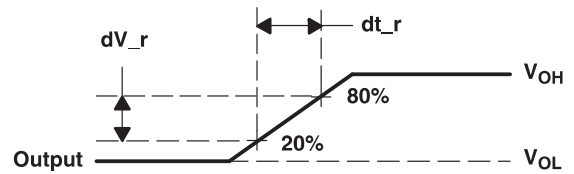

VOLTAGE WAVEFORMS
LOW-TO-HIGH SLEW-RATE MEASUREMENT

- NOTES: A. C_L includes probe and jig capacitance.
 B. All input pulses are supplied by generators having the following characteristics: $PRR \leq 10$ MHz, $Z_O = 50 \Omega$, input slew rate = 1 V/ns $\pm 20\%$ (unless otherwise specified).

Figure 3. Data Output Slew-Rate Measurement Information

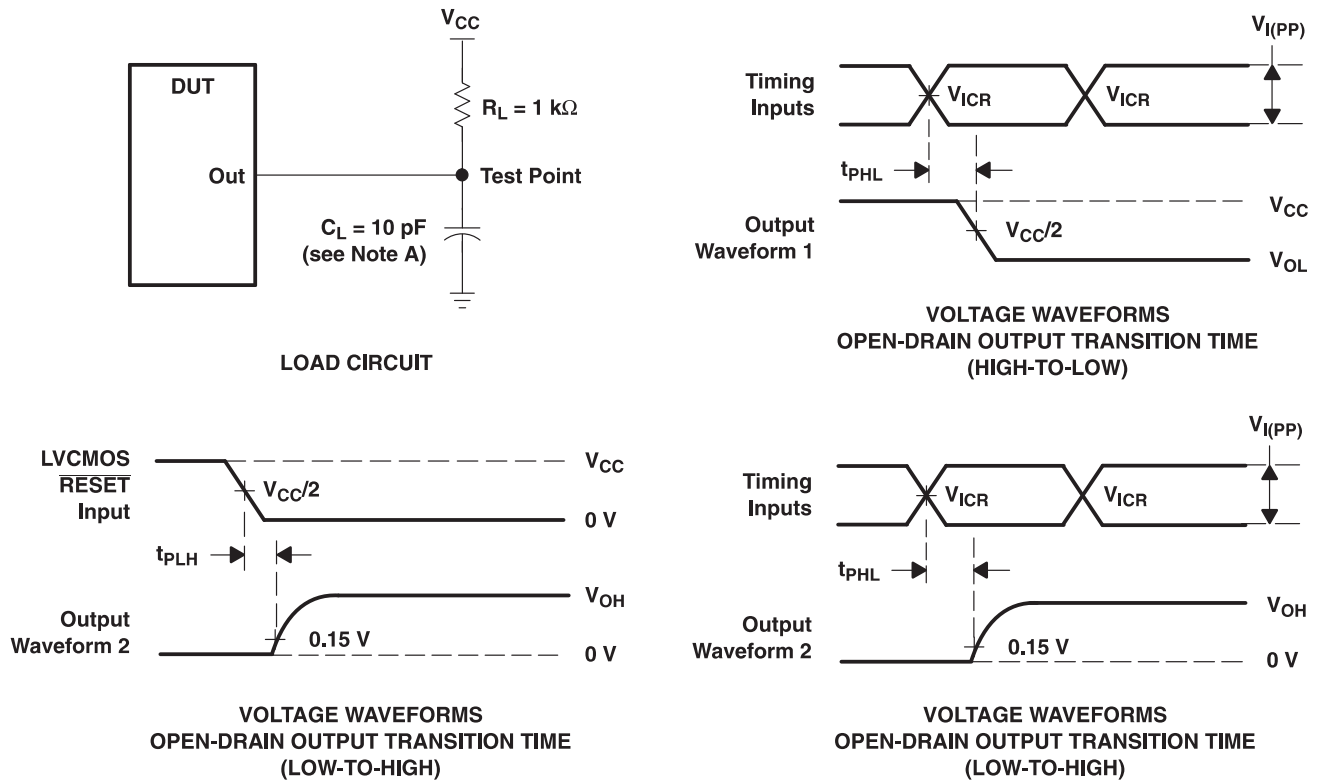

- NOTES:
- A. C_L includes probe and jig capacitance.
 - B. All input pulses are supplied by generators having the following characteristics: $PRR \leq 10$ MHz, $Z_O = 50 \Omega$, input slew rate = 1 V/ns $\pm 20\%$ (unless otherwise noted).
 - C. t_{PLH} and t_{PHL} are the same as t_{pd} .

Figure 4. Error Output Load Circuit and Voltage Waveforms

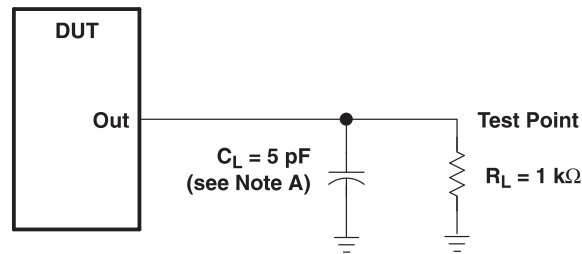

LOAD CIRCUIT

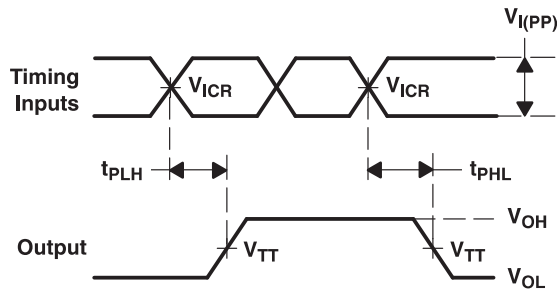

VOLTAGE WAVEFORMS
PROPAGATION DELAY TIMES

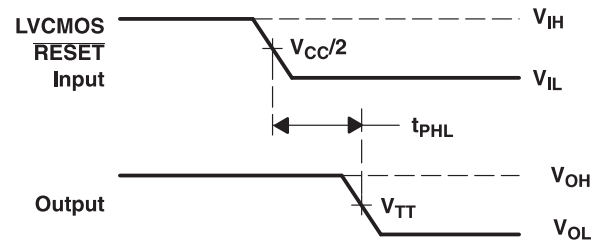

VOLTAGE WAVEFORMS
PROPAGATION DELAY TIMES

- NOTES:
- A. C_L includes probe and jig capacitance.
 - B. All input pulses are supplied by generators having the following characteristics: $PRR \leq 10$ MHz, $Z_O = 50 \Omega$, input slew rate = 1 V/ns $\pm 20\%$ (unless otherwise noted).
 - C. $V_{REF} = V_{TT} = V_{CC}/2$
 - D. $V_{IH} = V_{REF} + 250$ mV (ac voltage levels) for differential inputs. $V_{IH} = V_{CC}$ for LVC MOS input.
 - E. $V_{IL} = V_{REF} - 250$ mV (ac voltage levels) for differential inputs. $V_{IL} = GND$ for LVC MOS input.
 - F. $V_{I(PP)} = 600$ mV
 - G. t_{PLH} and t_{PHL} are the same as t_{pd} .

Figure 5. Partial-Parity-Out Load Circuit and Voltage Waveforms

APPLICATION INFORMATION

The typical values below are for standard raw cards. Test equipment used was the JEDEC register validation board using pattern 0x43, 0x4F, and 0x5A.

Table 1. Raw Card Values ⁽¹⁾ ⁽²⁾

RAW CARD	t_{pdms}		OVERSHOOT
	MIN	MAX	
A/F (@800 MBit/s)	1.0 ns	1.5 ns	590 mV
B/G (@800 MBit/s)	1.2 ns	1.9 ns	590 mV
C/H (@800 MBit/s)	1.2 ns	1.9 ns	730 mV
J (@667 MBit/s)	1.3 ns	2.0 ns	340 mV

- (1) All values are valid under nominal conditions and minimum/maximum of typical signals on one typical DIMM.
 (2) Measurements include all jitter and ISI effects.

74SSTUB32866A Used as a Single Device in the 1:1 Register Configuration; C0 = 0, C1 = 0

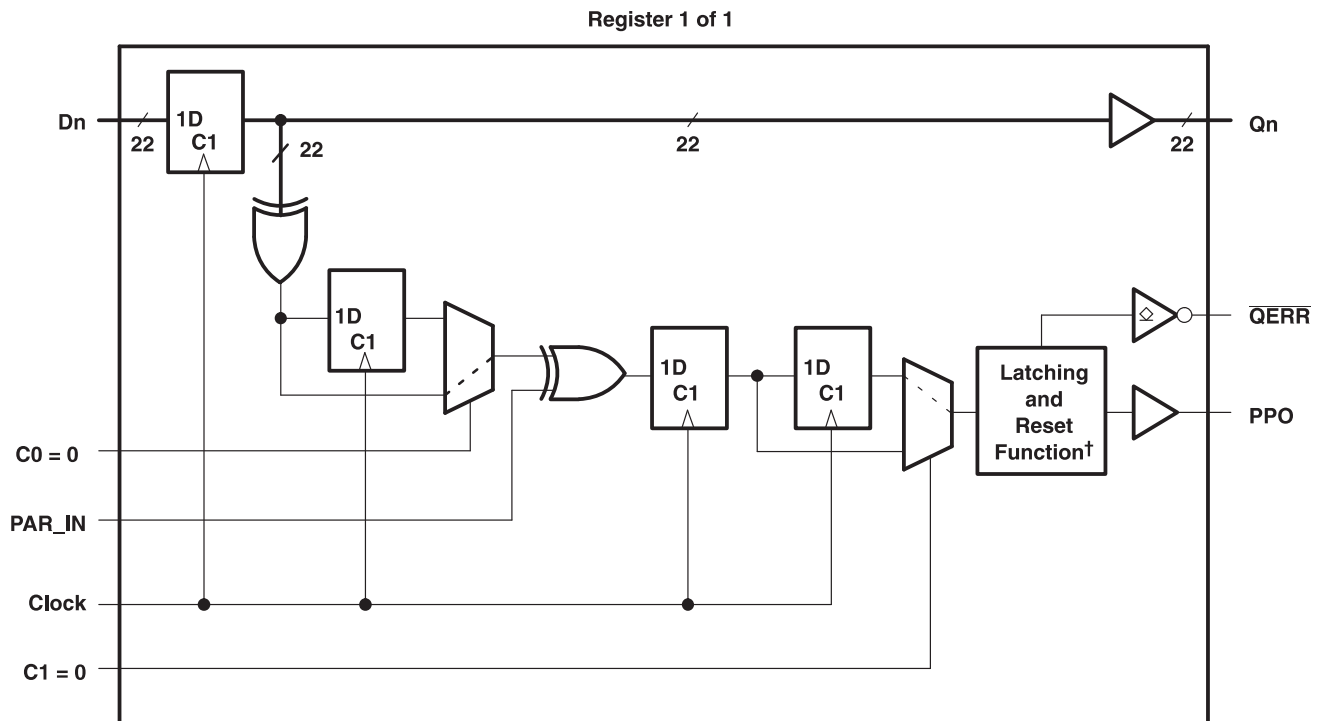

† This function holds the error for two cycles. For details, see the parity logic diagram.

Timing Diagram for 74SSTUB32866A Used as a Single Device; C0 = 0, C1 = 0 ($\overline{\text{RESET}}$ Switches From L to H)

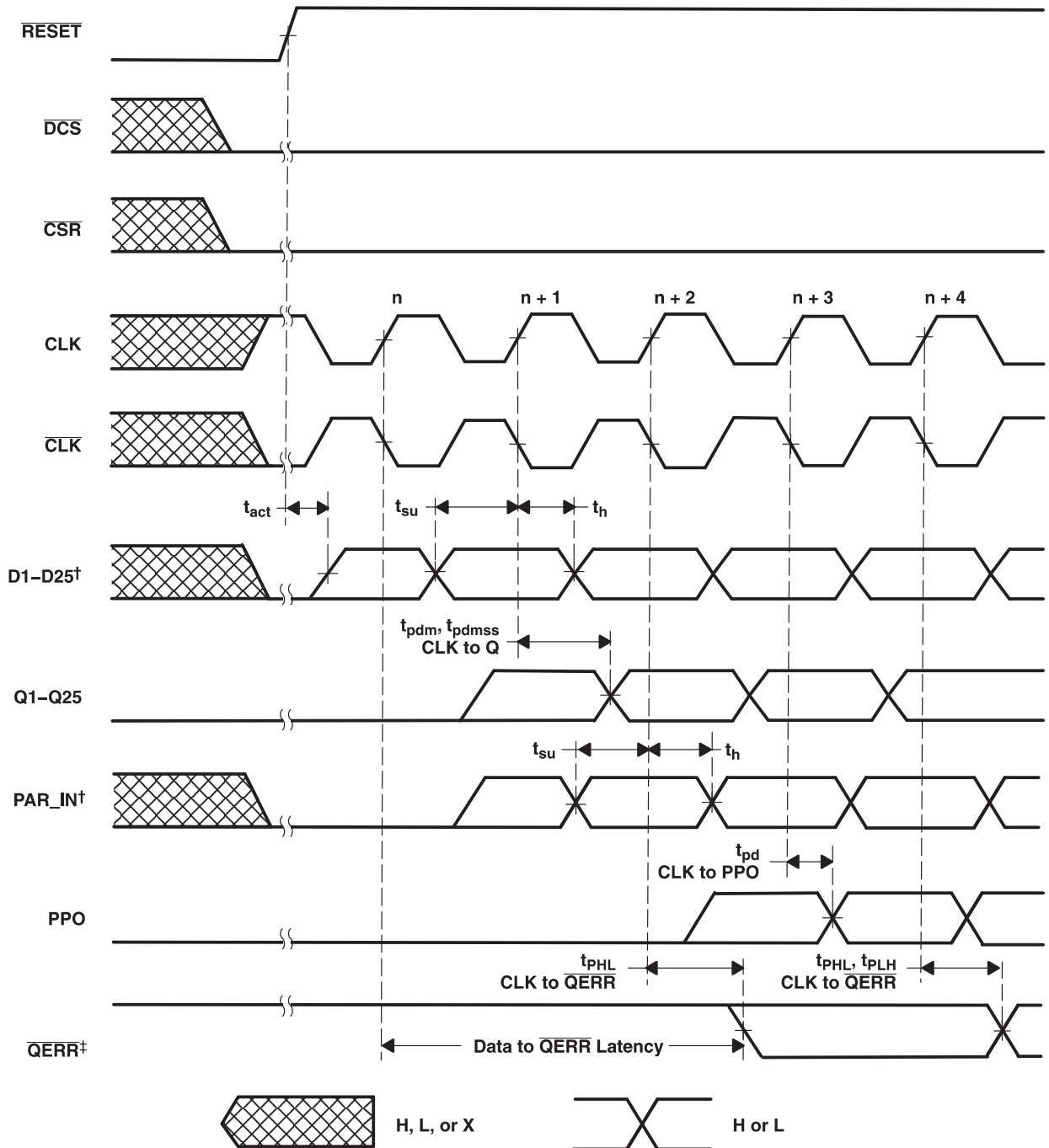

† After $\overline{\text{RESET}}$ is switched from low to high, all data and PAR_IN input signals must be set and held low for a minimum time of t_{act} max, to avoid false error.

‡ If the data is clocked in on the n clock pulse, the $\overline{\text{QERR}}$ output signal will be generated on the $n + 2$ clock pulse, and it will be valid on the $n + 3$ clock pulse.

Timing Diagram for 74SSTUB32866A Used as a Single Device; C0 = 0, C1 = 0 ($\overline{\text{RESET}} = \text{H}$)

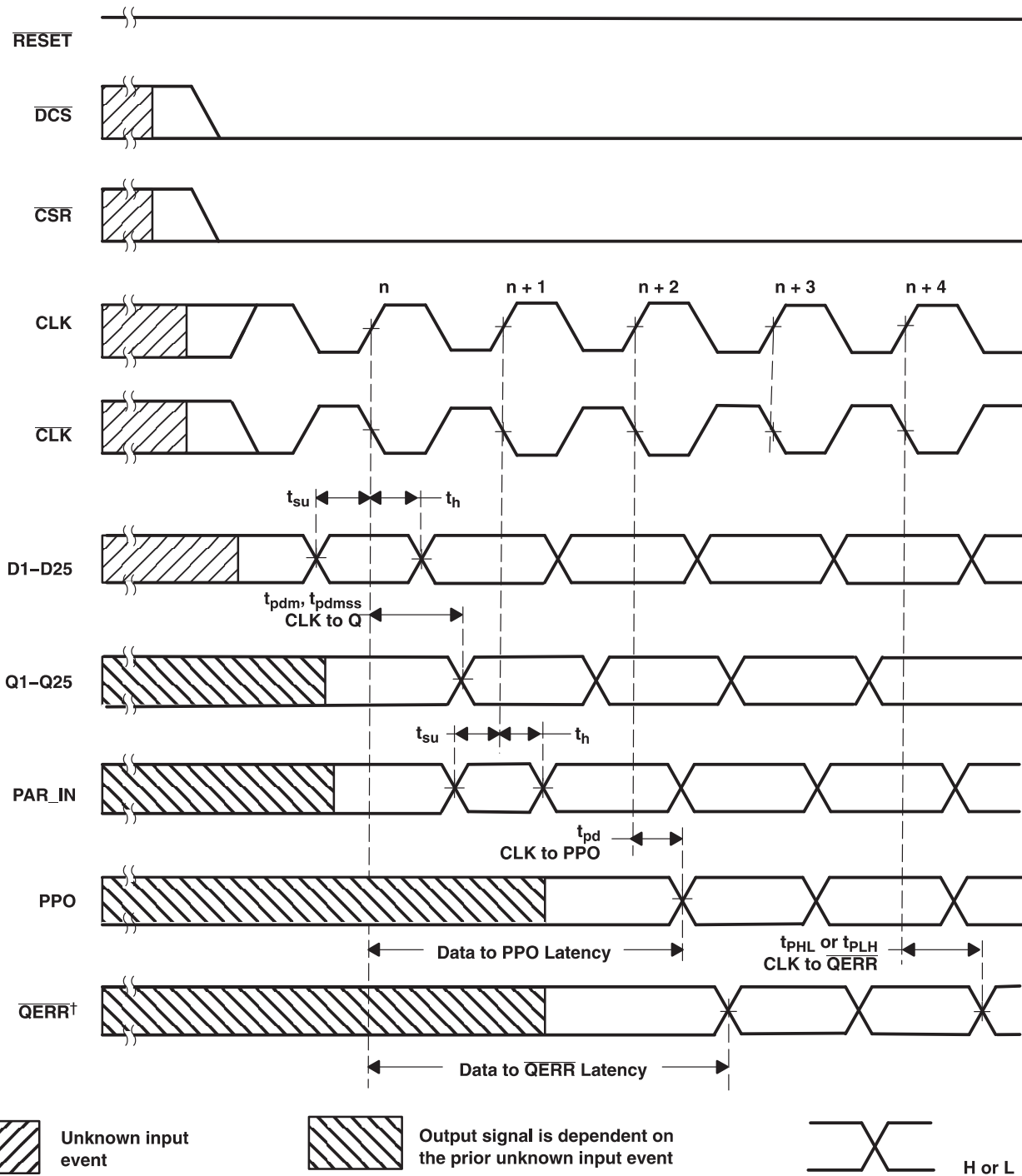

† If the data is clocked in on the n clock pulse, the $\overline{\text{QERR}}$ output signal will be generated on the n + 2 clock pulse, and it will be valid on n + 3 clock pulse. If an error occurs and the $\overline{\text{QERR}}$ output is driven low, it stays latched low for a minimum of two clock cycles or until $\overline{\text{RESET}}$ is driven low.

Timing Diagram for 74SSTUB32866A Used as a Single Device; C0 = 0, C1 = 0 ($\overline{\text{RESET}}$ Switches From = H to L)

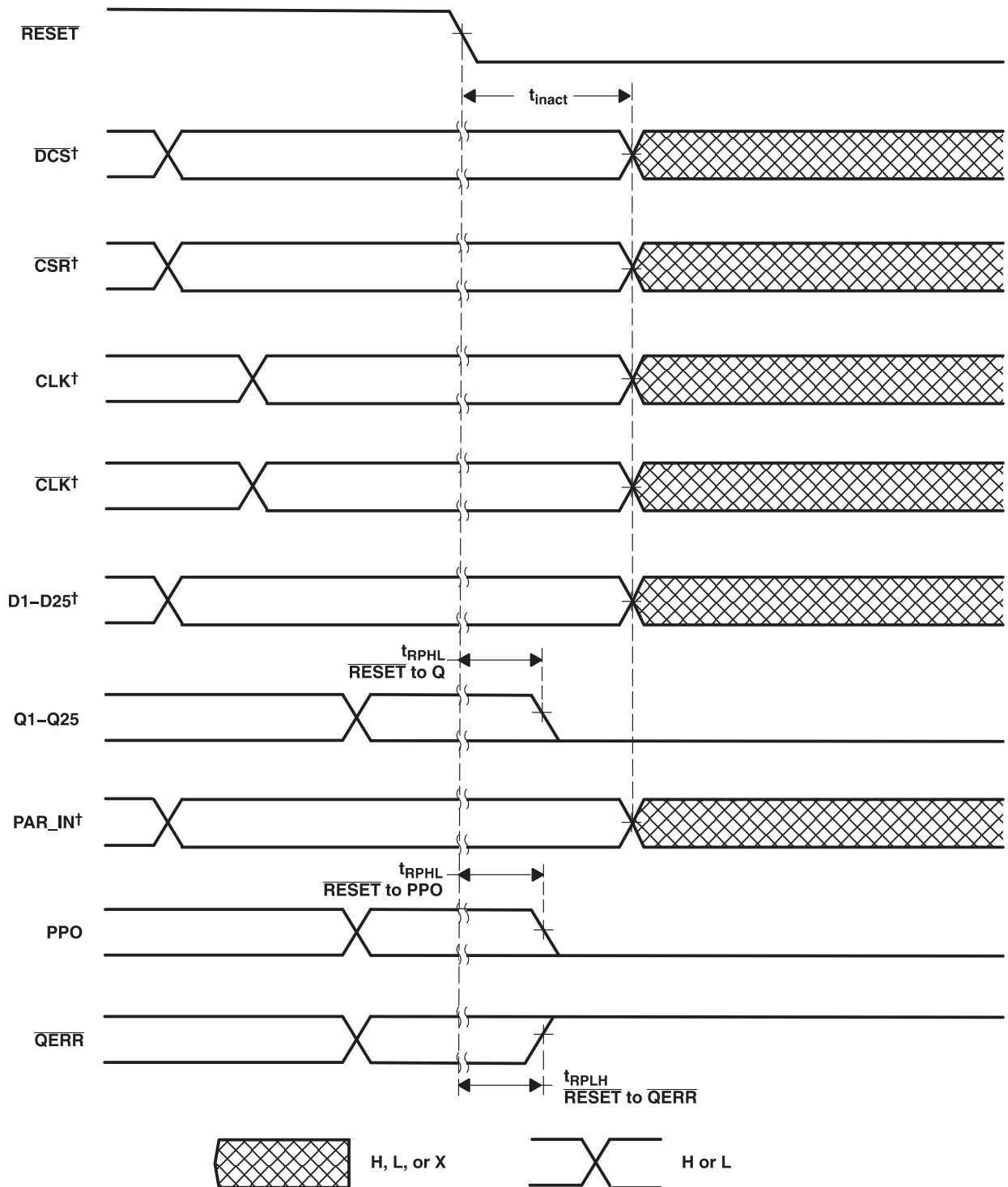

† After $\overline{\text{RESET}}$ is switched from high to low, all data and clock input signals must be held at valid logic levels (not floating) for a minimum time of t_{inact} max.

74SSTUB32866A Used in Pair in the 1:2 Register Configuration

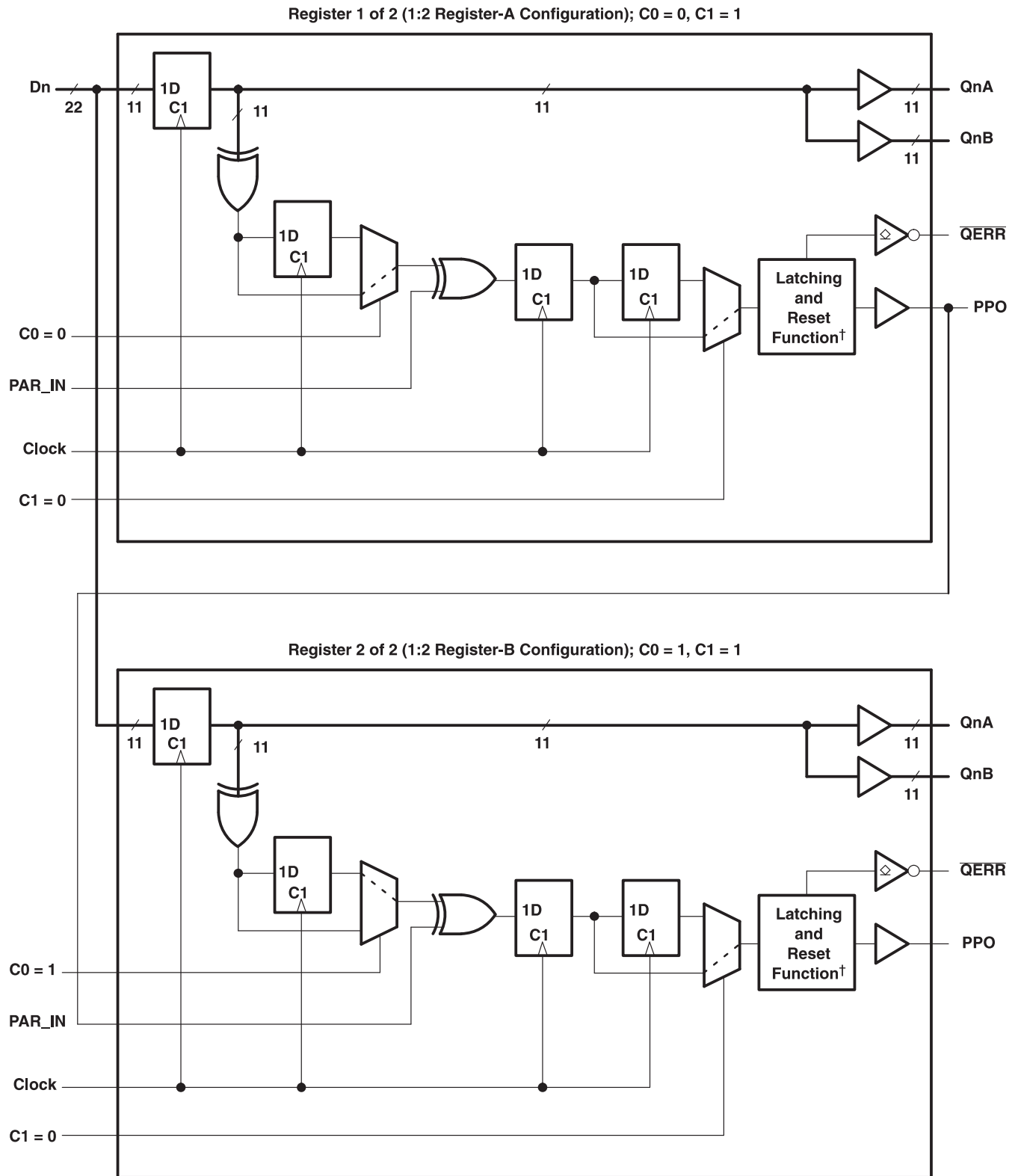

† This function holds the error for two cycles. For details, see the parity logic diagram.

Timing Diagram for the First 74SSTUB32866A (1:2 Register-A Configuration) Device Used in Pair; C0 = 0, C1 = 1 (RESET Switches From L to H)

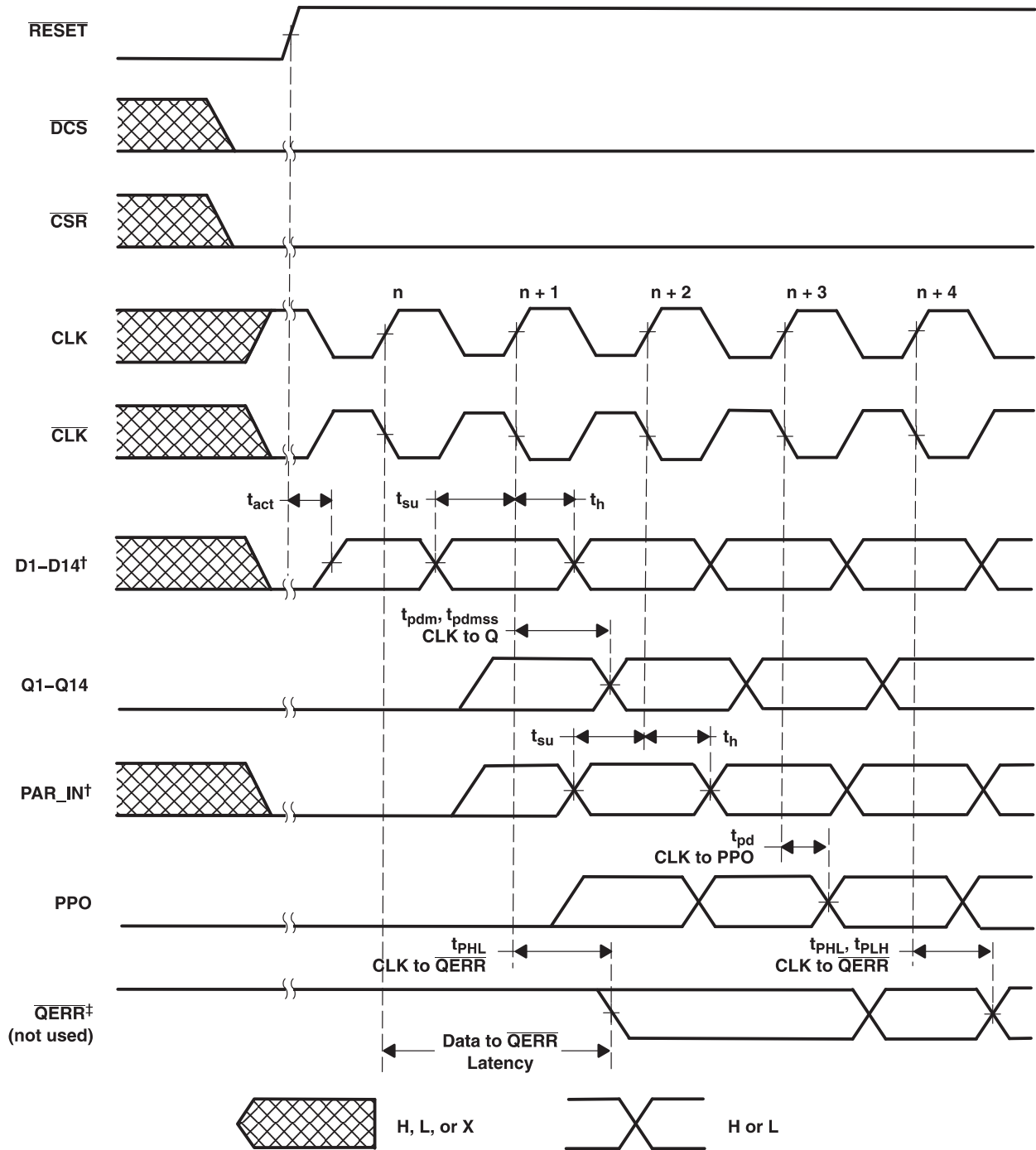

† After \overline{RESET} is switched from low to high, all data and $\overline{PAR_IN}$ input signals must be set and held low for a minimum time of t_{act} max, to avoid false error.
 ‡ If the data is clocked in on the n clock pulse, the \overline{QERR} output signal will be generated on the n + 1 clock pulse, and it will be valid on the n + 2 clock pulse.

Timing Diagram for the First 74SSTUB32866A (1:2 Register-A Configuration) Device Used in Pair; C0 = 0, C1 = 1 (RESET = H)

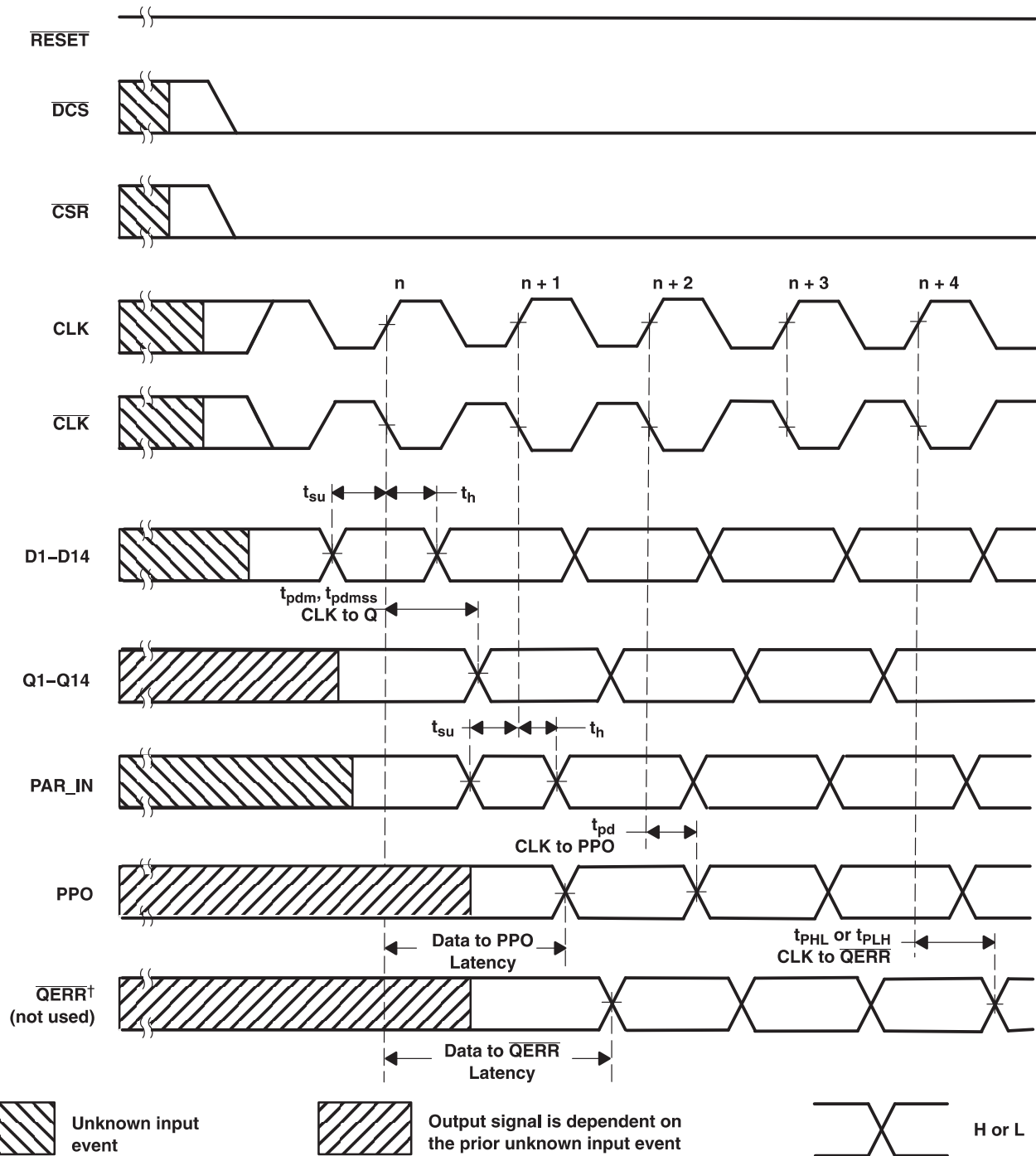

† If the data is clocked in on the n clock pulse, the \overline{QERR} output signal will be generated on the $n + 1$ clock pulse, and it will be valid on $n + 2$ clock pulse. If an error occurs and the \overline{QERR} output is driven low, it stays latched low for a minimum of two clock cycles or until RESET is driven low.

Timing Diagram for the First 74SSTUB32866A (1:2 Register-A Configuration) Device Used in Pair; C0 = 0, C1 = 1 (RESET = Switches From H to L)

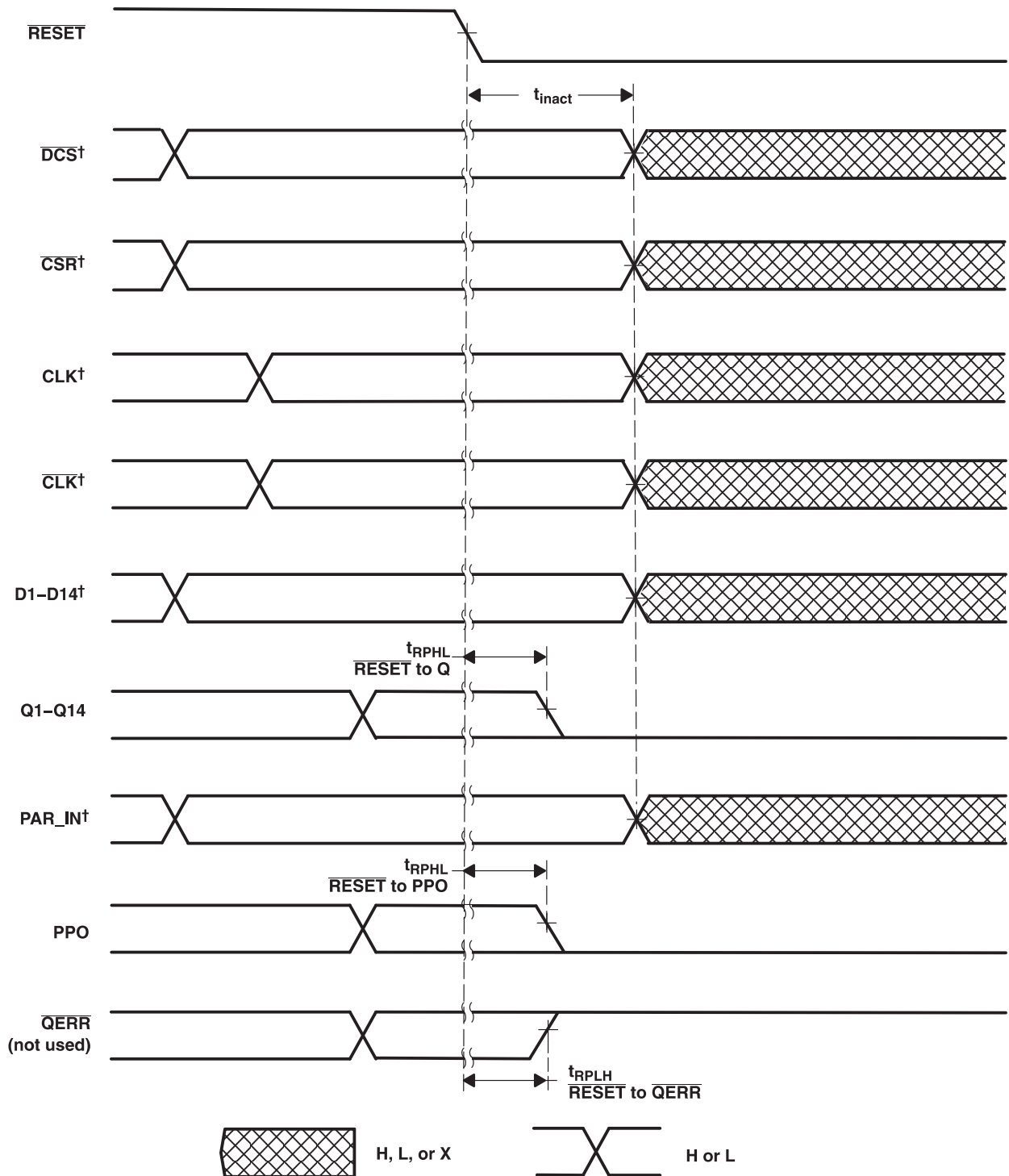

† After RESET is switched from high to low, all data and clock input signals must be held at valid logic levels (not floating) for a minimum time of t_{inact} max.

Timing Diagram for the Second 74SSTUB32866A (1:2 Register-B Configuration) Device Used in Pair; C0 = 1, C1 = 1 (RESET = Switches From L to H)

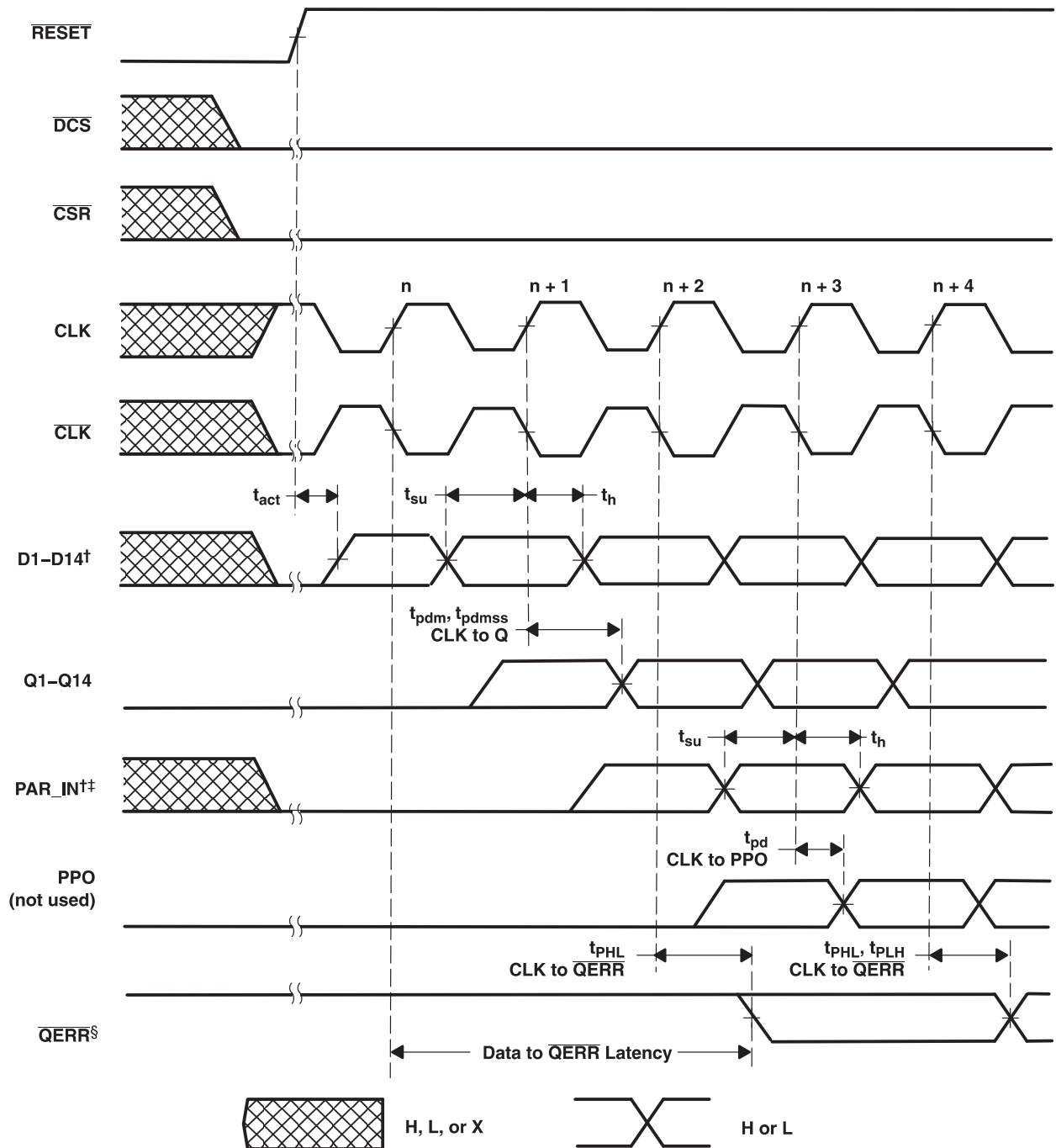

† After RESET is switched from low to high, all data and PAR_IN input signals must be set and held low for a minimum time of t_{act} max, to avoid false error.

‡ PAR_IN is driven from PPO of the first SN74SSTUB32866 device.

§ If the data is clocked in on the n clock pulse, the QERR output signal will be generated on the n + 2 clock pulse, and it will be valid on the n + 3 clock pulse.

Timing Diagram for the Second 74SSTUB32866A (1:2 Register-B Configuration) Device Used in Pair; C0 = 1, C1 = 1 (RESET = H)

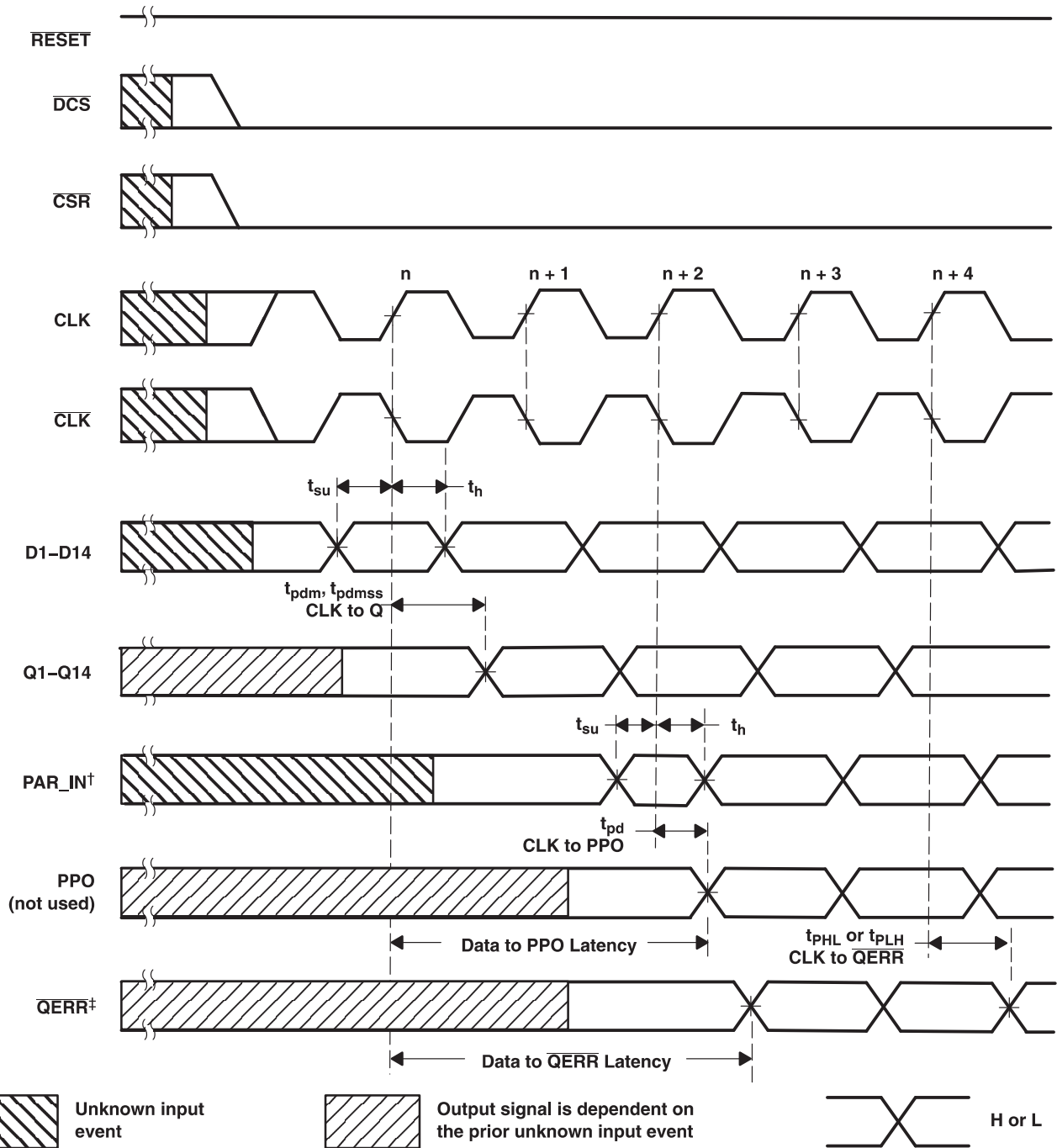

† PAR_IN is driven from PPO of the first SN74SSTUB32866 device.

‡ If the data is clocked in on the n clock pulse, the QERR output signal will be generated on the n + 2 clock pulse, and it will be valid on n + 3 clock pulse. If an error occurs and the QERR output is driven low, it stays latched low for a minimum of two clock cycles or until RESET is driven low.

Timing Diagram for the Second 74SSTUB32866A (1:2 Register-B Configuration) Device Used in Pair; C0 = 1, C1 = 1 (RESET = Switches From H to L)

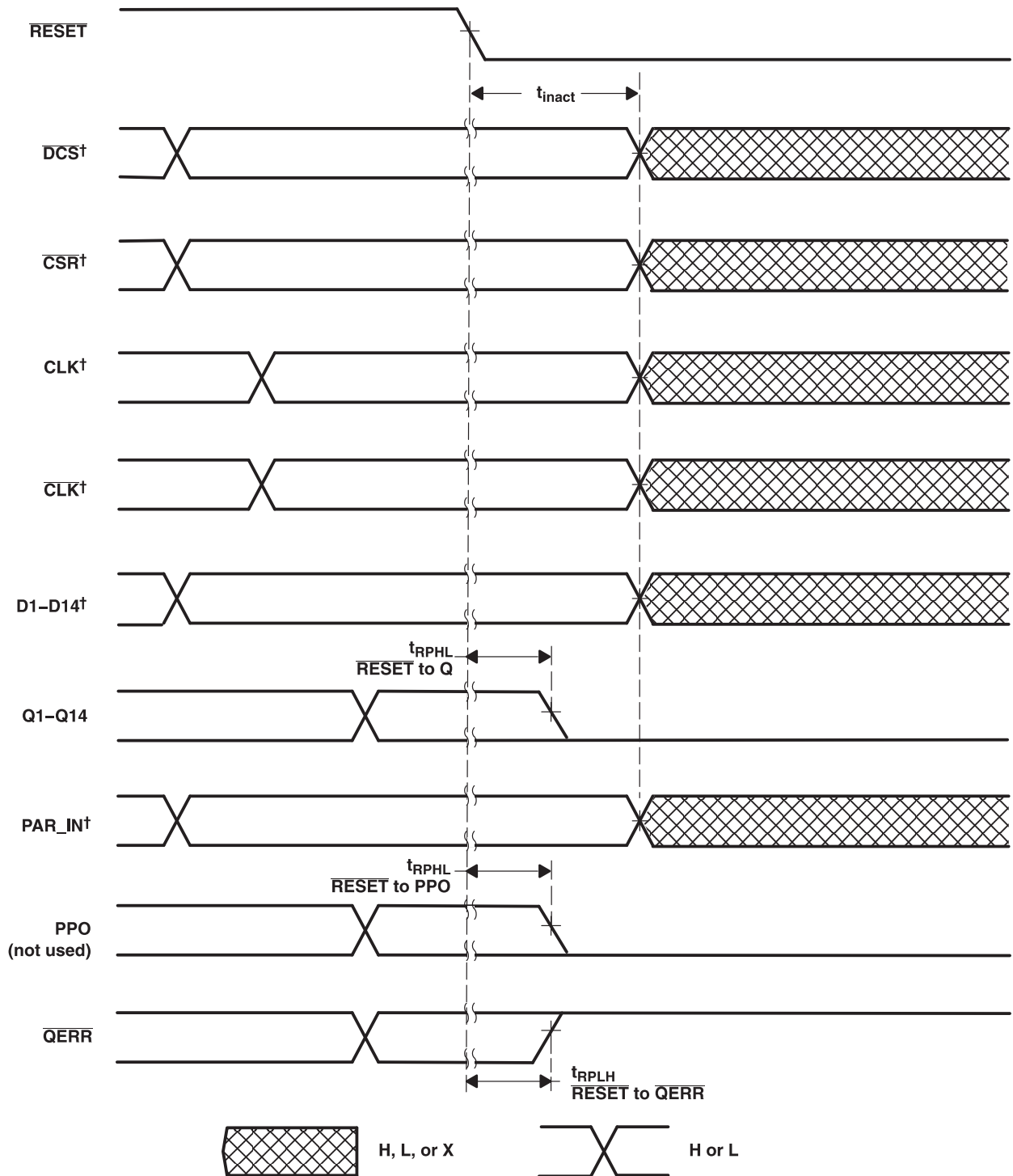

† After RESET is switched from high to low, all data and clock input signals must be held at valid logic levels (not floating) for a minimum time of t_{inact} max.

PACKAGING INFORMATION

Orderable Device	Status ⁽¹⁾	Package Type	Package Drawing	Pins	Package Qty	Eco Plan ⁽²⁾	Lead/Ball Finish	MSL Peak Temp ⁽³⁾
74SSTUB32866AZKER	ACTIVE	LFBGA	ZKE	96	1000	Green (RoHS & no Sb/Br)	SNAGCU	Level-3-260C-168 HR

⁽¹⁾ The marketing status values are defined as follows:

ACTIVE: Product device recommended for new designs.

LIFEBUY: TI has announced that the device will be discontinued, and a lifetime-buy period is in effect.

NRND: Not recommended for new designs. Device is in production to support existing customers, but TI does not recommend using this part in a new design.

PREVIEW: Device has been announced but is not in production. Samples may or may not be available.

OBSOLETE: TI has discontinued the production of the device.

⁽²⁾ Eco Plan - The planned eco-friendly classification: Pb-Free (RoHS), Pb-Free (RoHS Exempt), or Green (RoHS & no Sb/Br) - please check <http://www.ti.com/productcontent> for the latest availability information and additional product content details.

TBD: The Pb-Free/Green conversion plan has not been defined.

Pb-Free (RoHS): TI's terms "Lead-Free" or "Pb-Free" mean semiconductor products that are compatible with the current RoHS requirements for all 6 substances, including the requirement that lead not exceed 0.1% by weight in homogeneous materials. Where designed to be soldered at high temperatures, TI Pb-Free products are suitable for use in specified lead-free processes.

Pb-Free (RoHS Exempt): This component has a RoHS exemption for either 1) lead-based flip-chip solder bumps used between the die and package, or 2) lead-based die adhesive used between the die and leadframe. The component is otherwise considered Pb-Free (RoHS compatible) as defined above.

Green (RoHS & no Sb/Br): TI defines "Green" to mean Pb-Free (RoHS compatible), and free of Bromine (Br) and Antimony (Sb) based flame retardants (Br or Sb do not exceed 0.1% by weight in homogeneous material)

⁽³⁾ MSL, Peak Temp. -- The Moisture Sensitivity Level rating according to the JEDEC industry standard classifications, and peak solder temperature.

Important Information and Disclaimer:The information provided on this page represents TI's knowledge and belief as of the date that it is provided. TI bases its knowledge and belief on information provided by third parties, and makes no representation or warranty as to the accuracy of such information. Efforts are underway to better integrate information from third parties. TI has taken and continues to take reasonable steps to provide representative and accurate information but may not have conducted destructive testing or chemical analysis on incoming materials and chemicals. TI and TI suppliers consider certain information to be proprietary, and thus CAS numbers and other limited information may not be available for release.

In no event shall TI's liability arising out of such information exceed the total purchase price of the TI part(s) at issue in this document sold by TI to Customer on an annual basis.

TAPE AND REEL INFORMATION

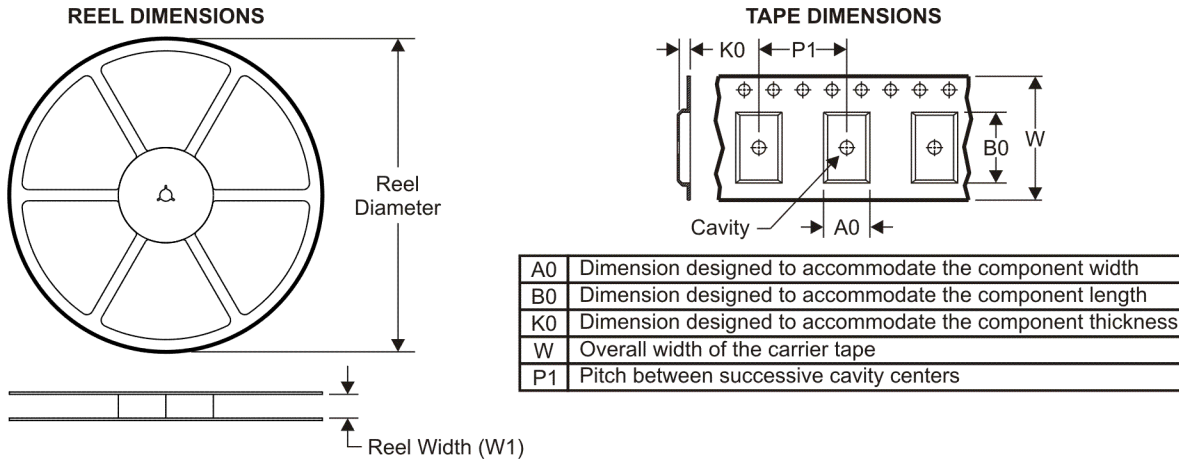

QUADRANT ASSIGNMENTS FOR PIN 1 ORIENTATION IN TAPE

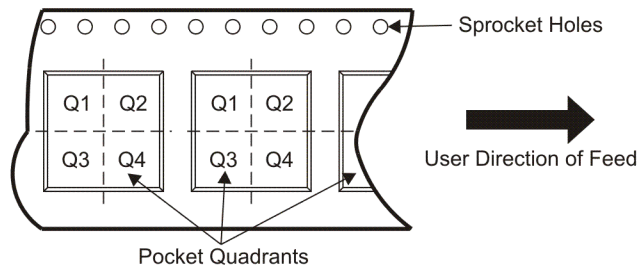

*All dimensions are nominal

Device	Package Type	Package Drawing	Pins	SPQ	Reel Diameter (mm)	Reel Width W1 (mm)	A0 (mm)	B0 (mm)	K0 (mm)	P1 (mm)	W (mm)	Pin1 Quadrant
74SSTUB32866AZKER	LFBGA	ZKE	96	1000	330.0	24.4	5.7	13.7	2.0	8.0	24.0	Q1

TAPE AND REEL BOX DIMENSIONS

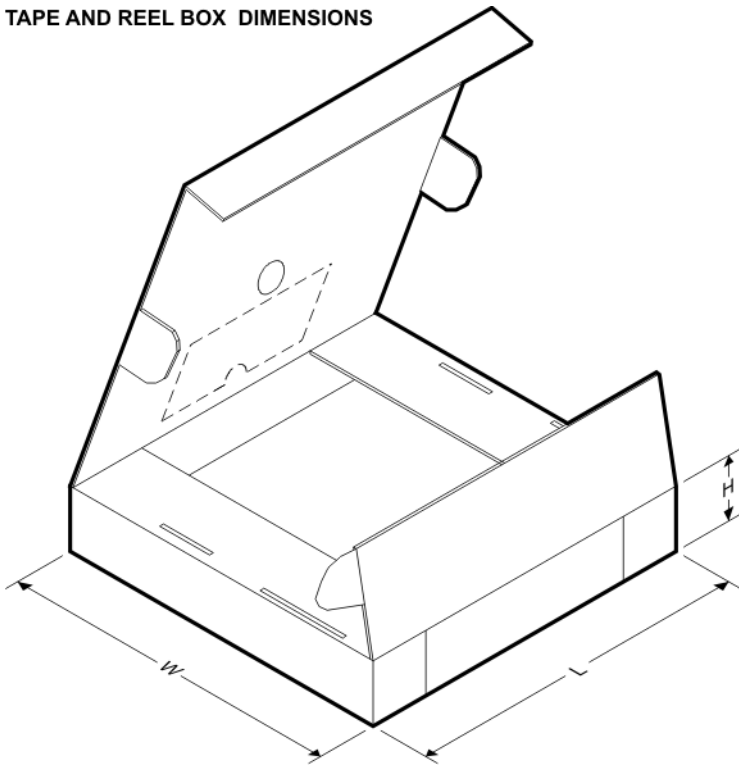

*All dimensions are nominal

Device	Package Type	Package Drawing	Pins	SPQ	Length (mm)	Width (mm)	Height (mm)
74SSTUB32866AZKER	LFBGA	ZKE	96	1000	333.2	345.9	31.8

ZKE (R-PBGA-N96)

PLASTIC BALL GRID ARRAY

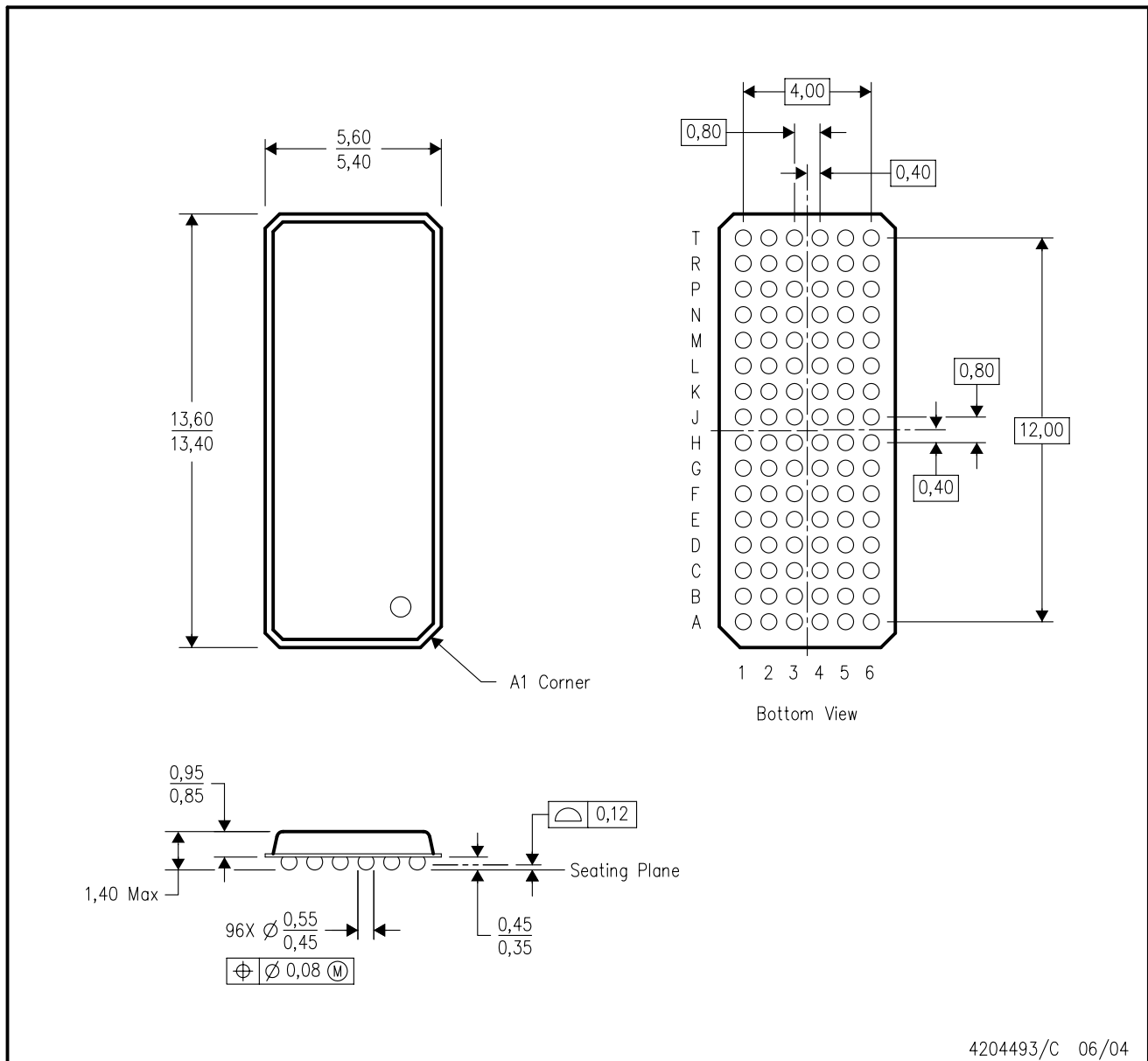

- NOTES:
- A. All linear dimensions are in millimeters.
 - B. This drawing is subject to change without notice.
 - C. Falls within JEDEC MO-205 variation CC.
 - D. This package is lead-free. Refer to the 96 GKE package (drawing 4188953) for tin-lead (SnPb).

IMPORTANT NOTICE

Texas Instruments Incorporated and its subsidiaries (TI) reserve the right to make corrections, modifications, enhancements, improvements, and other changes to its products and services at any time and to discontinue any product or service without notice. Customers should obtain the latest relevant information before placing orders and should verify that such information is current and complete. All products are sold subject to TI's terms and conditions of sale supplied at the time of order acknowledgment.

TI warrants performance of its hardware products to the specifications applicable at the time of sale in accordance with TI's standard warranty. Testing and other quality control techniques are used to the extent TI deems necessary to support this warranty. Except where mandated by government requirements, testing of all parameters of each product is not necessarily performed.

TI assumes no liability for applications assistance or customer product design. Customers are responsible for their products and applications using TI components. To minimize the risks associated with customer products and applications, customers should provide adequate design and operating safeguards.

TI does not warrant or represent that any license, either express or implied, is granted under any TI patent right, copyright, mask work right, or other TI intellectual property right relating to any combination, machine, or process in which TI products or services are used. Information published by TI regarding third-party products or services does not constitute a license from TI to use such products or services or a warranty or endorsement thereof. Use of such information may require a license from a third party under the patents or other intellectual property of the third party, or a license from TI under the patents or other intellectual property of TI.

Reproduction of TI information in TI data books or data sheets is permissible only if reproduction is without alteration and is accompanied by all associated warranties, conditions, limitations, and notices. Reproduction of this information with alteration is an unfair and deceptive business practice. TI is not responsible or liable for such altered documentation. Information of third parties may be subject to additional restrictions.

Resale of TI products or services with statements different from or beyond the parameters stated by TI for that product or service voids all express and any implied warranties for the associated TI product or service and is an unfair and deceptive business practice. TI is not responsible or liable for any such statements.

TI products are not authorized for use in safety-critical applications (such as life support) where a failure of the TI product would reasonably be expected to cause severe personal injury or death, unless officers of the parties have executed an agreement specifically governing such use. Buyers represent that they have all necessary expertise in the safety and regulatory ramifications of their applications, and acknowledge and agree that they are solely responsible for all legal, regulatory and safety-related requirements concerning their products and any use of TI products in such safety-critical applications, notwithstanding any applications-related information or support that may be provided by TI. Further, Buyers must fully indemnify TI and its representatives against any damages arising out of the use of TI products in such safety-critical applications.

TI products are neither designed nor intended for use in military/aerospace applications or environments unless the TI products are specifically designated by TI as military-grade or "enhanced plastic." Only products designated by TI as military-grade meet military specifications. Buyers acknowledge and agree that any such use of TI products which TI has not designated as military-grade is solely at the Buyer's risk, and that they are solely responsible for compliance with all legal and regulatory requirements in connection with such use.

TI products are neither designed nor intended for use in automotive applications or environments unless the specific TI products are designated by TI as compliant with ISO/TS 16949 requirements. Buyers acknowledge and agree that, if they use any non-designated products in automotive applications, TI will not be responsible for any failure to meet such requirements.

Following are URLs where you can obtain information on other Texas Instruments products and application solutions:

Products

Amplifiers	amplifier.ti.com
Data Converters	dataconverter.ti.com
DSP	dsp.ti.com
Clocks and Timers	www.ti.com/clocks
Interface	interface.ti.com
Logic	logic.ti.com
Power Mgmt	power.ti.com
Microcontrollers	microcontroller.ti.com
RFID	www.ti-rfid.com
RF/IF and ZigBee® Solutions	www.ti.com/lprf

Applications

Audio	www.ti.com/audio
Automotive	www.ti.com/automotive
Broadband	www.ti.com/broadband
Digital Control	www.ti.com/digitalcontrol
Medical	www.ti.com/medical
Military	www.ti.com/military
Optical Networking	www.ti.com/opticalnetwork
Security	www.ti.com/security
Telephony	www.ti.com/telephony
Video & Imaging	www.ti.com/video
Wireless	www.ti.com/wireless

Mailing Address: Texas Instruments, Post Office Box 655303, Dallas, Texas 75265
Copyright © 2008, Texas Instruments Incorporated