



Low-Power, Rail-to-Rail Output, 16-Bit Serial Input DIGITAL-TO-ANALOG CONVERTER

FEATURES

- **microPower OPERATION:** 250 μ A at 5V
- **POWER-ON RESET TO ZERO**
- **POWER SUPPLY:** +2.7V to +5.5V
- **ENSURED MONOTONIC BY DESIGN**
- **SETTLING TIME:** 10 μ s to \pm 0.003 FSR
- **LOW-POWER SERIAL INTERFACE WITH SCHMITT-TRIGGERED INPUTS**
- **ON-CHIP OUTPUT BUFFER AMPLIFIER, RAIL-TO-RAIL OPERATION**
- **SYNC INTERRUPT FACILITY**
- **PACKAGES:** MSOP-8 and 3x3 SON-8 (same size as QFN)

APPLICATIONS

- **PROCESS CONTROL**
- **DATA ACQUISITION SYSTEMS**
- **CLOSED-LOOP SERVO-CONTROL**
- **PC PERIPHERALS**
- **PORTABLE INSTRUMENTATION**
- **PROGRAMMABLE ATTENUATION**

DESCRIPTION

The DAC8531 is a low-power, single, 16-bit buffered voltage output Digital-to-Analog Converter (DAC). Its on-chip precision output amplifier allows rail-to-rail output swing to be achieved. The DAC8531 uses a versatile three-wire serial interface that operates at clock rates up to 30MHz and is compatible with standard SPI™, QSPI™, Microwire™, and Digital Signal Processor (DSP) interfaces.

The DAC8531 requires an external reference voltage to set the output range of the DAC. The DAC8531 incorporates a power-on reset circuit that ensures that the DAC output powers up at 0V and remains there until a valid write takes place to the device. The DAC8531 contains a power-down feature, accessed over the serial interface, that reduces the current consumption of the device to 200nA at 5V.

The low power consumption of this part in normal operation makes it ideally suited to portable battery-operated equipment. The power consumption is 2mW at 5V reducing to 1 μ W in power-down mode.

The DAC8531 is available in both MSOP-8 and 3x3 SON-8 (same size as QFN) packages.

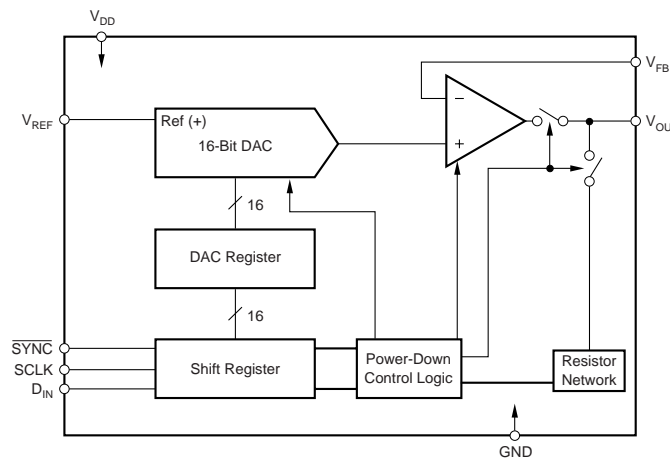

Please be aware that an important notice concerning availability, standard warranty, and use in critical applications of Texas Instruments semiconductor products and disclaimers thereto appears at the end of this data sheet.

All trademarks are the property of their respective owners.

PRODUCTION DATA information is current as of publication date. Products conform to specifications per the terms of Texas Instruments standard warranty. Production processing does not necessarily include testing of all parameters.



ABSOLUTE MAXIMUM RATINGS⁽¹⁾

V _{DD} to GND	-0.3V to +6V
Digital Input Voltage to GND	-0.3V to +V _{DD} + 0.3V
V _{OUT} to GND	-0.3V to +V _{DD} + 0.3V
Operating Temperature Range	-40°C to +105°C
Storage Temperature Range	-65°C to +150°C
Junction Temperature Range (T _J max)	+150°C
Power Dissipation	(T _J max - T _A)/θ _{JA}
θ _{JA} Thermal Impedance	206°C/W
θ _{JC} Thermal Impedance	44°C/W
Lead Temperature, Soldering:	
Vapor Phase (60s)	+215°C
Infrared (15s)	+220°C

NOTE: (1) Stresses above those listed under "Absolute Maximum Ratings" may cause permanent damage to the device. Exposure to absolute maximum conditions for extended periods may affect device reliability.



ELECTROSTATIC DISCHARGE SENSITIVITY

This integrated circuit can be damaged by ESD. Texas Instruments recommends that all integrated circuits be handled with appropriate precautions. Failure to observe proper handling and installation procedures can cause damage.

ESD damage can range from subtle performance degradation to complete device failure. Precision integrated circuits may be more susceptible to damage because very small parametric changes could cause the device not to meet its published specifications.

PACKAGE/ORDERING INFORMATION

PRODUCT	MINIMUM RELATIVE ACCURACY (LSB)	DIFFERENTIAL NONLINEARITY (LSB)	PACKAGE-LEAD	PACKAGE DESIGNATOR ⁽¹⁾	SPECIFICATION TEMPERATURE RANGE	PACKAGE MARKING	ORDERING NUMBER	TRANSPORT MEDIA, QUANTITY
DAC8531E "	±64 "	±1 "	MSOP-8 "	DGK "	-40°C to +105°C "	D31 "	DAC8531E/250 DAC8531E/2K5	Tape and Reel, 250 Tape and Reel, 2500
DAC8531I DAC8531I	±64 "	±1 "	SON-8 "	DRB "	-40°C to +105°C "	D31 "	DAC8531IDRBT DAC8531IDRBR	Tape and Reel, 250 Tape and Reel, 2500

NOTE: (1) For the most current specifications and package information, refer to our web site at www.ti.com.

ELECTRICAL CHARACTERISTICS

V_{DD} = +2.7V to +5.5V. -40°C to +105°C, unless otherwise specified.

PARAMETER	CONDITIONS	DAC8531E			UNITS
		MIN	TYP	MAX	
STATIC PERFORMANCE⁽¹⁾					
Resolution		16			Bits
Relative Accuracy				±0.098	% of FSR
Differential Nonlinearity	Ensured Monotonic by Design			±1	LSB
Zero Code Error	All Zeroes Loaded to DAC Register		+5	+20	mV
Full-Scale Error	All Ones Loaded to DAC Register		-0.15	-1.25	% of FSR
Gain Error				±1.25	% of FSR
Zero Code Error Drift			±20		μV/°C
Gain Temperature Coefficient			±5		ppm of FSR/°C
OUTPUT CHARACTERISTICS⁽²⁾					
Output Voltage Range		0		V _{REF}	V
Output Voltage Settling Time	To ±0.003% FSR 0200 _H to FD00 _H R _L = 2kΩ; 0pF < C _L < 200pF R _L = 2kΩ; C _L = 500pF		8	10	μs
Slew Rate			12		μs
Capacitive Load Stability	R _L = ∞ R _L = 2kΩ		1 470		V/μs pF
Code Change Glitch Impulse	1LSB Change Around Major Carry		1000		pF
Digital Feedthrough			20		nV-s
DC Output Impedance			0.5		nV-s
Short-Circuit Current			1		Ω
Power-Up Time	V _{DD} = +5V V _{DD} = +3V Coming Out of Power-Down Mode		50 20		mA mA
	V _{DD} = +5V Coming Out of Power-Down Mode		2.5		μs
	V _{DD} = +3V		5		μs
REFERENCE INPUT					
Reference Current	V _{REF} = V _{DD} = +5V V _{REF} = V _{DD} = +3.6V		35 20	45 30	μA μA
Reference Input Range		0		V _{DD}	V
Reference Input Impedance			150		kΩ

NOTES: (1) Linearity calculated using a reduced code range of 485 to 64714; output unloaded. (2) Ensured by design and characterization, not production tested.

ELECTRICAL CHARACTERISTICS (Cont.)

$V_{DD} = +2.7V$ to $+5.5V$. $-40^{\circ}C$ to $+105^{\circ}C$, unless otherwise specified.

PARAMETER	CONDITIONS	DAC8531E			UNITS
		MIN	TYP	MAX	
LOGIC INPUTS ⁽²⁾					
Input Current				± 1	μA
$V_{IN,L}$, Input LOW Voltage	$V_{DD} = +5V$			0.8	V
$V_{IN,L}$, Input LOW Voltage	$V_{DD} = +3V$			0.6	V
$V_{IN,H}$, Input HIGH Voltage	$V_{DD} = +5V$	2.4			V
$V_{IN,H}$, Input HIGH Voltage	$V_{DD} = +3V$	2.1			V
Pin Capacitance				3	pF
POWER REQUIREMENTS					
V_{DD}		2.7		5.5	V
I_{DD} (normal mode)	DAC Active and Excluding Load Current				
$V_{DD} = +3.6V$ to $+5.5V$	$V_{IH} = V_{DD}$ and $V_{IL} = GND$		250	400	μA
$V_{DD} = +2.7V$ to $+3.6V$	$V_{IH} = V_{DD}$ and $V_{IL} = GND$		240	390	μA
I_{DD} (all power-down modes)					
$V_{DD} = +3.6V$ to $+5.5V$	$V_{IH} = V_{DD}$ and $V_{IL} = GND$		0.2	1	μA
$V_{DD} = +2.7V$ to $+3.6V$	$V_{IH} = V_{DD}$ and $V_{IL} = GND$		0.05	1	μA
POWER EFFICIENCY					
I_{OUT}/I_{DD}	$I_{LOAD} = 2mA$, $V_{DD} = +5V$		89		%
TEMPERATURE RANGE					
Specified Performance		-40		+105	$^{\circ}C$

PIN CONFIGURATIONS

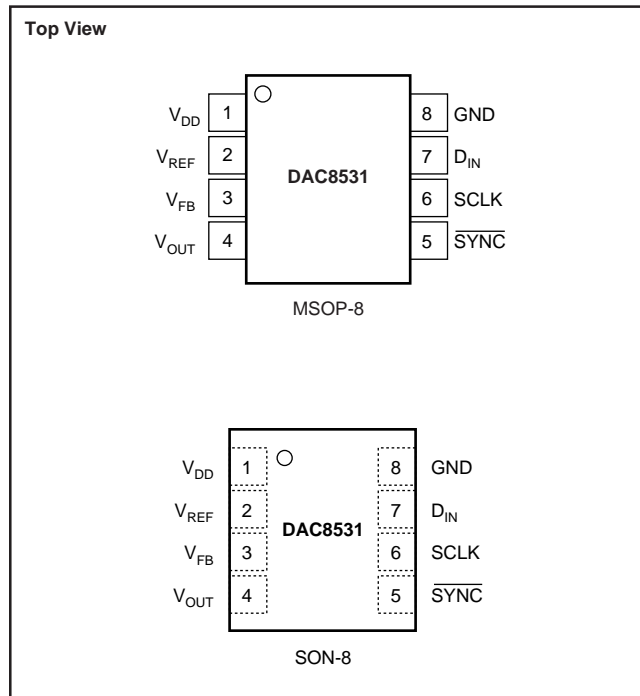

PIN DESCRIPTION

PIN	NAME	DESCRIPTION
1	V_{DD}	Power-Supply Input, $+2.7V$ to $+5.5V$.
2	V_{REF}	Reference Voltage Input
3	V_{FB}	Feedback connection for the output amplifier.
4	V_{OUT}	Analog output voltage from DAC. The output amplifier has rail-to-rail operation.
5	\overline{SYNC}	Level-triggered control input (active LOW). This is the frame synchronization signal for the input data. When \overline{SYNC} goes LOW, it enables the input shift register and data is transferred in on the falling edges of the following clocks. The DAC is updated following the 24th clock cycle unless \overline{SYNC} is taken HIGH before this edge, in which case the rising edge of \overline{SYNC} acts as an interrupt and the write sequence is ignored by the DAC8531.
6	SCLK	Serial Clock Input. Data can be transferred at rates up to 30MHz.
7	D_{IN}	Serial Data Input. Data is clocked into the 24-bit input shift register on the falling edge of the serial clock input.
8	GND	Ground reference point for all circuitry on the part.

TIMING CHARACTERISTICS(1, 2)

$V_{DD} = +2.7V$ to $+5.5V$; all specifications $-40^{\circ}C$ to $+105^{\circ}C$ unless otherwise noted.

PARAMETER	DESCRIPTION	CONDITIONS	DAC8531E			UNITS
			MIN	TYP	MAX	
$t_1^{(3)}$	SCLK Cycle Time	$V_{DD} = 2.7V$ to $3.6V$	50			ns
		$V_{DD} = 3.6V$ to $5.5V$	33			ns
t_2	SCLK HIGH Time	$V_{DD} = 2.7V$ to $3.6V$	13			ns
		$V_{DD} = 3.6V$ to $5.5V$	13			ns
t_3	SCLK LOW Time	$V_{DD} = 2.7V$ to $3.6V$	22.5			ns
		$V_{DD} = 3.6V$ to $5.5V$	13			ns
t_4	\overline{SYNC} to SCLK Rising Edge Setup Time	$V_{DD} = 2.7V$ to $3.6V$	0			ns
		$V_{DD} = 3.6V$ to $5.5V$	0			ns
t_5	Data Setup Time	$V_{DD} = 2.7V$ to $3.6V$	5			ns
		$V_{DD} = 3.6V$ to $5.5V$	5			ns
t_6	Data Hold Time	$V_{DD} = 2.7V$ to $3.6V$	4.5			ns
		$V_{DD} = 3.6V$ to $5.5V$	4.5			ns
t_7	SCLK Falling Edge to \overline{SYNC} Rising Edge	$V_{DD} = 2.7V$ to $3.6V$	0			ns
		$V_{DD} = 3.6V$ to $5.5V$	0			ns
t_8	Minimum \overline{SYNC} HIGH Time	$V_{DD} = 2.7V$ to $3.6V$	50			ns
		$V_{DD} = 3.6V$ to $5.5V$	33			ns

NOTES: (1) All input signals are specified with $t_R = t_F = 5ns$ (10% to 90% of V_{DD}) and timed from a voltage level of $(V_{IL} + V_{IH})/2$. (2) See Serial Write Operation timing diagram, below. (3) Maximum SCLK frequency is 30MHz at $V_{DD} = +3.6V$ to $+5.5V$ and 20MHz at $V_{DD} = +2.7V$ to $+3.6V$.

SERIAL WRITE OPERATION

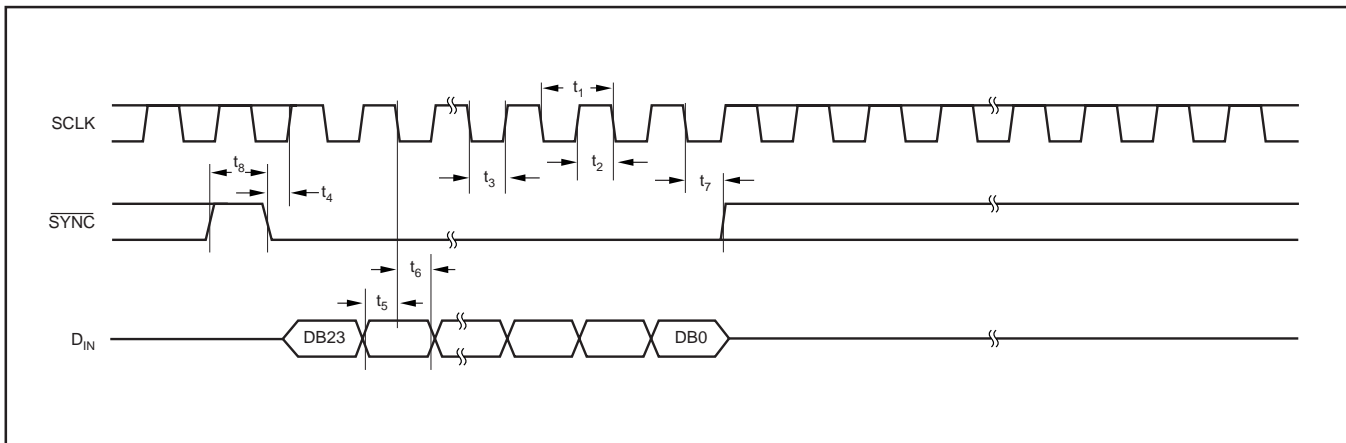

TYPICAL CHARACTERISTICS: $V_{DD} = 5V$

At $T_A = +25^\circ\text{C}$, $V_{DD} = 5V$, unless otherwise noted.

NOTE: All references to I_{DD} include I_{REF} current.

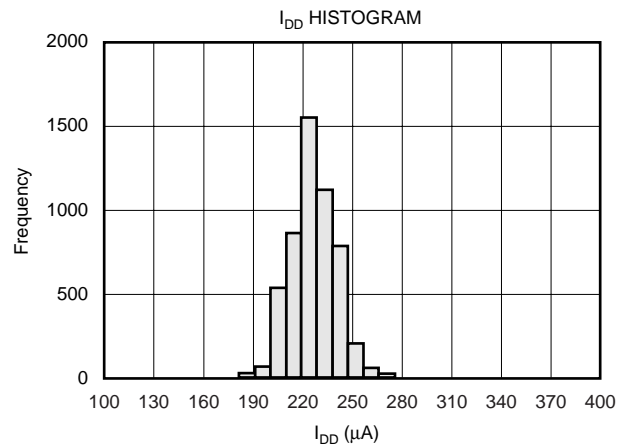
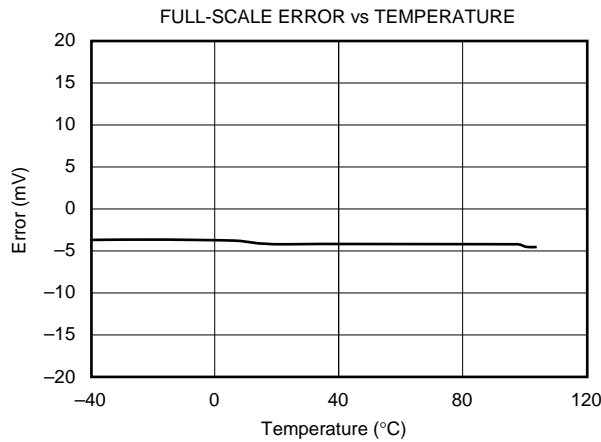
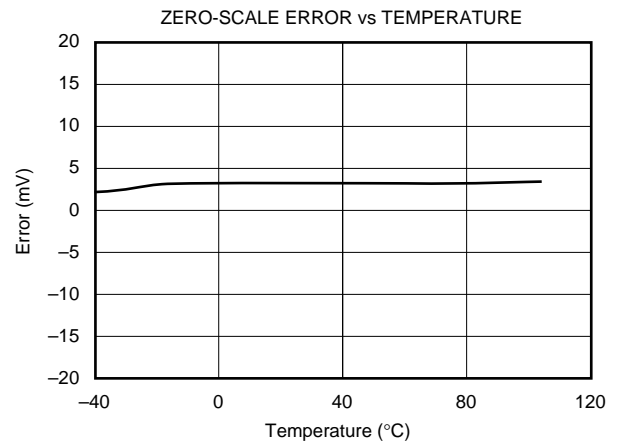
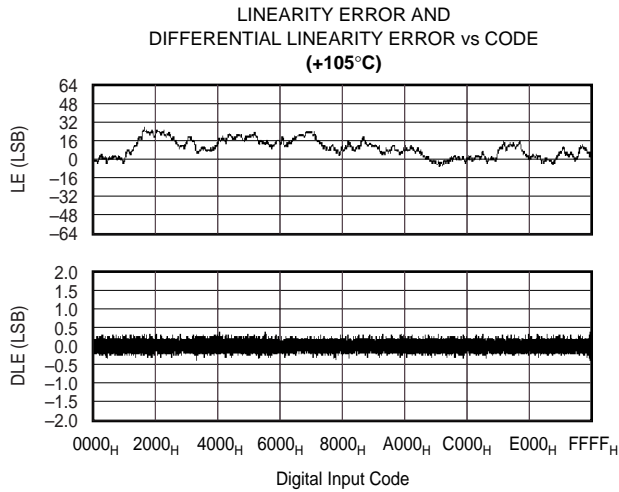
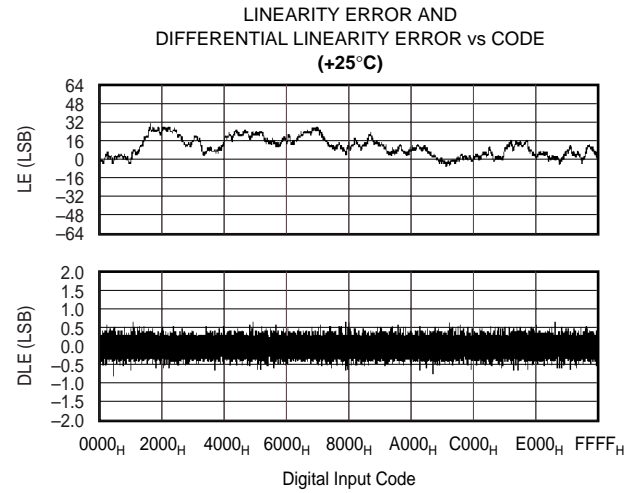
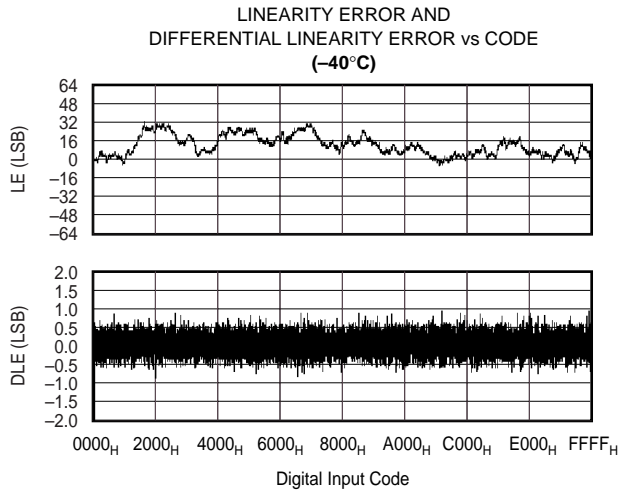

TYPICAL CHARACTERISTICS: $V_{DD} = 5V$ (Cont.)

At $T_A = +25^\circ\text{C}$, $V_{DD} = 5V$, unless otherwise noted.

NOTE: All references to I_{DD} include I_{REF} current.

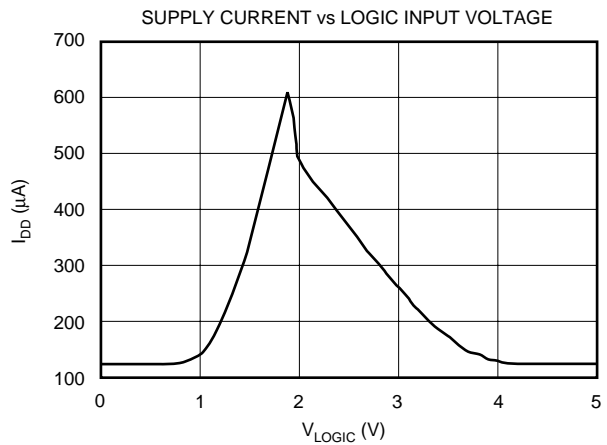
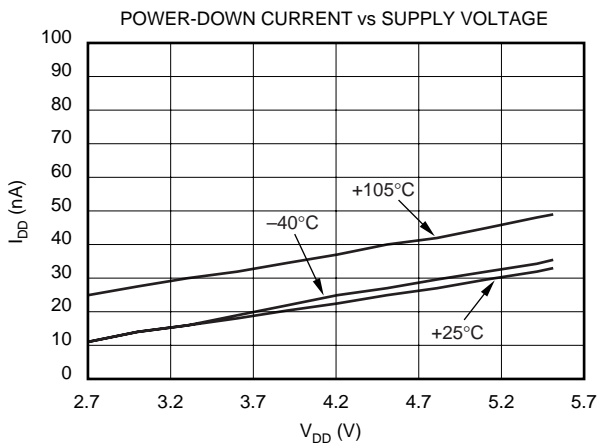
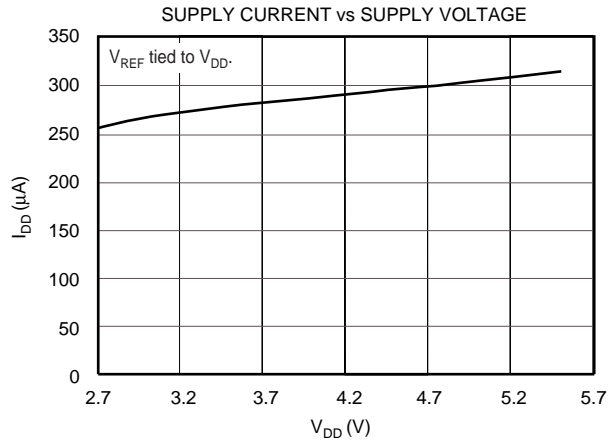
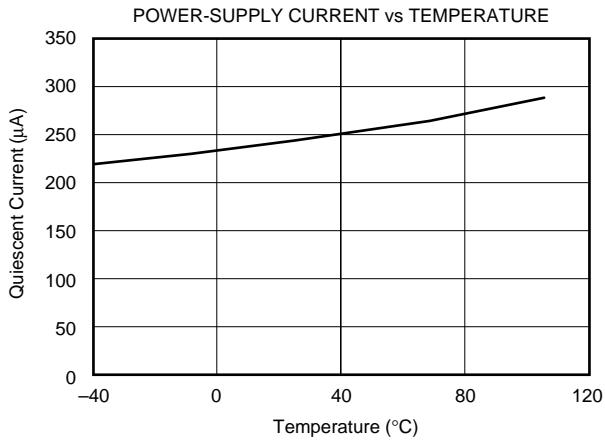
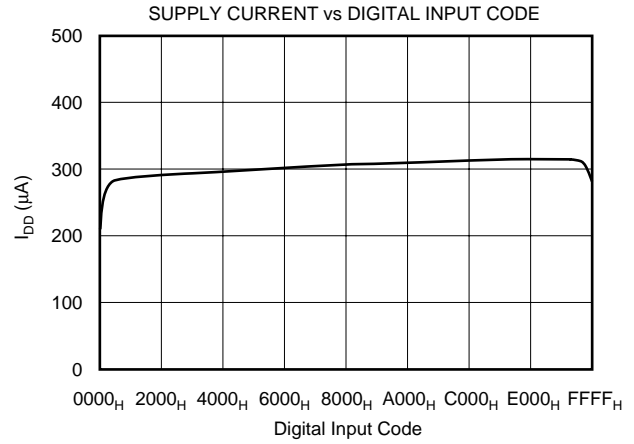
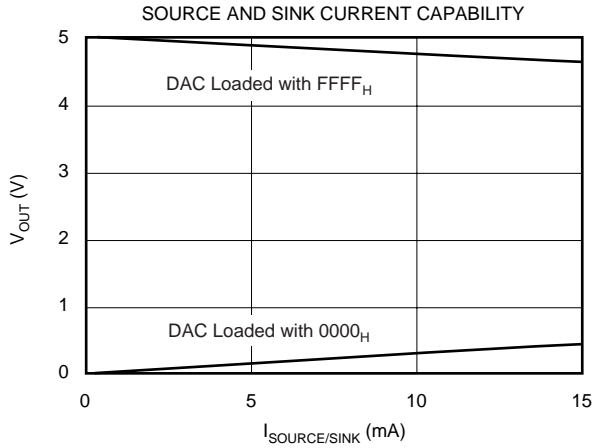

TYPICAL CHARACTERISTICS: $V_{DD} = 5V$ (Cont.)

At $T_A = +25^\circ C$, $V_{DD} = 5V$, unless otherwise noted.

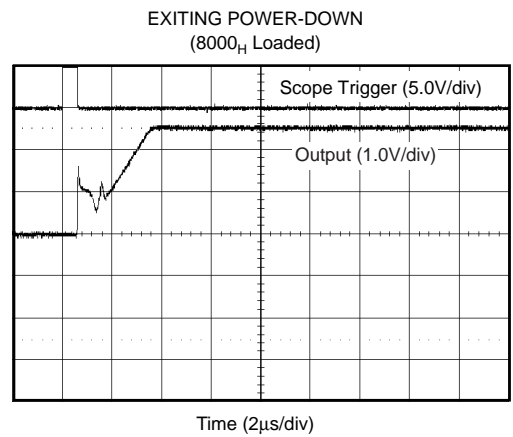
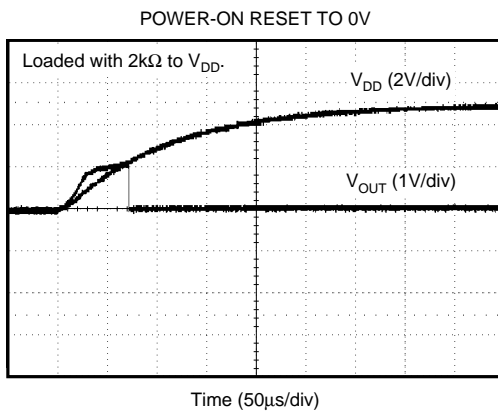
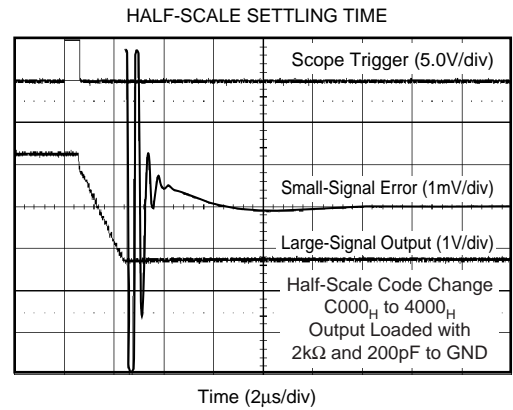
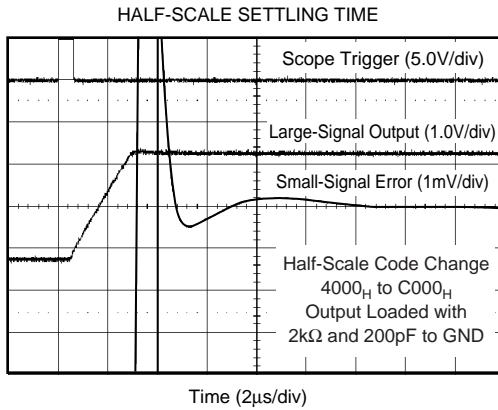
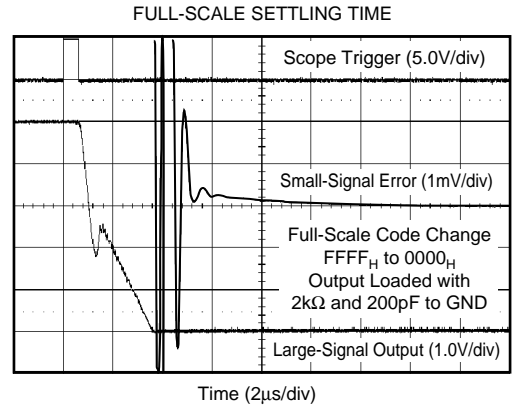
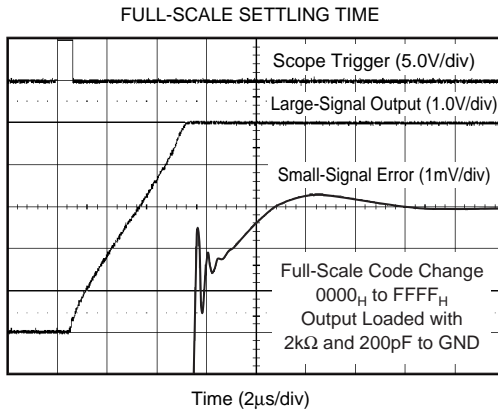

TYPICAL CHARACTERISTICS: $V_{DD} = 5V$ (Cont.)

At $T_A = +25^\circ\text{C}$, $V_{DD} = 5V$, unless otherwise noted.

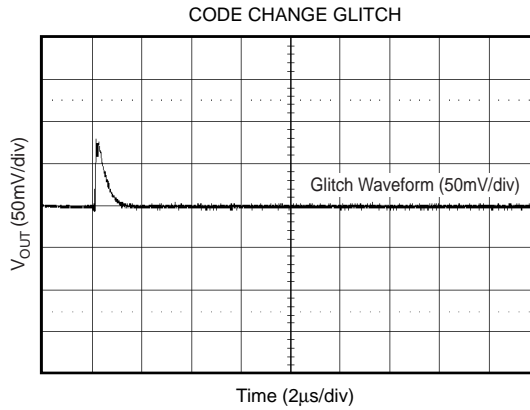

TYPICAL CHARACTERISTICS: $V_{DD} = 2.7V$

At $T_A = +25^\circ\text{C}$, $V_{DD} = 2.7V$, unless otherwise noted.

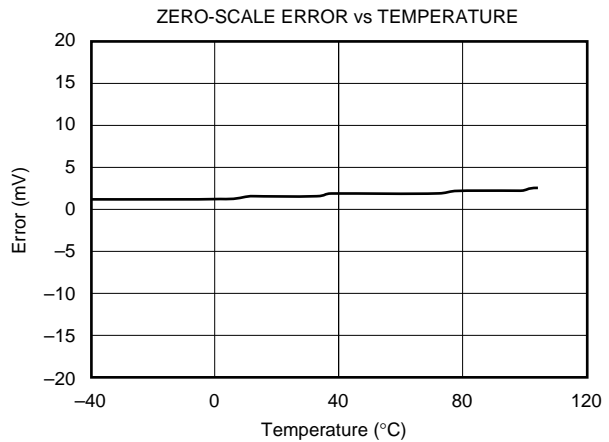
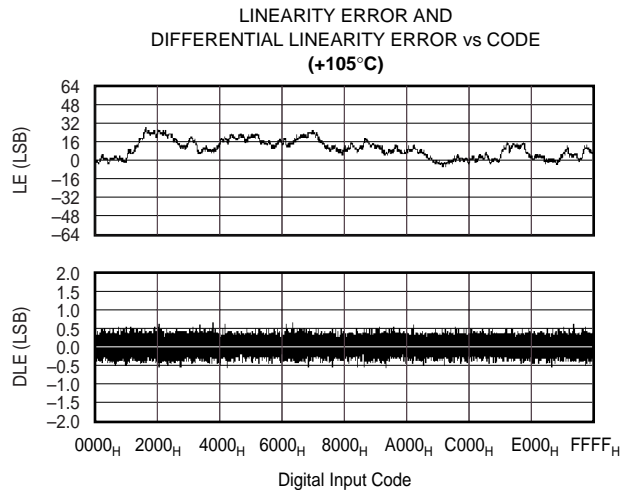
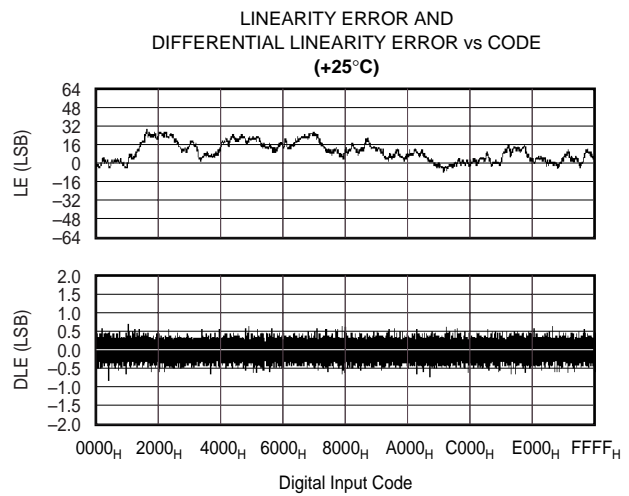
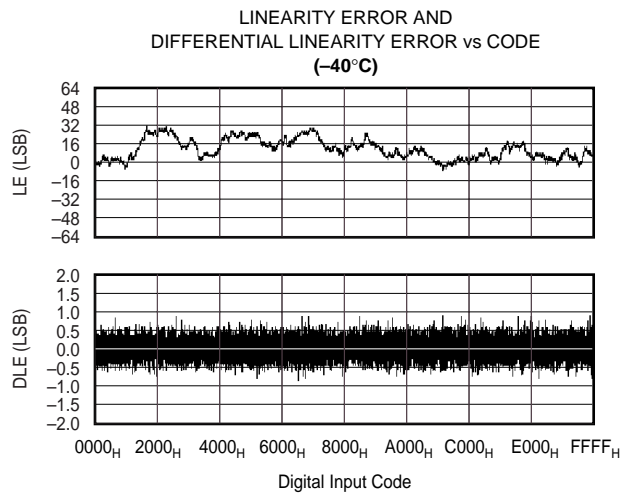

TYPICAL CHARACTERISTICS: $V_{DD} = 2.7V$

At $T_A = +25^\circ C$, $V_{DD} = 2.7V$, unless otherwise noted.

NOTE: All references to I_{DD} include I_{REF} current.

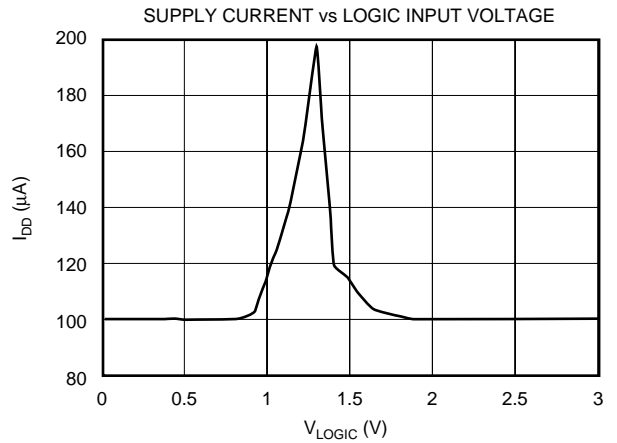
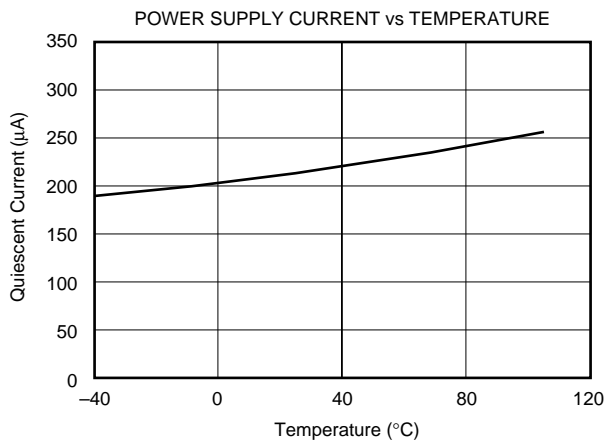
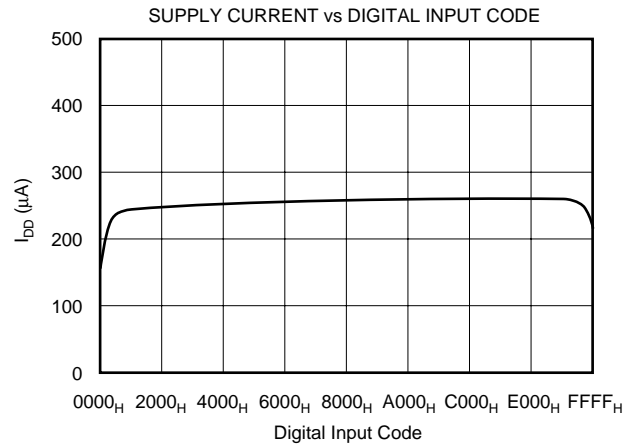
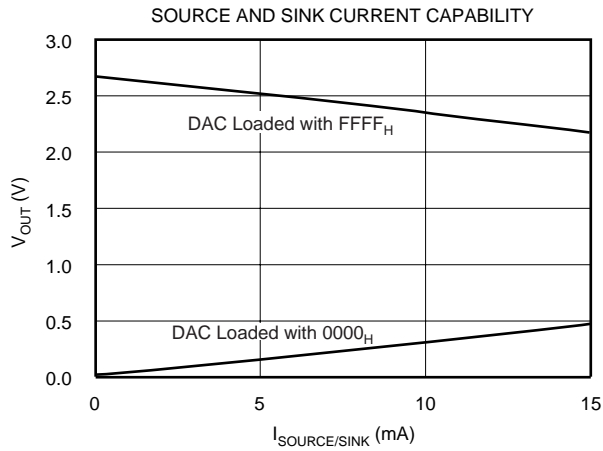
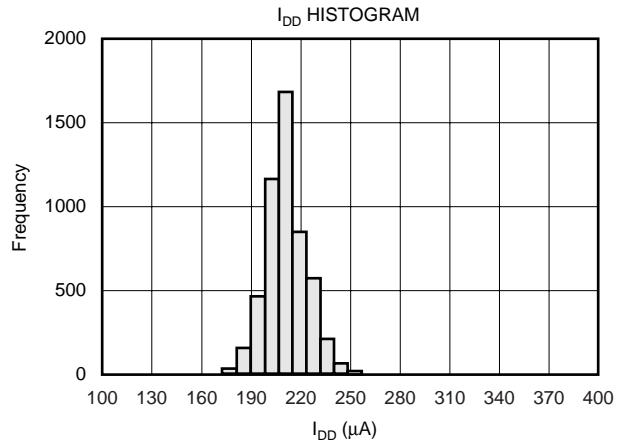
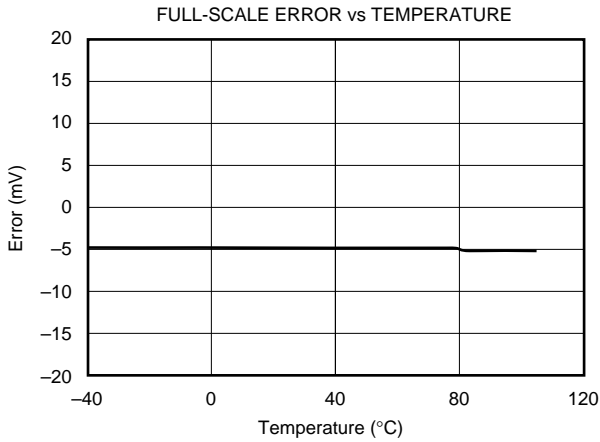

TYPICAL CHARACTERISTICS: $V_{DD} = 2.7V$ (Cont.)

At $T_A = +25^\circ C$, $V_{DD} = 2.7V$, unless otherwise noted.

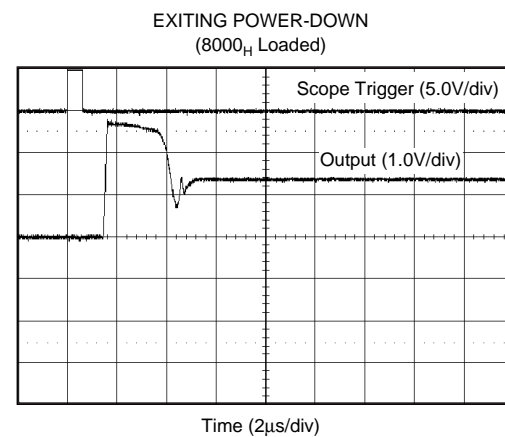
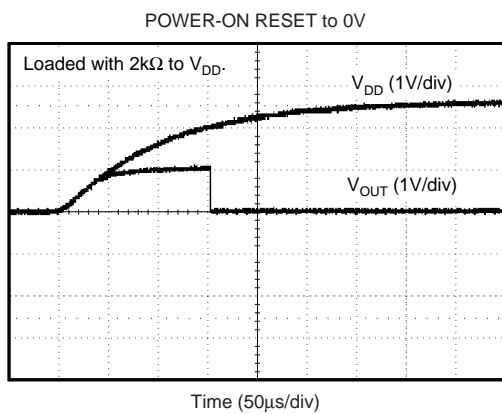
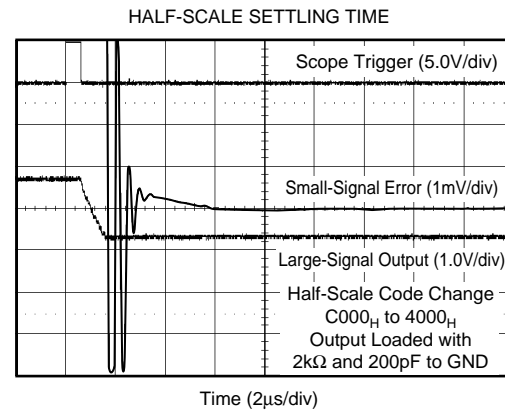
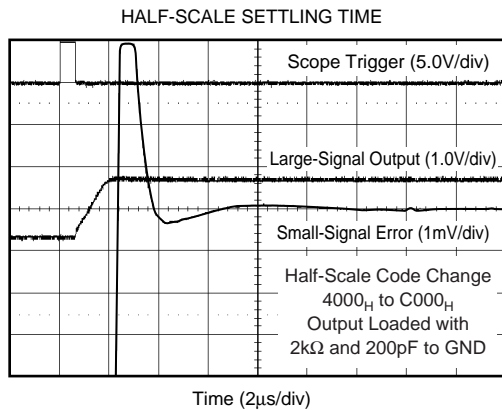
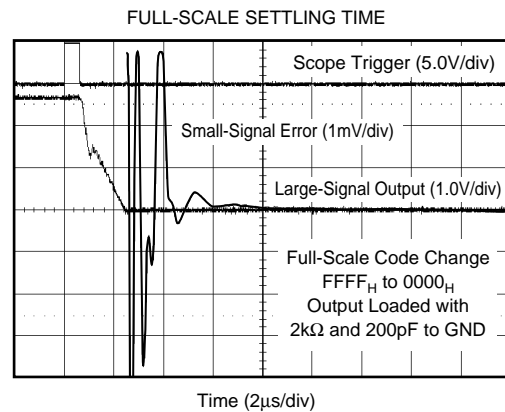
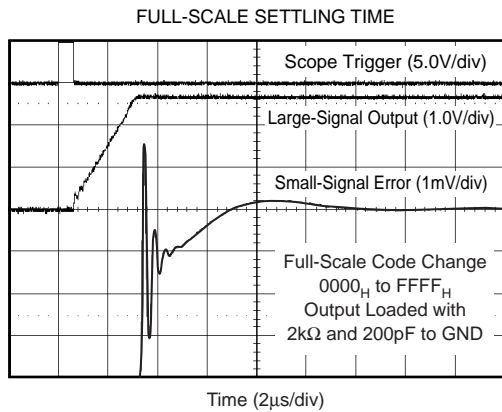

TYPICAL CHARACTERISTICS: $V_{DD} = 2.7V$ (Cont.)

At $T_A = +25^\circ C$, $V_{DD} = 2.7V$, unless otherwise noted.

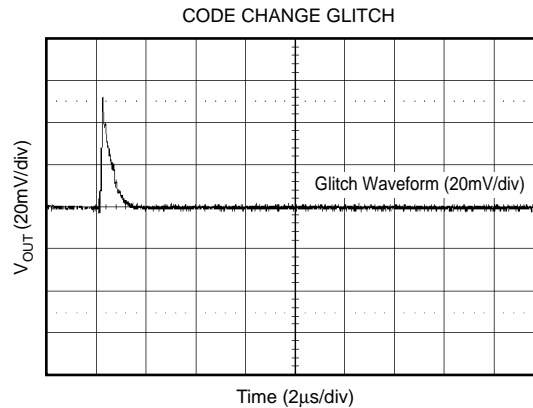

THEORY OF OPERATION

DAC SECTION

The architecture consists of a string DAC followed by an output buffer amplifier. Figure 1 shows a block diagram of the DAC architecture.

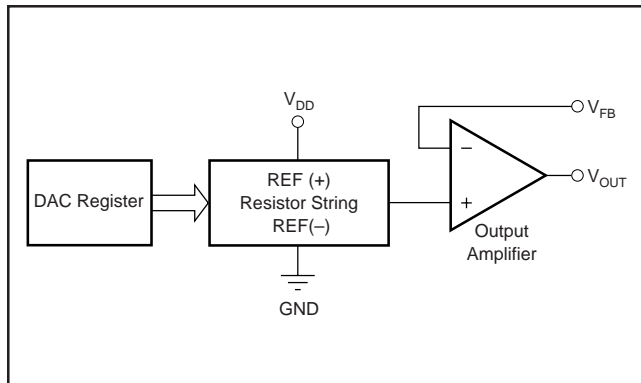

FIGURE 1. DAC8531 Architecture.

The input coding to the DAC8531 is straight binary, so the ideal output voltage is given by:

$$V_{OUT} = V_{REF} \cdot \frac{D}{65536}$$

where D = decimal equivalent of the binary code that is loaded to the DAC register; it can range from 0 to 65535.

RESISTOR STRING

Figure 2 shows the resistor string section. It is simply a string of resistors, each of value R . The code loaded into the DAC register determines at which node on the string the voltage is tapped off to be fed into the output amplifier by closing one of the switches connecting the string to the amplifier. It is ensured monotonic because it is a string of resistors.

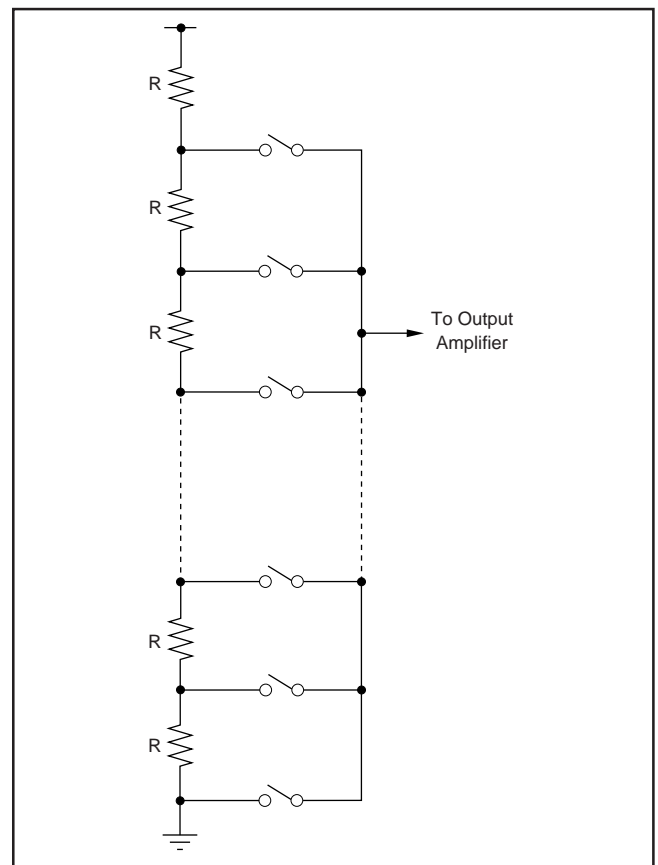

FIGURE 2. Resistor String.

OUTPUT AMPLIFIER

The output buffer amplifier is capable of generating rail-to-rail voltages on its output which gives an output range of 0V to V_{DD} . It is capable of driving a load of $2k\Omega$ in parallel with $1000pF$ to GND. The source and sink capabilities of the output amplifier can be seen in the typical curves. The slew rate is $1V/\mu s$ with a full-scale settling time of $8\mu s$ with the output unloaded.

The inverting input of the output amplifier is brought out to the V_{FB} pin. This allows for better accuracy in critical applications by tying the V_{FB} point and the amplifier output together directly at the load. Other signal conditioning circuitry may also be connected between these points for specific applications.

SERIAL INTERFACE

The DAC8531 has a three-wire serial interface (\overline{SYNC} , SCLK, and D_{IN}), which is compatible with SPI, QSPI, and Microwire interface standards as well as most DSPs. See the Serial Write Operation timing diagram for an example of a typical write sequence.

The write sequence begins by bringing the \overline{SYNC} line LOW. Data from the D_{IN} line is clocked into the 24-bit shift register on the falling edge of SCLK. The serial clock frequency can be as high as 30MHz, making the DAC8531 compatible with high-speed (DSPs). On the 24th falling edge of the serial clock, the last data bit is clocked in and the programmed function is executed (i.e., a change in DAC register contents and/or a change in the mode of operation).

At this point, the \overline{SYNC} line may be kept LOW or brought HIGH. In either case, it must be brought HIGH for a minimum of $33ns$ before the next write sequence so that a falling edge of \overline{SYNC} can initiate the next write sequence. Since the

\overline{SYNC} buffer draws more current when the \overline{SYNC} signal is HIGH than it does when it is LOW, \overline{SYNC} should be idled LOW between write sequences for lowest power operation of the part. As mentioned above, it must be brought HIGH again just before the next write sequence.

INPUT SHIFT REGISTER

The input shift register is 24 bits wide, as shown in Figure 3. The first six bits are “don’t cares”. The next two bits (PD1 and PD0) are control bits that control which mode of operation the part is in (normal mode or any one of three power-down modes). There is a more complete description of the various modes in the Power-Down Modes section. The next 16 bits are the data bits. These are transferred to the DAC register on the 24th falling edge of SCLK.

\overline{SYNC} INTERRUPT

In a normal write sequence, the \overline{SYNC} line is kept LOW for at least 24 falling edges of SCLK and the DAC is updated on the 24th falling edge. However, if \overline{SYNC} is brought HIGH before the 24th falling edge, this acts as an interrupt to the write sequence. The shift register is reset and the write sequence is seen as invalid. Neither an update of the DAC register contents or a change in the operating mode occurs, as shown in Figure 4.

POWER-ON RESET

The DAC8531 contains a power-on reset circuit that controls the output voltage during power-up. On power-up, the DAC register is filled with zeros and the output voltage is 0V; it remains there until a valid write sequence is made to the DAC. This is useful in applications where it is important to know the state of the output of the DAC while it is in the process of powering up.

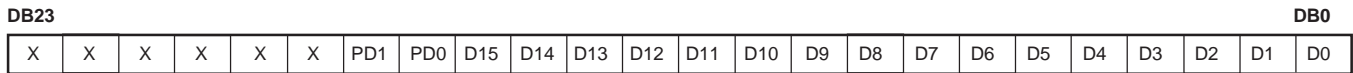

FIGURE 3. Data Input Register.

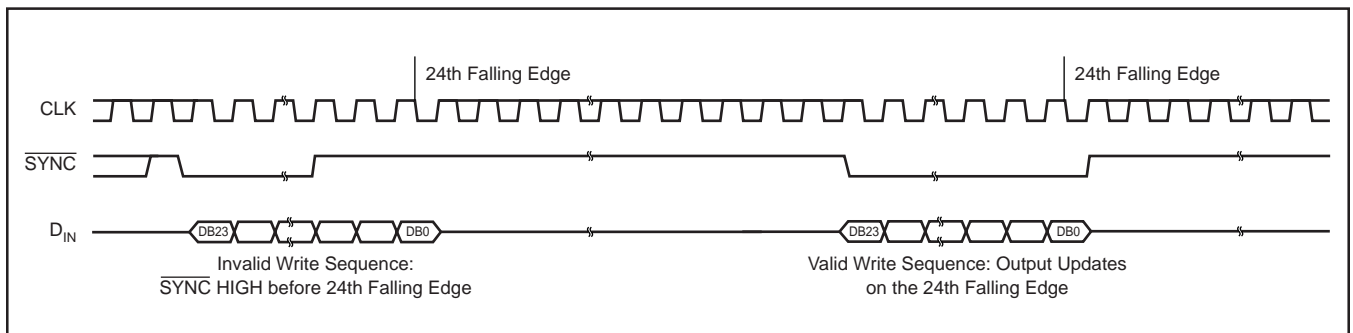

FIGURE 4. \overline{SYNC} Interrupt Facility.

POWER-DOWN MODES

The DAC8531 supports four separate modes of operation. These modes are programmable by setting two bits (PD1 and PD0) in the control register. Table I shows how the state of the bits corresponds to the mode of operation of the device.

PD1 (DB17)	PD0 (DB16)	OPERATING MODE
0	0	Normal Operation
—	—	Power-Down Modes
0	1	Output 1kΩ to GND
1	0	Output 100kΩ to GND
1	1	High-Z

TABLE I. Modes of Operation for the DAC8531.

When both bits are set to 0, the part works normally with its typical current consumption of 250μA at 5V. However, for the three power-down modes, the supply current falls to 200nA at 5V (50nA at 3V). Not only does the supply current fall, but the output stage is also internally switched from the output of the amplifier to a resistor network of known values. This has the advantage that the output impedance of the part is known while the part is in power-down mode. There are three different options. The output is connected internally to GND through a 1kΩ resistor, a 100kΩ resistor, or it is left open-circuited (High-Z). The output stage is illustrated in Figure 5.

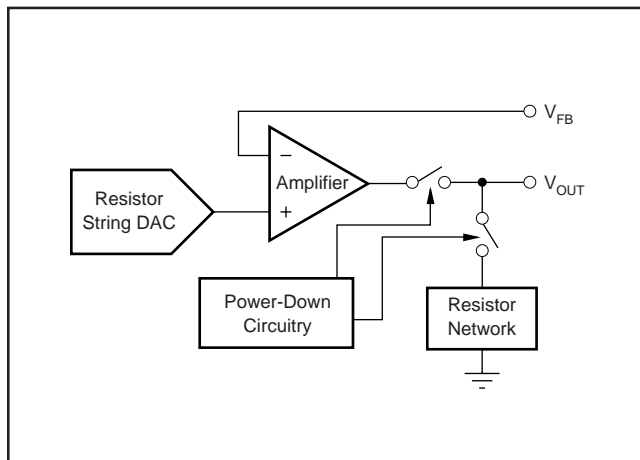

FIGURE 5. Output Stage During Power-Down.

All linear circuitry is shut down when the power-down mode is activated. However, the contents of the DAC register are unaffected when in power-down. The time to exit power-down is typically 2.5μs for $V_{DD} = 5V$, and 5μs for $V_{DD} = 3V$. See the Typical Characteristics for more information.

MICROPROCESSOR INTERFACING

DAC8531 TO 8051 INTERFACE

Figure 6 shows a serial interface between the DAC8531 and a typical 8051-type microcontroller. The setup for the interface is as follows: TXD of the 8051 drives SCLK of the DAC8531, while RXD drives the serial data line of the part. The SYNC signal is derived from a bit-programmable pin on the port. In this case, port line P3.3 is used. When data is to be transmitted to the DAC8531, P3.3 is taken LOW. The 8051 transmits data only in 8-bit bytes; thus only eight falling clock edges occur in the transmit cycle. To load data to the DAC, P3.3 is left LOW after the first eight bits are transmitted and a second write cycle is initiated to transmit the second byte of data. P3.3 is taken HIGH following the completion of the third write cycle. The 8051 outputs the serial data in a format which has the LSB first. The DAC8531 requires its data with the MSB as the first bit received. The 8051 transmit routine must therefore take this into account, and “mirror” the data as needed.

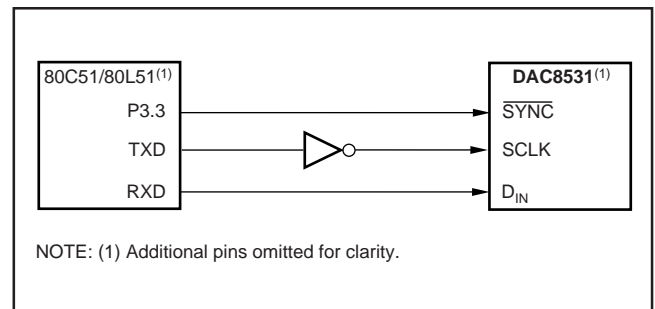

FIGURE 6. DAC8531 to 80C51/80L51 Interface.

DAC8531 TO Microwire INTERFACE

Figure 7 shows an interface between the DAC8531 and any Microwire compatible device. Serial data is shifted out on the falling edge of the serial clock and is clocked into the DAC8531 on the rising edge of the SK signal.

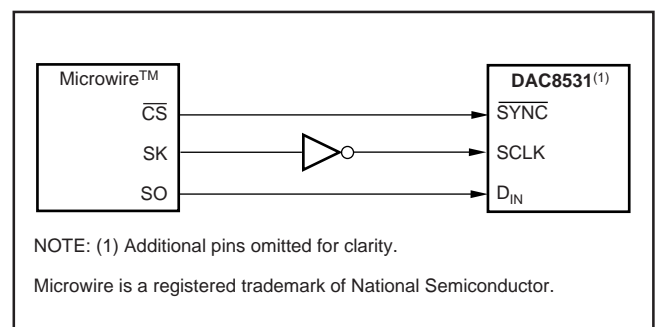

FIGURE 7. DAC8531 to Microwire Interface.

DAC8531 TO 68HC11 INTERFACE

Figure 8 shows a serial interface between the DAC8531 and the 68HC11 microcontroller. SCK of the 68HC11 drives the SCLK of the DAC8531, while the MOSI output drives the serial data line of the DAC. The $\overline{\text{SYNC}}$ signal is derived from a port line (PC7), similar to what was done for the 8051.

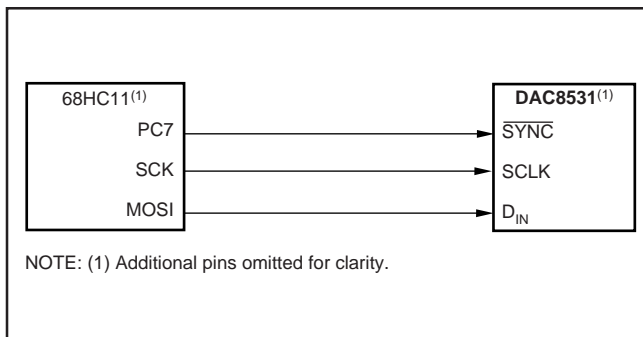

FIGURE 8. DAC8531 to 68HC11 Interface.

The 68HC11 should be configured so that its CPOL bit is a 0 and its CPHA bit is a 1. This configuration causes data appearing on the MOSI output to be valid on the falling edge of SCK. When data is being transmitted to the DAC, the $\overline{\text{SYNC}}$ line is taken LOW (PC7). Serial data from the 68HC11 is transmitted in 8-bit bytes with only eight falling clock edges occurring in the transmit cycle. Data is transmitted MSB first. In order to load data to the DAC8531, PC7 is left LOW after the first eight bits are transferred, then a second and third serial write operation is performed to the DAC and PC7 is taken HIGH at the end of this procedure.

APPLICATIONS

USING REF02 AS A POWER SUPPLY FOR THE DAC8531

Due to the extremely low supply current required by the DAC8531, an alternative option is to use a REF02 +5V precision voltage reference to supply the required voltage to the part, as shown in Figure 9. This is especially useful if the

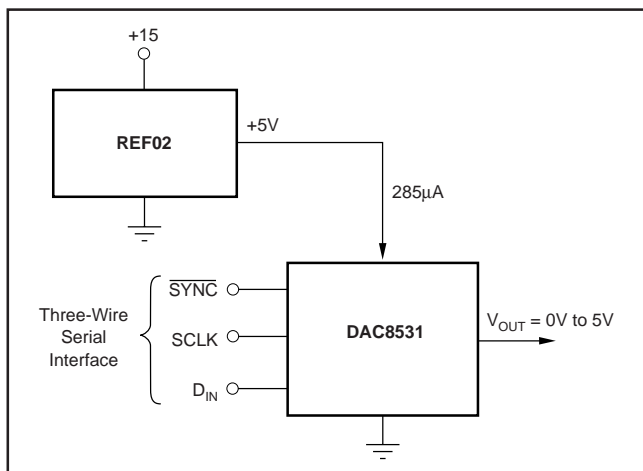

FIGURE 9. REF02 as a Power Supply to the DAC8531.

power supply is quite noisy or if the system supply voltages are at some value other than 5V. The REF02 will output a steady supply voltage for the DAC8531. If the REF02 is used, the typical current it needs to supply to the DAC8531 is 250µA. This is with no load on the output of the DAC. When the DAC output is loaded, the REF02 also needs to supply the current to the load. The total current required (with a 5kΩ load on the DAC output) is:

$$250\mu\text{A} + (5\text{V}/5\text{k}\Omega) = 1.29\text{mA}$$

The load regulation of the REF02 is typically 0.005%/mA, which results in an error of 322µV for the 1.29mA current drawn from it. This corresponds to a 4.2LSB error.

BIPOLAR OPERATION USING THE DAC8531

The DAC8531 has been designed for single-supply operation but a bipolar output range is also possible using the circuit in Figure 10. The circuit shown will give an output voltage range of $\pm V_{\text{REF}}$. Rail-to-rail operation at the amplifier output is achievable using an OPA703 as the output amplifier.

The output voltage for any input code can be calculated as follows:

$$V_O = \left[V_{\text{REF}} \cdot \left(\frac{D}{65536} \right) \cdot \left(\frac{R_1 + R_2}{R_1} \right) - V_{\text{REF}} \cdot \left(\frac{R_2}{R_1} \right) \right]$$

where D represents the input code in decimal (0–65535).

With $V_{\text{REF}} = 5\text{V}$, $R_1 = R_2 = 10\text{k}\Omega$:

$$V_O = \left(\frac{10 \cdot D}{65536} \right) - 5\text{V}$$

This is an output voltage range of $\pm 5\text{V}$ with 0000_H corresponding to a -5V output and FFFF_H corresponding to a $+5\text{V}$ output. Similarly, using $V_{\text{REF}} = 2.5\text{V}$, $\pm 2.5\text{V}$ output voltage range can be achieved.

LAYOUT

A precision analog component requires careful layout, adequate bypassing, and clean, well-regulated power supplies.

As the DAC8531 offers single-supply operation, it will often be used in close proximity with digital logic, microcontrollers, microprocessors, and digital signal processors. The more digital logic present in the design and the higher the switching speed, the more difficult it will be to keep digital noise from appearing at the output.

Due to the single ground pin of the DAC8531, all return currents, including digital and analog return currents, must flow through the GND pin. Ideally, GND would be connected directly to an analog ground plane. This plane would be separate from the ground connection for the digital components until they were connected at the power-entry point of the system.

The power applied to V_{DD} should be well regulated and low noise. Switching power supplies and DC/DC converters will often have high-frequency glitches or spikes riding on the output voltage. In addition, digital components can create similar high-frequency spikes as their internal logic switches states. This noise can easily couple into the DAC output voltage through various paths between the power connections and analog output.

As with the GND connection, V_{DD} should be connected to a +5V power-supply plane or trace that is separate from the connection for digital logic until they are connected at the power-entry point. In addition, the $1\mu\text{F}$ to $10\mu\text{F}$ and $0.1\mu\text{F}$ bypass capacitors are strongly recommended. In some situations, additional bypassing may be required, such as a $100\mu\text{F}$ electrolytic capacitor or even a “Pi” filter made up of inductors and capacitors—all designed to essentially low-pass filter the +5V supply, removing the high-frequency noise.

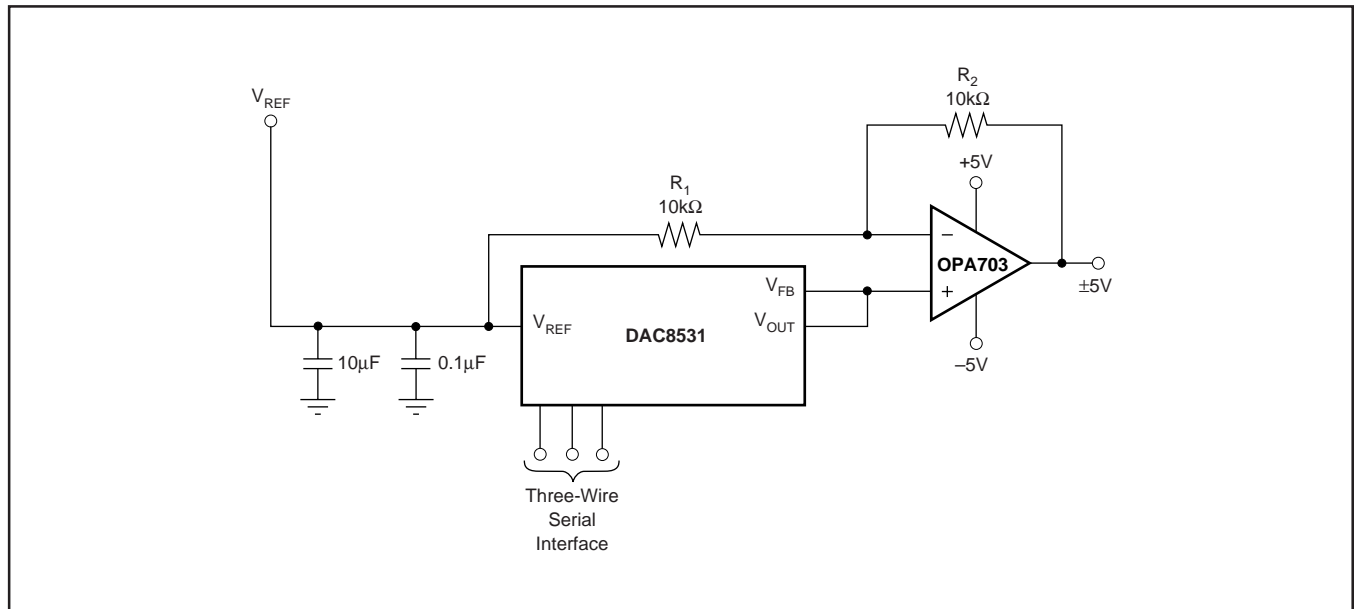
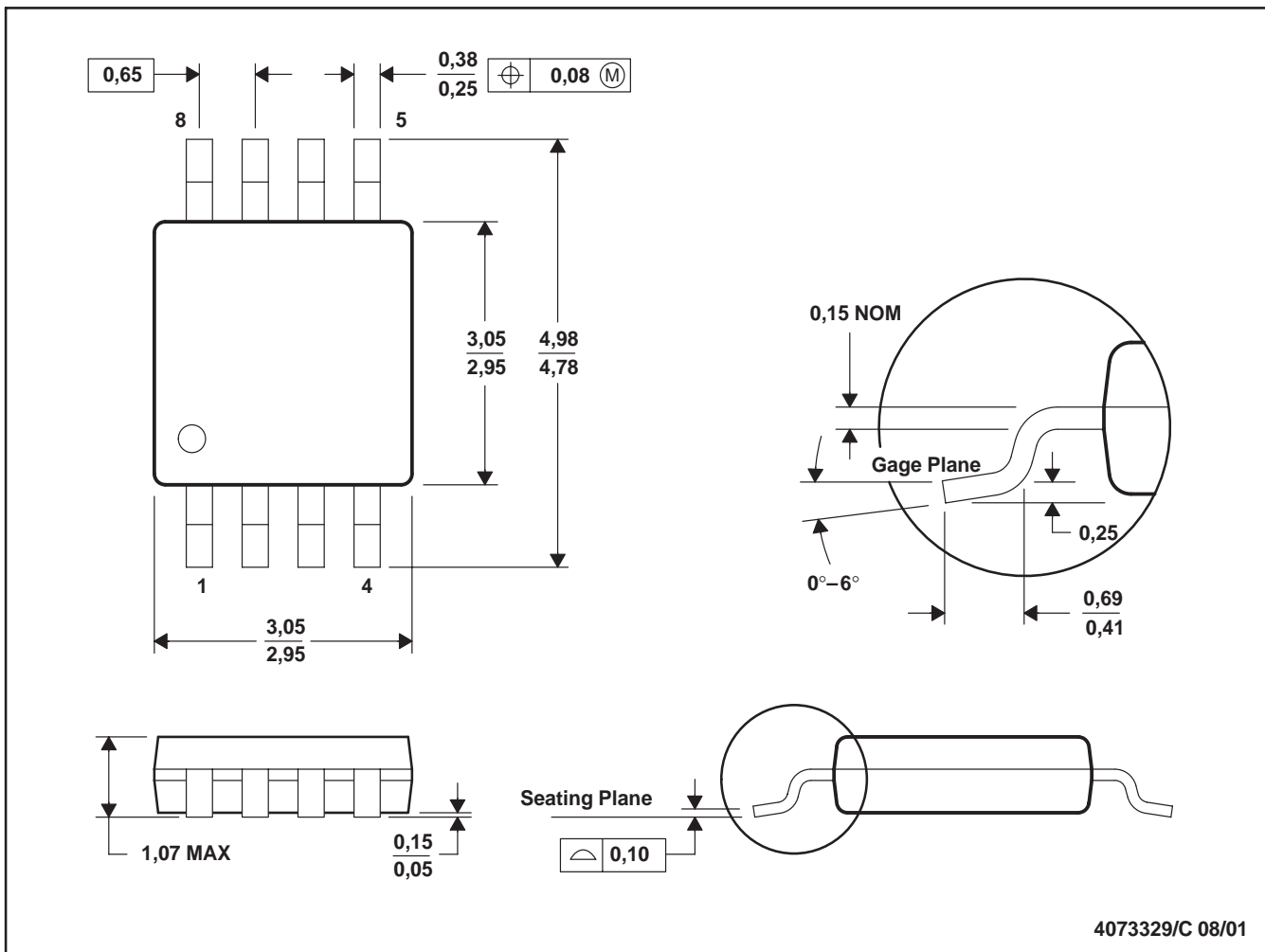
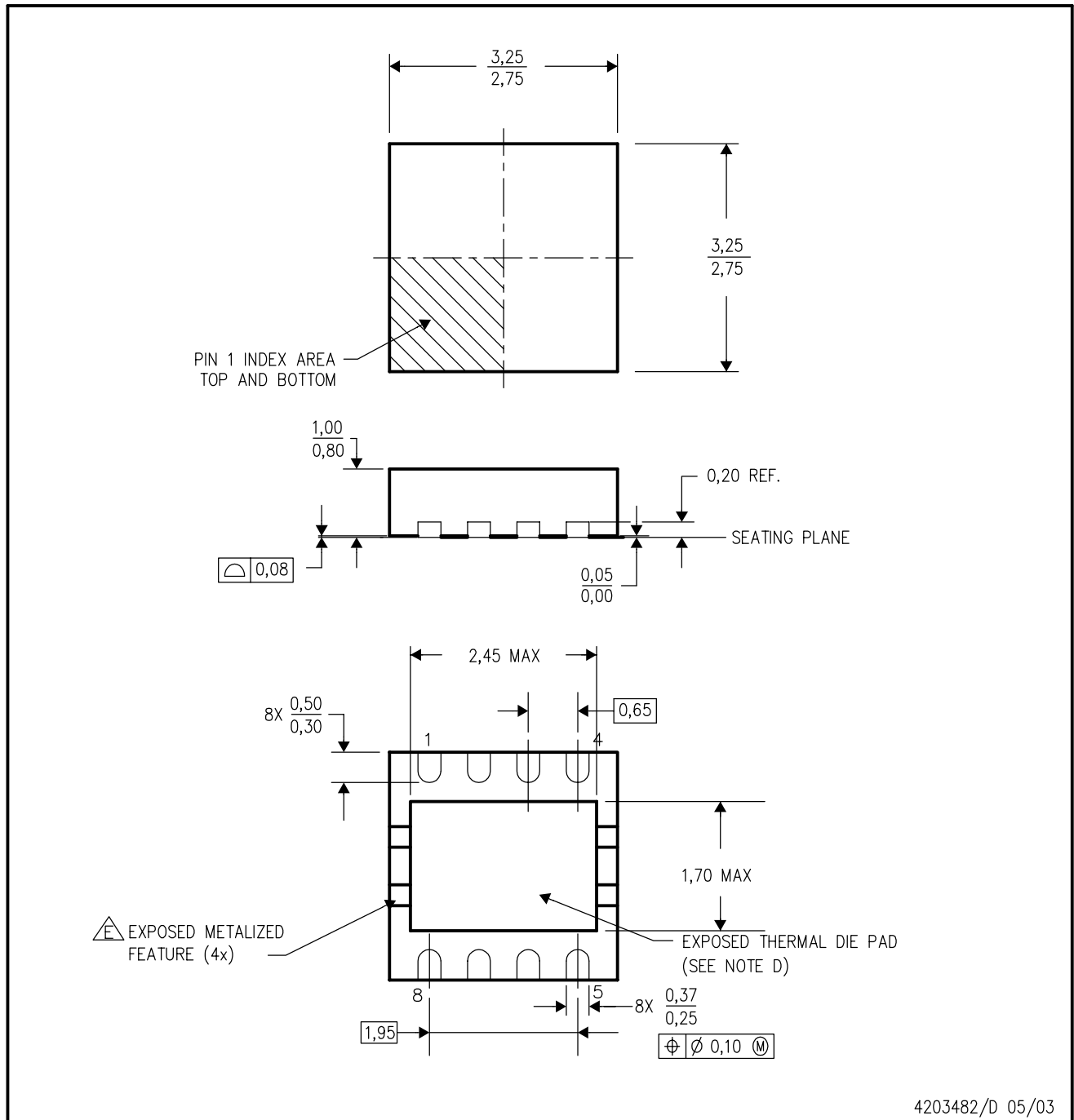

FIGURE 10. Bipolar Operation with the DAC8531.



- NOTES:
- A. All linear dimensions are in millimeters.
 - B. This drawing is subject to change without notice.
 - C. Body dimensions do not include mold flash or protrusion.
 - D. Falls within JEDEC MO-187



4203482/D 05/03

- NOTES:
- A. All linear dimensions are in millimeters.
 - B. This drawing is subject to change without notice.
 - C. Small Outline No-Lead (SON) package configuration.
 - D. The package thermal performance may be enhanced by bonding the thermal die pad to an external thermal plane.
 - E. Metalized features are supplier options and may not be on the package.

PACKAGING INFORMATION

Orderable Device	Status ⁽¹⁾	Package Type	Package Drawing	Pins	Package Qty	Eco Plan ⁽²⁾	Lead/ Ball Finish	MSL Peak Temp ⁽³⁾	Samples (Requires Login)
DAC8531E/250	ACTIVE	VSSOP	DGK	8	250	Green (RoHS & no Sb/Br)	CU NIPDAUAG	Level-2-260C-1 YEAR	
DAC8531E/250G4	ACTIVE	VSSOP	DGK	8	250	Green (RoHS & no Sb/Br)	CU NIPDAUAG	Level-2-260C-1 YEAR	
DAC8531E/2K5	ACTIVE	VSSOP	DGK	8	2500	Green (RoHS & no Sb/Br)	CU NIPDAUAG	Level-2-260C-1 YEAR	
DAC8531E/2K5G4	ACTIVE	VSSOP	DGK	8	2500	Green (RoHS & no Sb/Br)	CU NIPDAUAG	Level-2-260C-1 YEAR	
DAC8531IDRBR	ACTIVE	SON	DRB	8	3000	Green (RoHS & no Sb/Br)	CU NIPDAU	Level-2-260C-1 YEAR	
DAC8531IDRBRG4	ACTIVE	SON	DRB	8	3000	Green (RoHS & no Sb/Br)	CU NIPDAU	Level-2-260C-1 YEAR	
DAC8531IDRBT	ACTIVE	SON	DRB	8	250	Green (RoHS & no Sb/Br)	CU NIPDAU	Level-2-260C-1 YEAR	
DAC8531IDRBTG4	ACTIVE	SON	DRB	8	250	Green (RoHS & no Sb/Br)	CU NIPDAU	Level-2-260C-1 YEAR	

⁽¹⁾ The marketing status values are defined as follows:

ACTIVE: Product device recommended for new designs.

LIFEBUY: TI has announced that the device will be discontinued, and a lifetime-buy period is in effect.

NRND: Not recommended for new designs. Device is in production to support existing customers, but TI does not recommend using this part in a new design.

PREVIEW: Device has been announced but is not in production. Samples may or may not be available.

OBSOLETE: TI has discontinued the production of the device.

⁽²⁾ Eco Plan - The planned eco-friendly classification: Pb-Free (RoHS), Pb-Free (RoHS Exempt), or Green (RoHS & no Sb/Br) - please check <http://www.ti.com/productcontent> for the latest availability information and additional product content details.

TBD: The Pb-Free/Green conversion plan has not been defined.

Pb-Free (RoHS): TI's terms "Lead-Free" or "Pb-Free" mean semiconductor products that are compatible with the current RoHS requirements for all 6 substances, including the requirement that lead not exceed 0.1% by weight in homogeneous materials. Where designed to be soldered at high temperatures, TI Pb-Free products are suitable for use in specified lead-free processes.

Pb-Free (RoHS Exempt): This component has a RoHS exemption for either 1) lead-based flip-chip solder bumps used between the die and package, or 2) lead-based die adhesive used between the die and leadframe. The component is otherwise considered Pb-Free (RoHS compatible) as defined above.

Green (RoHS & no Sb/Br): TI defines "Green" to mean Pb-Free (RoHS compatible), and free of Bromine (Br) and Antimony (Sb) based flame retardants (Br or Sb do not exceed 0.1% by weight in homogeneous material)

⁽³⁾ MSL, Peak Temp. -- The Moisture Sensitivity Level rating according to the JEDEC industry standard classifications, and peak solder temperature.

Important Information and Disclaimer: The information provided on this page represents TI's knowledge and belief as of the date that it is provided. TI bases its knowledge and belief on information provided by third parties, and makes no representation or warranty as to the accuracy of such information. Efforts are underway to better integrate information from third parties. TI has taken and continues to take reasonable steps to provide representative and accurate information but may not have conducted destructive testing or chemical analysis on incoming materials and chemicals. TI and TI suppliers consider certain information to be proprietary, and thus CAS numbers and other limited information may not be available for release.

In no event shall TI's liability arising out of such information exceed the total purchase price of the TI part(s) at issue in this document sold by TI to Customer on an annual basis.

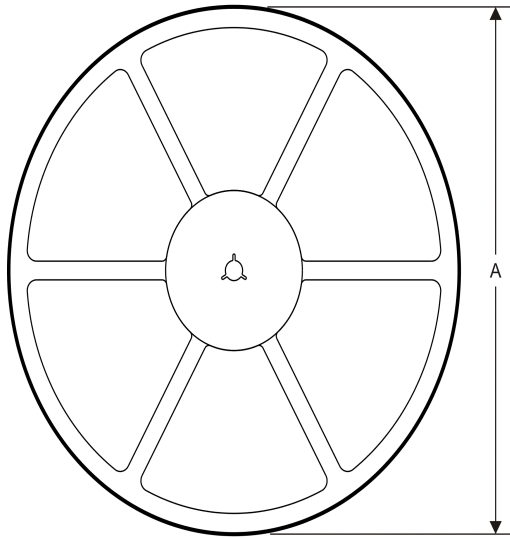
TAPE AND REEL INFORMATION
REEL DIMENSIONS

TAPE DIMENSIONS

A0	Dimension designed to accommodate the component width
B0	Dimension designed to accommodate the component length
K0	Dimension designed to accommodate the component thickness
W	Overall width of the carrier tape
P1	Pitch between successive cavity centers

TAPE AND REEL INFORMATION

*All dimensions are nominal

Device	Package Type	Package Drawing	Pins	SPQ	Reel Diameter (mm)	Reel Width W1 (mm)	A0 (mm)	B0 (mm)	K0 (mm)	P1 (mm)	W (mm)	Pin1 Quadrant
DAC8531E/250	VSSOP	DGK	8	250	180.0	12.4	5.3	3.4	1.4	8.0	12.0	Q1
DAC8531E/2K5	VSSOP	DGK	8	2500	330.0	12.4	5.3	3.4	1.4	8.0	12.0	Q1
DAC8531IDRBR	SON	DRB	8	3000	330.0	12.4	3.3	3.3	1.1	8.0	12.0	Q2
DAC8531IDRBT	SON	DRB	8	250	180.0	12.4	3.3	3.3	1.1	8.0	12.0	Q2

TAPE AND REEL BOX DIMENSIONS

*All dimensions are nominal

Device	Package Type	Package Drawing	Pins	SPQ	Length (mm)	Width (mm)	Height (mm)
DAC8531E/250	VSSOP	DGK	8	250	210.0	185.0	35.0
DAC8531E/2K5	VSSOP	DGK	8	2500	367.0	367.0	35.0
DAC8531IDRBR	SON	DRB	8	3000	367.0	367.0	35.0
DAC8531IDRBT	SON	DRB	8	250	210.0	185.0	35.0

DRB (S-PVSON-N8)

PLASTIC SMALL OUTLINE NO-LEAD

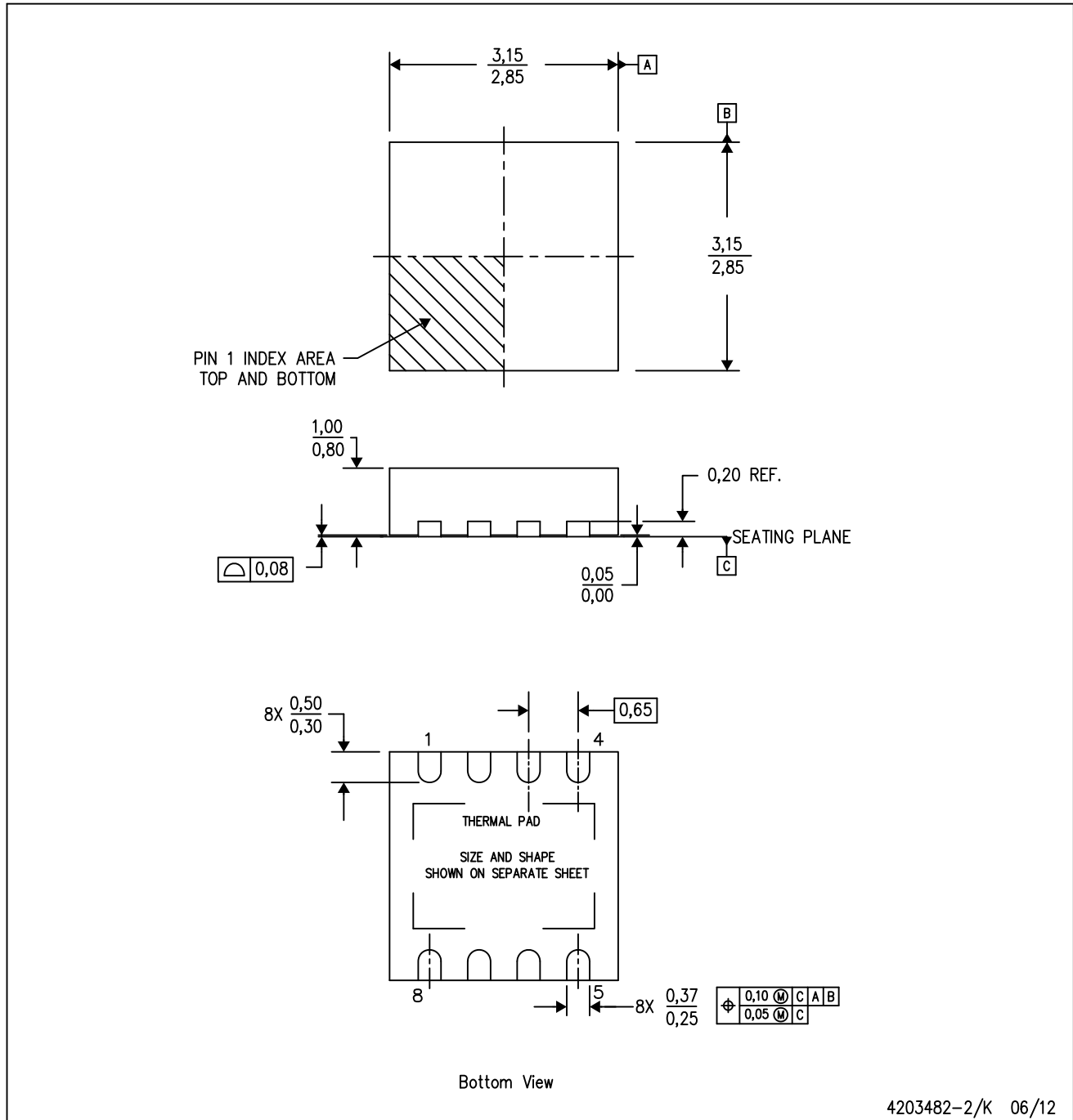

- NOTES:
- All linear dimensions are in millimeters. Dimensioning and tolerancing per ASME Y14.5M-1994.
 - This drawing is subject to change without notice.
 - Small Outline No-Lead (SON) package configuration.
 - The package thermal pad must be soldered to the board for thermal and mechanical performance.
 - See the additional figure in the Product Data Sheet for details regarding the exposed thermal pad features and dimensions.

THERMAL INFORMATION

This package incorporates an exposed thermal pad that is designed to be attached directly to an external heatsink. The thermal pad must be soldered directly to the printed circuit board (PCB). After soldering, the PCB can be used as a heatsink. In addition, through the use of thermal vias, the thermal pad can be attached directly to the appropriate copper plane shown in the electrical schematic for the device, or alternatively, can be attached to a special heatsink structure designed into the PCB. This design optimizes the heat transfer from the integrated circuit (IC).

For information on the Quad Flatpack No-Lead (QFN) package and its advantages, refer to Application Report, QFN/SON PCB Attachment, Texas Instruments Literature No. SLUA271. This document is available at www.ti.com.

The exposed thermal pad dimensions for this package are shown in the following illustration.

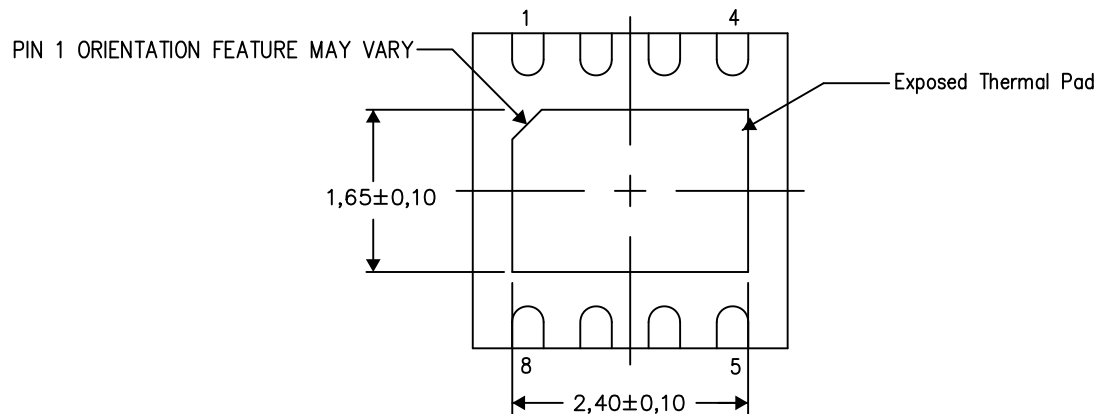

Bottom View

Exposed Thermal Pad Dimensions

4206340-3/M 06/12

NOTE: All linear dimensions are in millimeters

DRB (S-PVSON-N8)

PLASTIC SMALL OUTLINE NO-LEAD

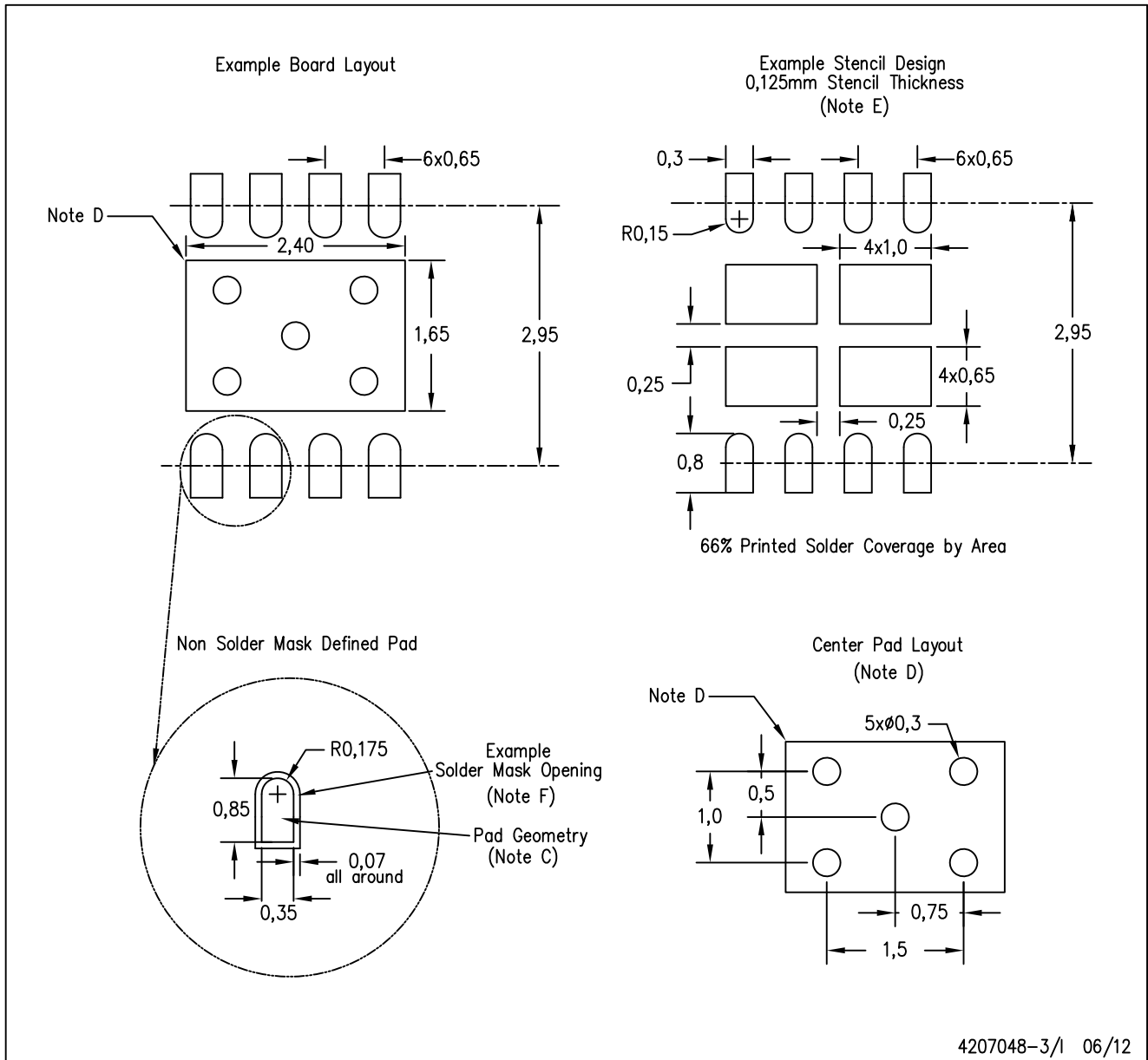

4207048-3/1 06/12

- NOTES:
- All linear dimensions are in millimeters.
 - This drawing is subject to change without notice.
 - Publication IPC-7351 is recommended for alternate designs.
 - This package is designed to be soldered to a thermal pad on the board. Refer to Application Note, QFN Packages, Texas Instruments Literature No. SLUA271, and also the Product Data Sheets for specific thermal information, via requirements, and recommended board layout. These documents are available at www.ti.com <<http://www.ti.com>>.
 - Laser cutting apertures with trapezoidal walls and also rounding corners will offer better paste release. Customers should contact their board assembly site for stencil design recommendations. Refer to IPC 7525 for stencil design considerations.
 - Customers should contact their board fabrication site for solder mask tolerances.

IMPORTANT NOTICE

Texas Instruments Incorporated and its subsidiaries (TI) reserve the right to make corrections, enhancements, improvements and other changes to its semiconductor products and services per JESD46C and to discontinue any product or service per JESD48B. Buyers should obtain the latest relevant information before placing orders and should verify that such information is current and complete. All semiconductor products (also referred to herein as "components") are sold subject to TI's terms and conditions of sale supplied at the time of order acknowledgment.

TI warrants performance of its components to the specifications applicable at the time of sale, in accordance with the warranty in TI's terms and conditions of sale of semiconductor products. Testing and other quality control techniques are used to the extent TI deems necessary to support this warranty. Except where mandated by applicable law, testing of all parameters of each component is not necessarily performed.

TI assumes no liability for applications assistance or the design of Buyers' products. Buyers are responsible for their products and applications using TI components. To minimize the risks associated with Buyers' products and applications, Buyers should provide adequate design and operating safeguards.

TI does not warrant or represent that any license, either express or implied, is granted under any patent right, copyright, mask work right, or other intellectual property right relating to any combination, machine, or process in which TI components or services are used. Information published by TI regarding third-party products or services does not constitute a license to use such products or services or a warranty or endorsement thereof. Use of such information may require a license from a third party under the patents or other intellectual property of the third party, or a license from TI under the patents or other intellectual property of TI.

Reproduction of significant portions of TI information in TI data books or data sheets is permissible only if reproduction is without alteration and is accompanied by all associated warranties, conditions, limitations, and notices. TI is not responsible or liable for such altered documentation. Information of third parties may be subject to additional restrictions.

Resale of TI components or services with statements different from or beyond the parameters stated by TI for that component or service voids all express and any implied warranties for the associated TI component or service and is an unfair and deceptive business practice. TI is not responsible or liable for any such statements.

Buyer acknowledges and agrees that it is solely responsible for compliance with all legal, regulatory and safety-related requirements concerning its products, and any use of TI components in its applications, notwithstanding any applications-related information or support that may be provided by TI. Buyer represents and agrees that it has all the necessary expertise to create and implement safeguards which anticipate dangerous consequences of failures, monitor failures and their consequences, lessen the likelihood of failures that might cause harm and take appropriate remedial actions. Buyer will fully indemnify TI and its representatives against any damages arising out of the use of any TI components in safety-critical applications.

In some cases, TI components may be promoted specifically to facilitate safety-related applications. With such components, TI's goal is to help enable customers to design and create their own end-product solutions that meet applicable functional safety standards and requirements. Nonetheless, such components are subject to these terms.

No TI components are authorized for use in FDA Class III (or similar life-critical medical equipment) unless authorized officers of the parties have executed a special agreement specifically governing such use.

Only those TI components which TI has specifically designated as military grade or "enhanced plastic" are designed and intended for use in military/aerospace applications or environments. Buyer acknowledges and agrees that any military or aerospace use of TI components which have **not** been so designated is solely at the Buyer's risk, and that Buyer is solely responsible for compliance with all legal and regulatory requirements in connection with such use.

TI has specifically designated certain components which meet ISO/TS16949 requirements, mainly for automotive use. Components which have not been so designated are neither designed nor intended for automotive use; and TI will not be responsible for any failure of such components to meet such requirements.

Products

Audio	www.ti.com/audio
Amplifiers	amplifier.ti.com
Data Converters	dataconverter.ti.com
DLP® Products	www.dlp.com
DSP	dsp.ti.com
Clocks and Timers	www.ti.com/clocks
Interface	interface.ti.com
Logic	logic.ti.com
Power Mgmt	power.ti.com
Microcontrollers	microcontroller.ti.com
RFID	www.ti-rfid.com
OMAP Mobile Processors	www.ti.com/omap
Wireless Connectivity	www.ti.com/wirelessconnectivity

Applications

Automotive and Transportation	www.ti.com/automotive
Communications and Telecom	www.ti.com/communications
Computers and Peripherals	www.ti.com/computers
Consumer Electronics	www.ti.com/consumer-apps
Energy and Lighting	www.ti.com/energy
Industrial	www.ti.com/industrial
Medical	www.ti.com/medical
Security	www.ti.com/security
Space, Avionics and Defense	www.ti.com/space-avionics-defense
Video and Imaging	www.ti.com/video

TI E2E Community e2e.ti.com