



# Dual, VARIABLE GAIN AMPLIFIER with Low Noise Preamp

## FEATURES

- **LOW NOISE PREAMP:**
  - Low Input Noise:  $1.25\text{nV}/\sqrt{\text{Hz}}$
  - Active Termination Noise Reduction
  - Switchable Termination Value
  - 80MHz Bandwidth
  - 5dB to 25dB Gain Range
  - Differential Input/Output
- **LOW NOISE VARIABLE GAIN AMPLIFIER:**
  - Low Noise VCA:  $3.3\text{nV}/\sqrt{\text{Hz}}$ , Differential Programming Optimizes Noise Figure
  - 24dB to 45dB Gain
  - 40MHz Bandwidth
  - Differential Input/Output
- **LOW CROSSTALK:** 52dB at Max Gain, 5MHz
- **HIGH-SPEED VARIABLE GAIN ADJUST**
- **SWITCHABLE EXTERNAL PROCESSING**

## APPLICATIONS

- **ULTRASOUND SYSTEMS**
- **WIRELESS RECEIVERS**
- **TEST EQUIPMENT**

## DESCRIPTION

The VCA2612 is a highly integrated, dual receive channel, signal processing subsystem. Each channel of the product consists of a low noise preamplifier (LNP) and a Variable Gain Amplifier (VGA). The LNP circuit provides the necessary connections to implement Active Termination (AT), a method of cable termination which results in up to 4.6dB noise figure improvement. Different cable termination characteristics can be accommodated by utilizing the VCA2612's switchable LNA feedback pins. The LNP has the ability to accept both differential and single-ended inputs, and generates a differential output signal. The LNP provides strappable gains of 5dB, 17dB, 22dB, and 25dB.

The output of the LNP can be accessed externally for further signal processing, or fed directly into the VGA. The VCA2612's VGA section consists of two parts: the Voltage Controlled Attenuator (VCA) and the Programmable Gain Amplifier (PGA). The gain and gain range of the PGA can be digitally programmed. The combination of these two programmable elements results in a variable gain ranging from 0dB up to a maximum gain as defined by the user through external connections. The output of the VGA can be used in either a single-ended or differential mode to drive high-performance Analog-to-Digital (A/D) converters.

The VCA2612 also features low crosstalk and outstanding distortion performance. The combination of low noise and gain range programmability make the VCA2612 a versatile building block in a number of applications where noise performance is critical. The VCA2612 is available in a TQFP-48 package.

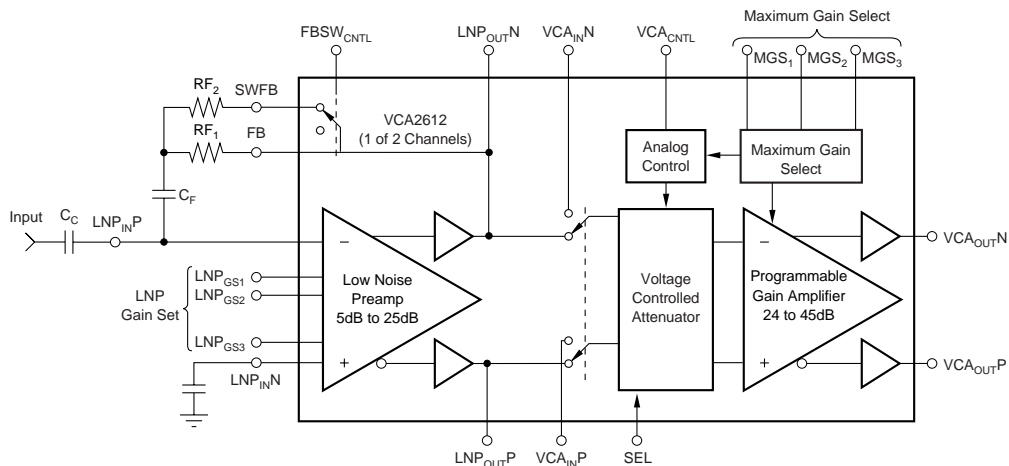

Please be aware that an important notice concerning availability, standard warranty, and use in critical applications of Texas Instruments semiconductor products and disclaimers thereto appears at the end of this data sheet.

All trademarks are the property of their respective owners.

PRODUCTION DATA information is current as of publication date. Products conform to specifications per the terms of Texas Instruments standard warranty. Production processing does not necessarily include testing of all parameters.



Copyright © 2000-2004, Texas Instruments Incorporated

## ABSOLUTE MAXIMUM RATINGS<sup>(1)</sup>

|                                 |                                   |
|---------------------------------|-----------------------------------|
| Power Supply (+V <sub>S</sub> ) | +6V                               |
| Analog Input                    | -0.3V to (+V <sub>S</sub> + 0.3V) |
| Logic Input                     | -0.3V to (+V <sub>S</sub> + 0.3V) |
| Case Temperature                | +100°C                            |
| Junction Temperature            | +150°C                            |
| Storage Temperature             | -40°C to +150°C                   |

NOTE: (1) Stresses above these ratings may cause permanent damage. Exposure to absolute maximum conditions for extended periods may degrade device reliability.



## ELECTROSTATIC DISCHARGE SENSITIVITY

This integrated circuit can be damaged by ESD. Texas Instruments recommends that all integrated circuits be handled with appropriate precautions. Failure to observe proper handling and installation procedures can cause damage.

ESD damage can range from subtle performance degradation to complete device failure. Precision integrated circuits may be more susceptible to damage because very small parametric changes could cause the device not to meet its published specifications.

## PACKAGE/ORDERING INFORMATION<sup>(1)</sup>

| PRODUCT  | PACKAGE-LEAD | PACKAGE DESIGNATOR | PACKAGE MARKING | ORDERING NUMBER | TRANSPORT MEDIA, QUANTITY |
|----------|--------------|--------------------|-----------------|-----------------|---------------------------|
| VCA2612Y | TQFP-48      | PFB                | VCA2612Y        | VCA2612Y/250    | Tape and Reel, 250        |
| "        | "            | "                  | "               | VCA2612Y/2K     | Tape and Reel, 2000       |

NOTE: (1) For the most current package and ordering information, see the Package Option Addendum located at the end of this data sheet.

## ELECTRICAL CHARACTERISTICS

At T<sub>A</sub> = +25°C, V<sub>DDA</sub> = V<sub>DDB</sub> = V<sub>DDR</sub> = +5V, load resistance = 500Ω on each output to ground, MGS = 011, LNP = 22dB and f<sub>IN</sub> = 5MHz, unless otherwise noted. The input to the preamp (LNP) is single-ended, and the output from the VCA is single-ended unless otherwise noted.

| PARAMETER  | CONDITIONS   | VCA2612Y |            |                   | UNITS            |
|--|--|----------|------------|-------------------|------------------|
|  |  | MIN      | TYP        | MAX               |                  |
| <b>PREAMPLIFIER</b>  |  |          |            |                   |                  |
| Input Resistance   |  |          | 600        |                   | kΩ               |
| Input Capacitance  |  |          | 15         |                   | pF               |
| Input Bias Current   |  |          | 1          |                   | nA               |
| CMRR   | f = 1MHz, VCA <sub>CNTL</sub> = 0.2V                                       |          | 50         |                   | dB               |
| Maximum Input Voltage  | Preamp Gain = +5dB   |          | 1          |                   | V <sub>PP</sub>  |
|  | Preamp Gain = +25dB  |          | 112        |                   | mV <sub>PP</sub> |
| Input Voltage Noise <sup>(1)</sup>                                       | Preamp Gain = +5dB   |          | 3.5        |                   | nV/√Hz           |
|  | Preamp Gain = +25dB  |          | 1.25       |                   | nV/√Hz           |
| Input Current Noise  | Independent of Gain  |          | 0.35       |                   | pA/√Hz           |
| Noise Figure, R <sub>S</sub> = 75Ω, R <sub>IN</sub> = 75Ω <sup>(1)</sup> | R <sub>F</sub> = 550Ω, Preamp Gain = 22dB,<br>PGA Gain = 39dB              |          | 6.2        |                   | dB               |
| Bandwidth  | Gain = 22dB  |          | 80         |                   | MHz              |
| <b>PROGRAMMABLE VARIABLE GAIN AMPLIFIER</b>                              |  |          |            |                   |                  |
| Peak Input Voltage   | Differential   |          | 2          |                   | V <sub>PP</sub>  |
| -3dB Bandwidth   |  |          | 40         |                   | MHz              |
| Slew Rate  |  |          | 300        |                   | V/μs             |
| Output Signal Range  | R <sub>L</sub> ≥ 500Ω Each Side to Ground                                  |          | 2          |                   | V <sub>PP</sub>  |
| Output Impedance   | f = 5MHz   |          | 1          |                   | Ω                |
| Output Short-Circuit Current   |  |          | ±40        |                   | mA               |
| Third Harmonic Distortion  | f = 5MHz, V <sub>OUT</sub> = 1V <sub>PP</sub> , VCA <sub>CNTL</sub> = 3.0V | -45      | -71        |                   | dBc              |
| Second Harmonic Distortion   | f = 5MHz, V <sub>OUT</sub> = 1V <sub>PP</sub> , VCA <sub>CNTL</sub> = 3.0V | -45      | -63        |                   | dBc              |
| IMD, Two-Tone  | V <sub>OUT</sub> = 2V <sub>PP</sub> , f = 1MHz                             |          | -80        |                   | dBc              |
|  | V <sub>OUT</sub> = 2V <sub>PP</sub> , f = 10MHz                            |          | -80        |                   | dBc              |
| 1dB Compression Point  | f = 5MHz, Output Referred, Differential                                    |          | 6          |                   | V <sub>PP</sub>  |
| Crosstalk  | V <sub>OUT</sub> = 1V <sub>PP</sub> , f = 1MHz, Max Gain Both Channels     |          | 68         |                   | dB               |
| Group Delay Variation  | 1MHz < f < 10MHz, Full Gain Range  |          | ±2         |                   | ns               |
| DC Output Level, V <sub>IN</sub> = 0                                     |  |          | 2.5        |                   | V                |
| <b>ACCURACY</b>  |  |          |            |                   |                  |
| Gain Slope   |  |          | 10.9       |                   | dB/V             |
| Gain Error   |  |          |            | ±1 <sup>(2)</sup> | dB               |
| Output Offset Voltage  |  |          | ±50        |                   | mV               |
| Total Gain   | VCA <sub>CNTL</sub> = 0.2V   | 18       | 21         | 24                | dB               |
|  | VCA <sub>CNTL</sub> = 3.0V   | 47       | 50         | 53                | dB               |
| <b>GAIN CONTROL INTERFACE</b>  |  |          |            |                   |                  |
| Input Voltage (VCA <sub>CNTL</sub> ) Range                               |  |          | 0.2 to 3.0 |                   | V                |
| Input Resistance   |  |          | 1          |                   | MΩ               |
| Response Time  | 45dB Gain Change, MGS = 111  |          | 0.2        |                   | μs               |
| <b>POWER SUPPLY</b>  |  |          |            |                   |                  |
| Operating Temperature Range  |  | -40      |            | +85               | °C               |
| Specified Operating Range  |  | 4.75     | 5.0        | 5.25              | V                |
| Power Dissipation  | Operating, Both Channels   |          | 410        | 495               | mW               |
| Thermal Resistance, θ <sub>JA</sub>                                      | TQFP-48  |          | 56.5       |                   | °C/W             |

NOTE: (1) For preamp driving VGA. (2) Referenced to best fit dB-linear curve.

## PIN CONFIGURATION

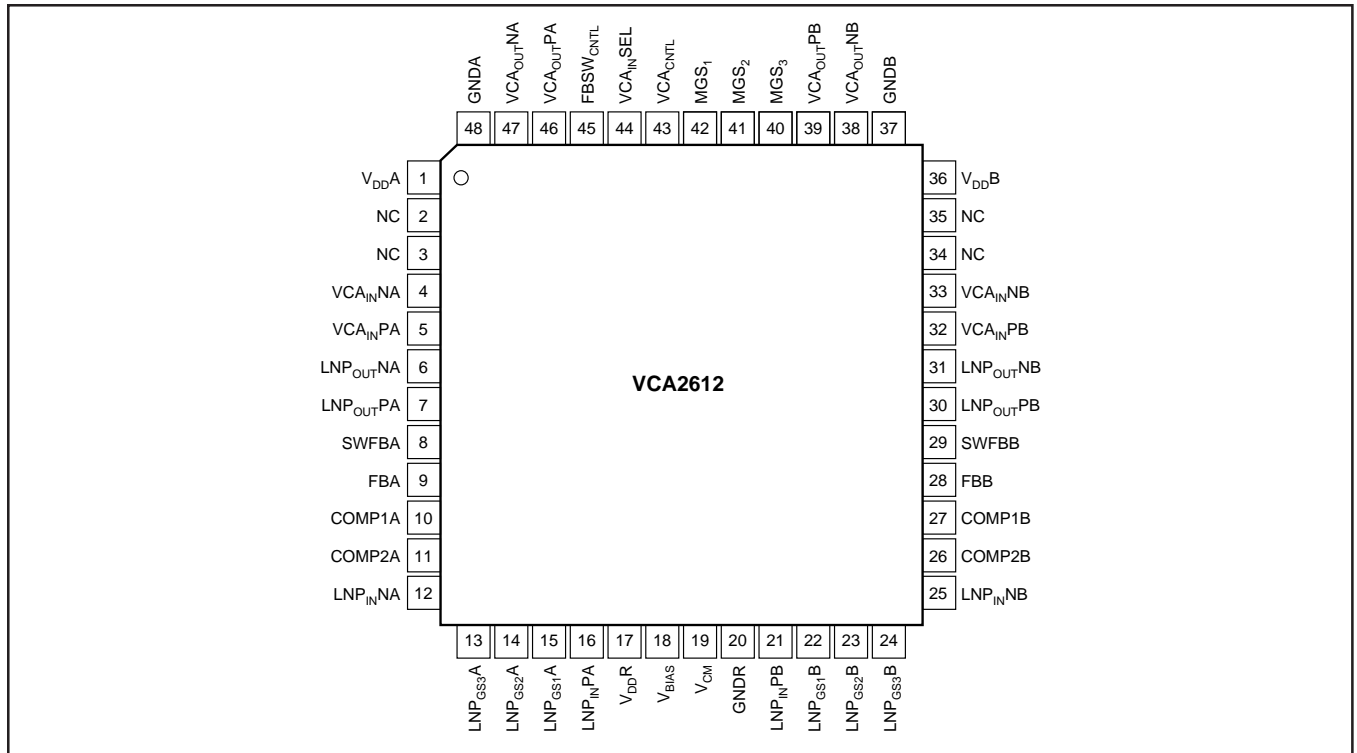

## PIN DESCRIPTIONS

| PIN | DESIGNATOR            | DESCRIPTION                          | PIN | DESIGNATOR            | DESCRIPTION                        |
|-----|-----------------------|--------------------------------------|-----|-----------------------|------------------------------------|
| 1   | V <sub>DD</sub> A     | Channel A +Supply (+5V)              | 25  | LNP <sub>IN</sub> NB  | Channel B LNP Inverting Input      |
| 2   | NC                    | Do Not Connect                       | 26  | COMP2B                | Channel B Frequency Compensation 2 |
| 3   | NC                    | Do Not Connect                       | 27  | COMP1B                | Channel B Frequency Compensation 1 |
| 4   | VCA <sub>IN</sub> NA  | Channel A VCA Negative Input         | 28  | FBB                   | Channel B Feedback Output          |
| 5   | VCA <sub>IN</sub> PA  | Channel A VCA Positive Input         | 29  | SWFBB                 | Channel B Switched Feedback Output |
| 6   | LNP <sub>OUT</sub> NA | Channel A LNP Negative Output        | 30  | LNP <sub>OUT</sub> PB | Channel B LNP Positive Output      |
| 7   | LNP <sub>OUT</sub> PA | Channel A LNP Positive Output        | 31  | LNP <sub>OUT</sub> NB | Channel B LNP Negative Output      |
| 8   | SWFBA                 | Channel A Switched Feedback Output   | 32  | VCA <sub>IN</sub> PB  | Channel B VCA Positive Input       |
| 9   | FBA                   | Channel A Feedback Output            | 33  | VCA <sub>IN</sub> NB  | Channel B VCA Negative Input       |
| 10  | COMP1A                | Channel A Frequency Compensation 1   | 34  | NC                    | Do Not Connect                     |
| 11  | COMP2A                | Channel A Frequency Compensation 2   | 35  | NC                    | Do Not Connect                     |
| 12  | LNP <sub>IN</sub> NA  | Channel A LNP Inverting Input        | 36  | V <sub>DD</sub> B     | Channel B +Analog Supply (+5V)     |
| 13  | LNP <sub>GS3</sub> A  | Channel A LNP Gain Strap 3           | 37  | GND B                 | Channel B Analog Ground            |
| 14  | LNP <sub>GS2</sub> A  | Channel A LNP Gain Strap 2           | 38  | VCA <sub>OUT</sub> NB | Channel B VCA Negative Output      |
| 15  | LNP <sub>GS1</sub> A  | Channel A LNP Gain Strap 1           | 39  | VCA <sub>OUT</sub> PB | Channel B VCA Positive Output      |
| 16  | LNP <sub>IN</sub> PA  | Channel A LNP Noninverting Input     | 40  | MGS <sub>3</sub>      | Maximum Gain Select 3 (LSB)        |
| 17  | V <sub>DD</sub> R     | +Supply for Internal Reference (+5V) | 41  | MGS <sub>2</sub>      | Maximum Gain Select 2              |
| 18  | V <sub>BIAS</sub>     | 0.01μF Bypass to Ground              | 42  | MGS <sub>1</sub>      | Maximum Gain Select 1 (MSB)        |
| 19  | V <sub>CM</sub>       | 0.01μF Bypass to Ground              | 43  | VCA <sub>CNTL</sub>   | VCA Control Voltage                |
| 20  | GNDR                  | Ground for Internal Reference        | 44  | VCA <sub>IN</sub> SEL | VCA Input Select, HI = External    |
| 21  | LNP <sub>IN</sub> PB  | Channel B LNP Noninverting Input     | 45  | FBSW <sub>CNTL</sub>  | Feedback Switch Control: HI = ON   |
| 22  | LNP <sub>GS1</sub> B  | Channel B LNP Gain Strap 1           | 46  | VCA <sub>OUT</sub> PA | Channel A VCA Positive Output      |
| 23  | LNP <sub>GS2</sub> B  | Channel B LNP Gain Strap 2           | 47  | VCA <sub>OUT</sub> NA | Channel A VCA Negative Output      |
| 24  | LNP <sub>GS3</sub> B  | Channel B LNP Gain Strap 3           | 48  | GND A                 | Channel A Analog Ground            |

# TYPICAL CHARACTERISTICS

At  $T_A = +25^\circ\text{C}$ ,  $V_{DDA} = V_{DDB} = V_{DDR} = +5\text{V}$ , load resistance =  $500\Omega$  on each output to ground,  $\text{MGS} = 011$ ,  $\text{LNP} = 22\text{dB}$  and  $f_{\text{IN}} = 5\text{MHz}$ , unless otherwise noted. The input to the preamp (LNP) is single-ended, and the output from the VCA is single-ended unless otherwise noted. This results in a 6dB reduction in signal amplitude compared to differential operation.

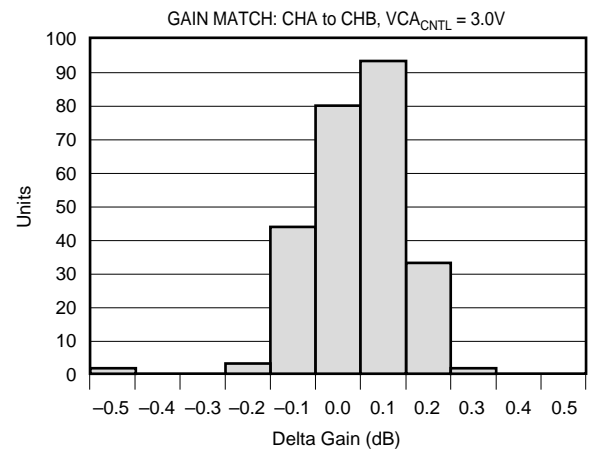
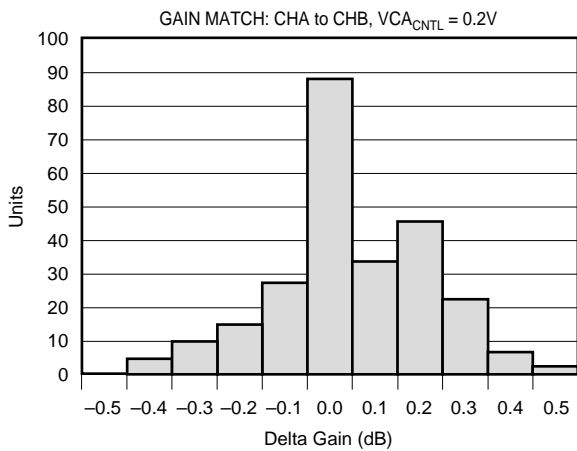
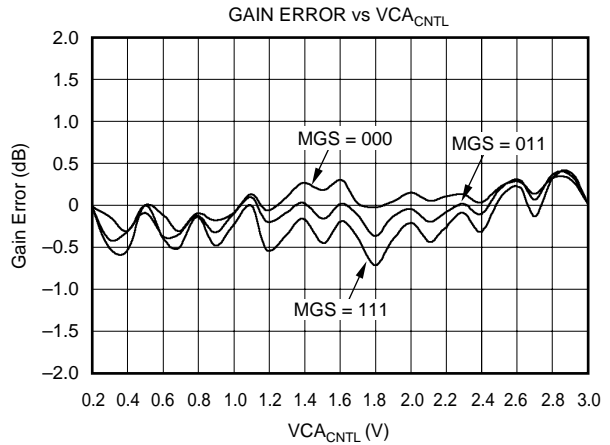
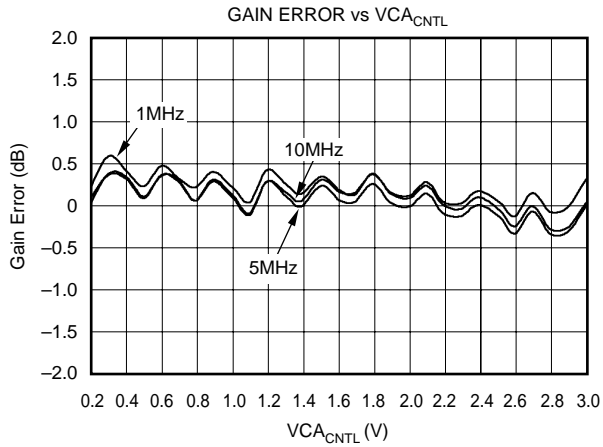
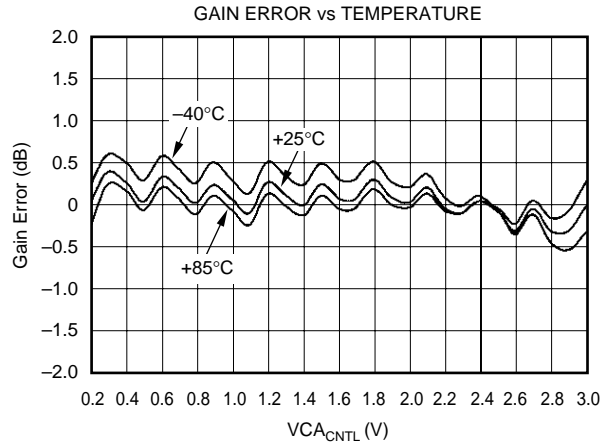
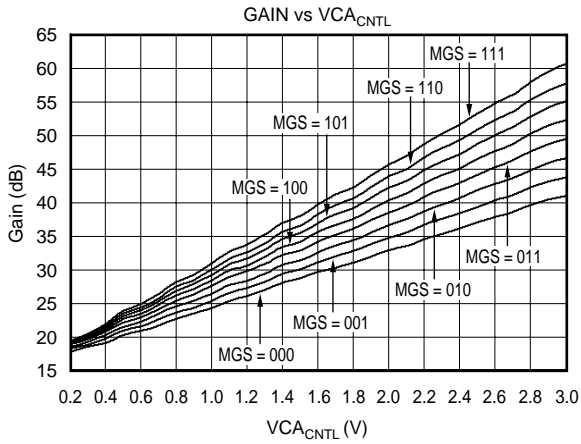

# TYPICAL CHARACTERISTICS (Cont.)

At  $T_A = +25^\circ\text{C}$ ,  $V_{DDA} = V_{DDB} = V_{DDR} = +5\text{V}$ , load resistance =  $500\Omega$  on each output to ground,  $\text{MGS} = 011$ ,  $\text{LNP} = 22\text{dB}$  and  $f_{\text{IN}} = 5\text{MHz}$ , unless otherwise noted. The input to the preamp (LNP) is single-ended, and the output from the VCA is single-ended unless otherwise noted. This results in a 6dB reduction in signal amplitude compared to differential operation.

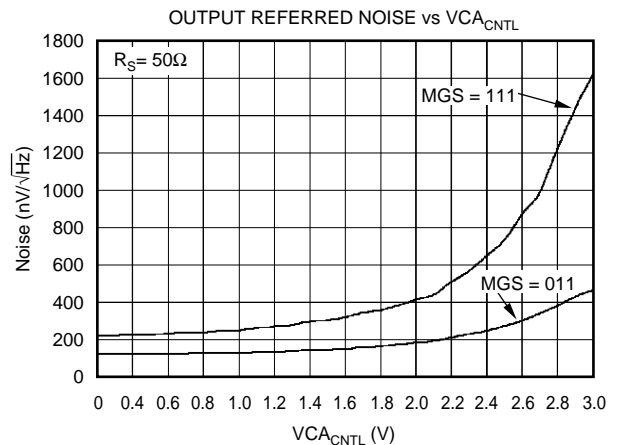
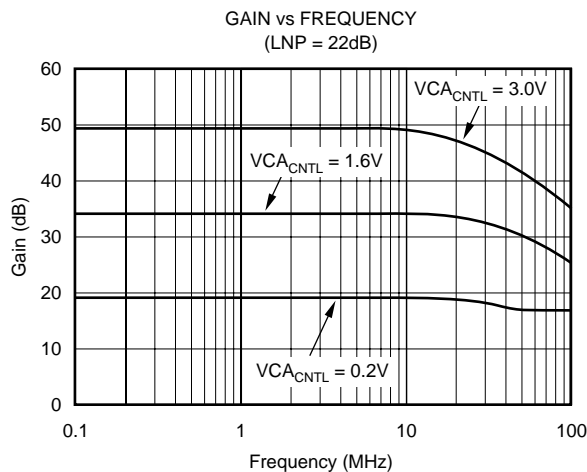
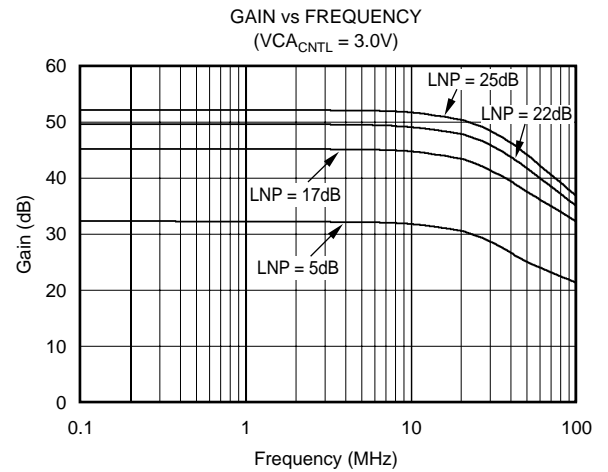
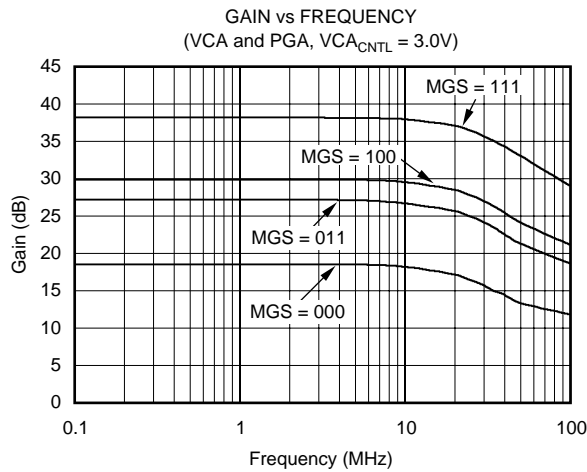
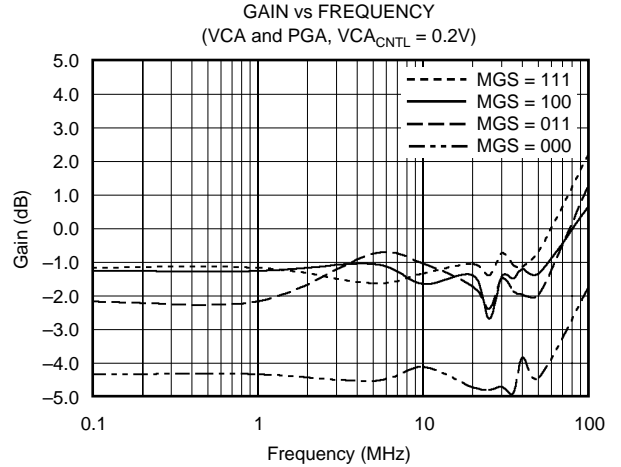
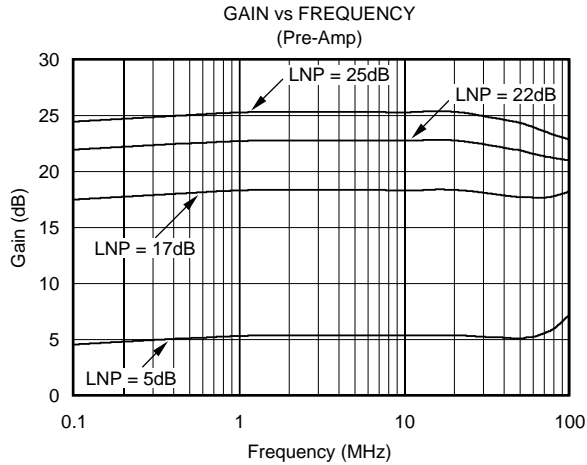

# TYPICAL CHARACTERISTICS (Cont.)

At  $T_A = +25^\circ\text{C}$ ,  $V_{DDA} = V_{DDB} = V_{DDR} = +5\text{V}$ , load resistance =  $500\Omega$  on each output to ground,  $\text{MGS} = 011$ ,  $\text{LNP} = 22\text{dB}$  and  $f_{\text{IN}} = 5\text{MHz}$ , unless otherwise noted. The input to the preamp (LNP) is single-ended, and the output from the VCA is single-ended unless otherwise noted. This results in a 6dB reduction in signal amplitude compared to differential operation.

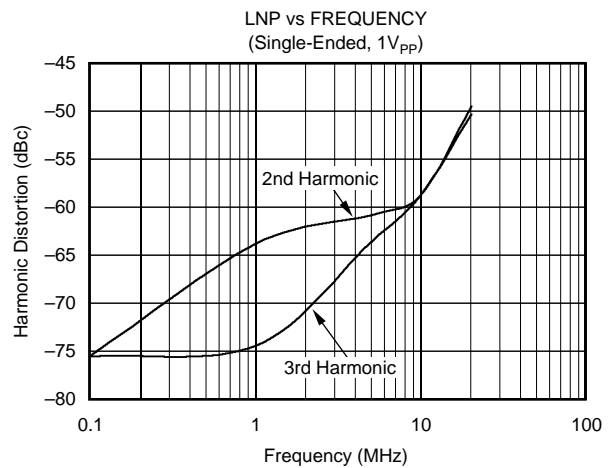
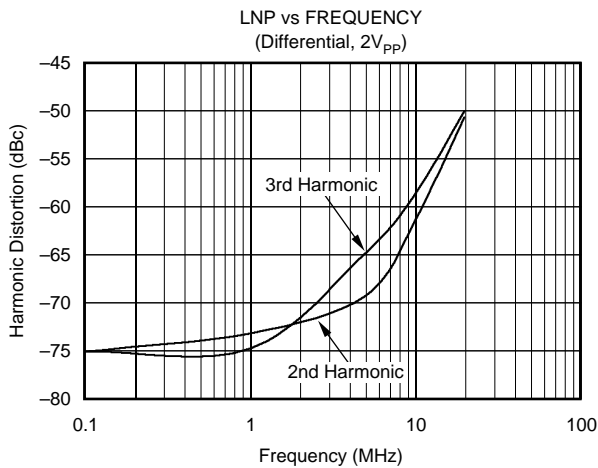
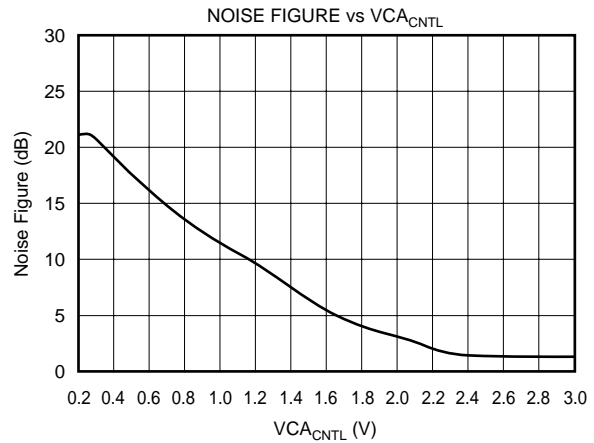
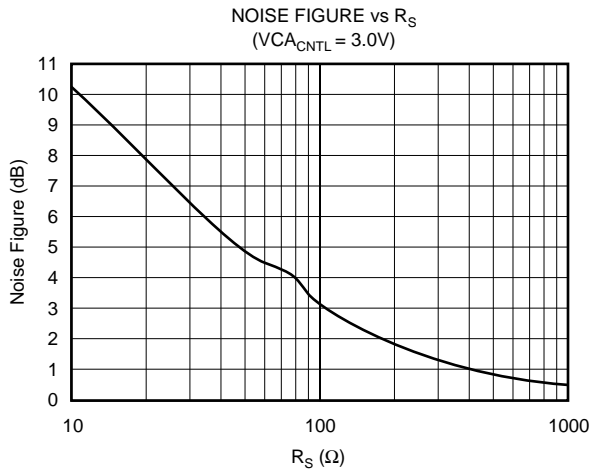
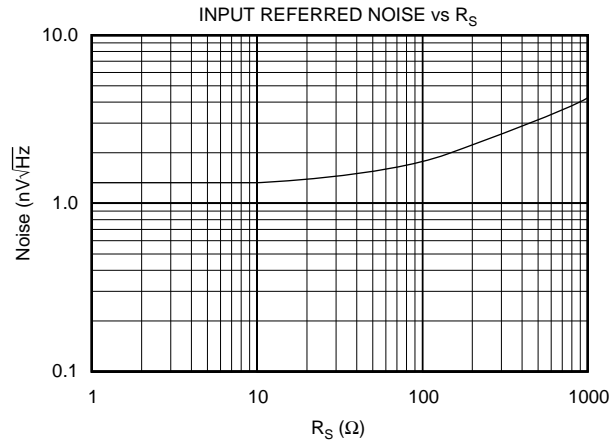
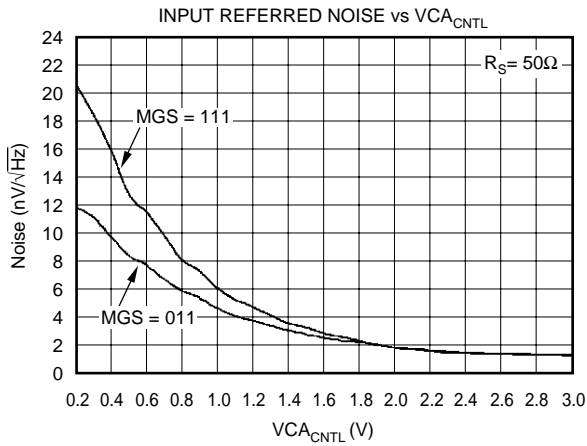

# TYPICAL CHARACTERISTICS (Cont.)

At  $T_A = +25^\circ\text{C}$ ,  $V_{DDA} = V_{DDB} = V_{DDR} = +5\text{V}$ , load resistance =  $500\Omega$  on each output to ground,  $\text{MGS} = 011$ ,  $\text{LNP} = 22\text{dB}$  and  $f_{\text{IN}} = 5\text{MHz}$ , unless otherwise noted. The input to the preamp (LNP) is single-ended, and the output from the VCA is single-ended unless otherwise noted. This results in a 6dB reduction in signal amplitude compared to differential operation.

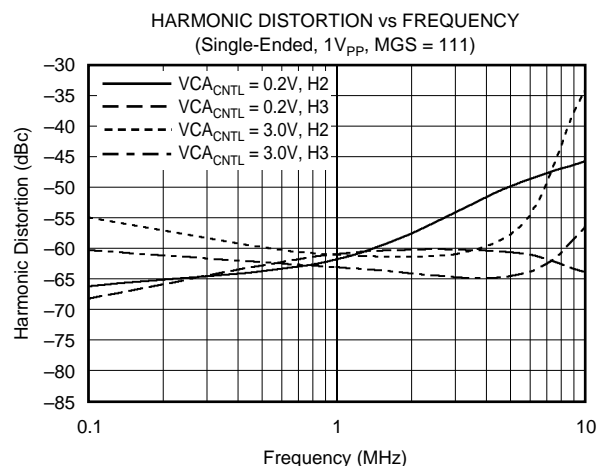
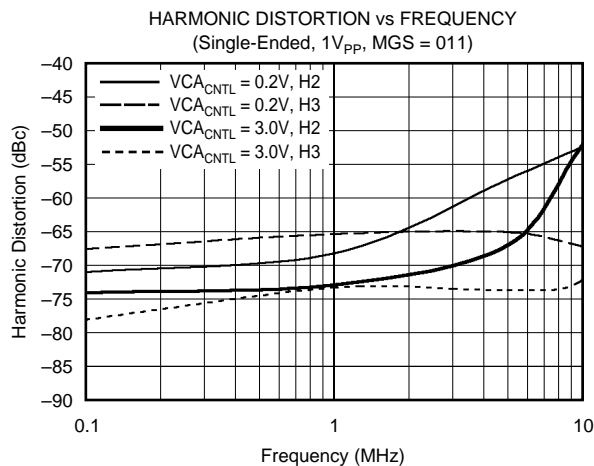
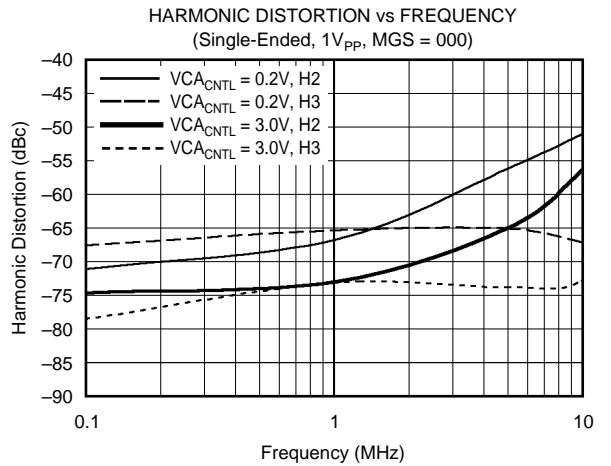
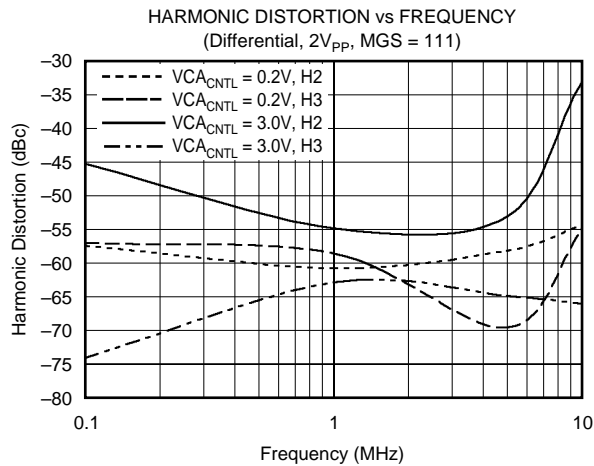
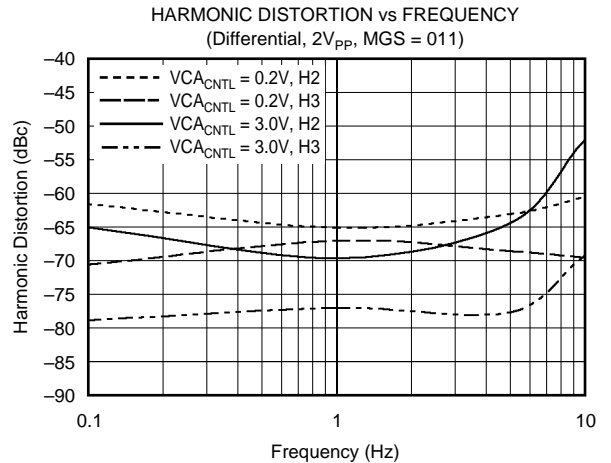
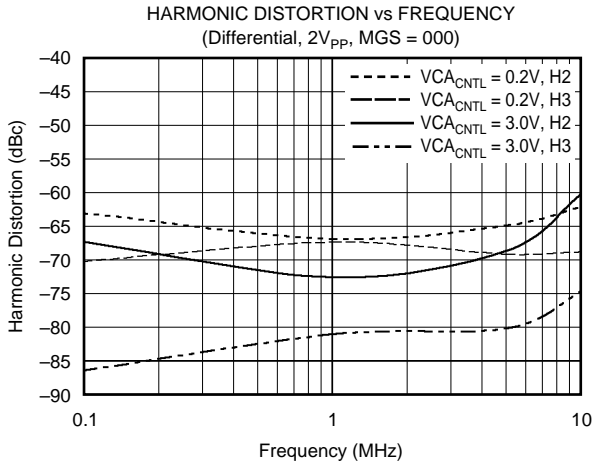

# TYPICAL CHARACTERISTICS (Cont.)

At  $T_A = +25^\circ\text{C}$ ,  $V_{DDA} = V_{DDB} = V_{DDR} = +5\text{V}$ , load resistance =  $500\Omega$  on each output to ground, MGS = 011, LNP = 22dB and  $f_{IN} = 5\text{MHz}$ , unless otherwise noted. The input to the preamp (LNP) is single-ended, and the output from the VCA is single-ended unless otherwise noted. This results in a 6dB reduction in signal amplitude compared to differential operation.

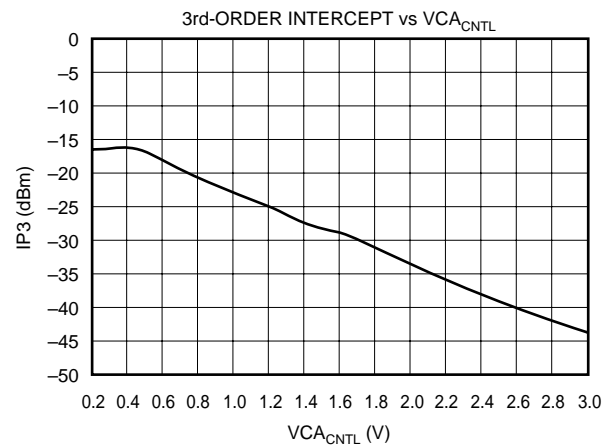
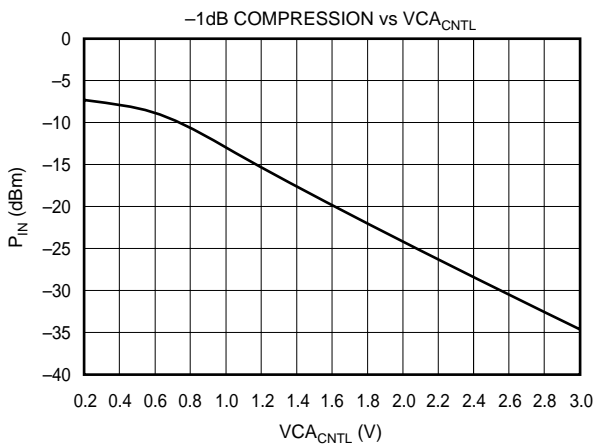
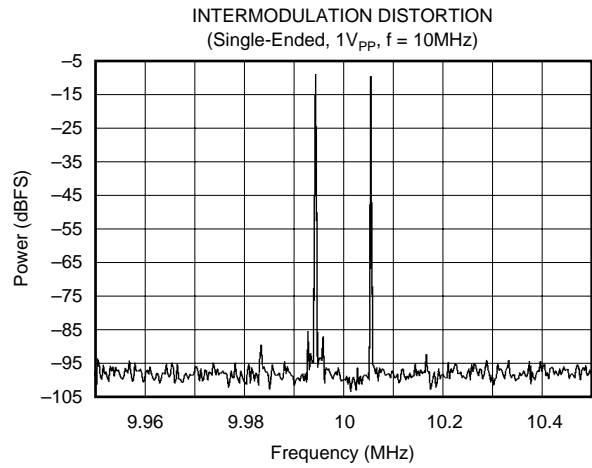
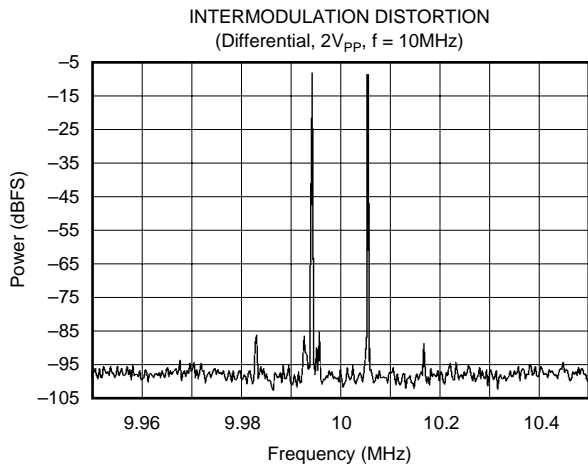
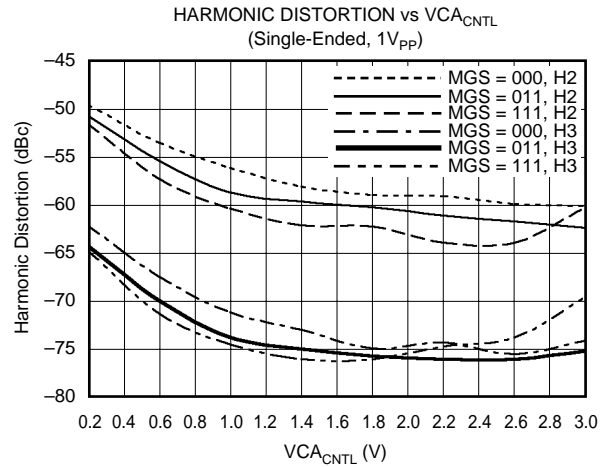
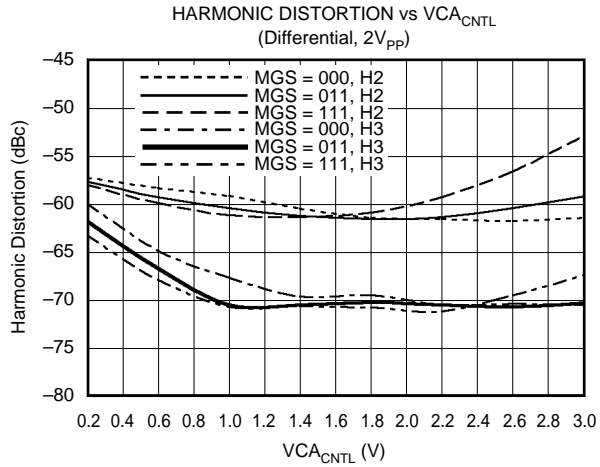

# TYPICAL CHARACTERISTICS (Cont.)

At  $T_A = +25^\circ\text{C}$ ,  $V_{DDA} = V_{DDB} = V_{DDR} = +5\text{V}$ , load resistance =  $500\Omega$  on each output to ground,  $\text{MGS} = 011$ ,  $\text{LNP} = 22\text{dB}$  and  $f_{\text{IN}} = 5\text{MHz}$ , unless otherwise noted. The input to the preamp (LNP) is single-ended, and the output from the VCA is single-ended unless otherwise noted. This results in a 6dB reduction in signal amplitude compared to differential operation.

**PULSE RESPONSE (BURSTS)**  
(Differential,  $V_{\text{CA\_CNTRL}} = 3.0\text{V}$ ,  $\text{MGS} = 111$ )

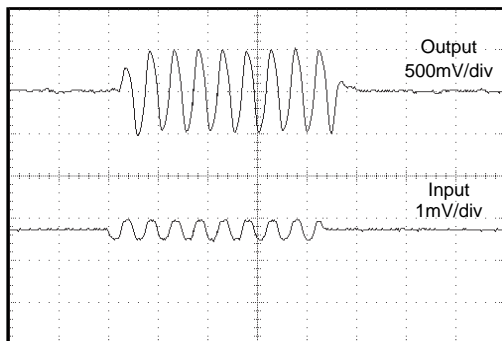

200ns/div

**OVERLOAD RECOVERY**  
(Differential,  $V_{\text{CA\_CNTRL}} = 3.0\text{V}$ ,  $\text{MGS} = 111$ )

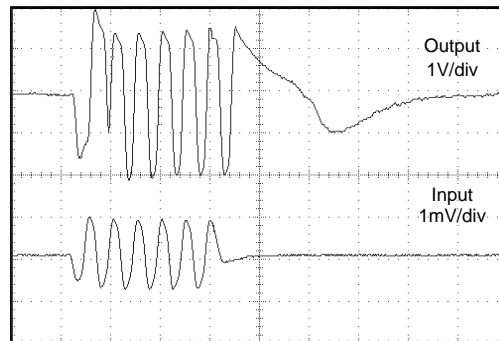

200ns/div

**GAIN RESPONSE**  
(Differential,  $V_{\text{CA\_CNTRL}}$  Pulsed,  $\text{MGS} = 111$ )

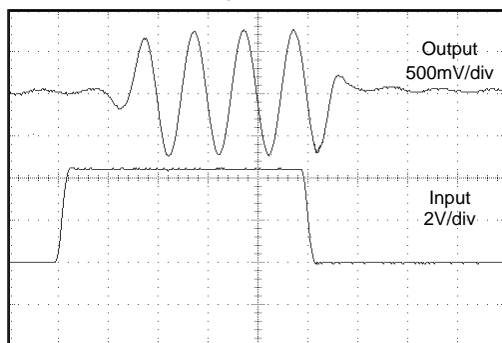

100ns/div

**CROSS TALK vs FREQUENCY**  
(Single-Ended, 1Vp-p,  $\text{MGS} = 011$ )

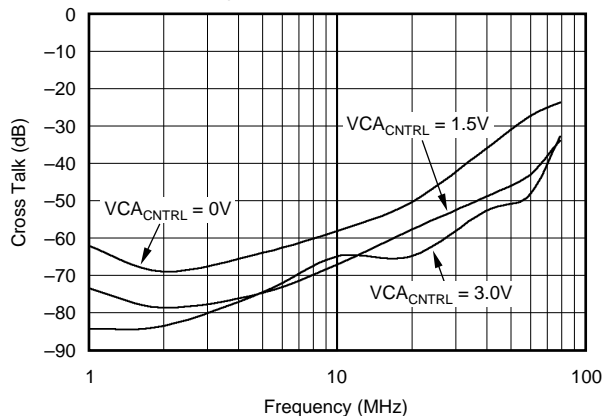

**CMRR vs FREQUENCY**  
(VCA only)

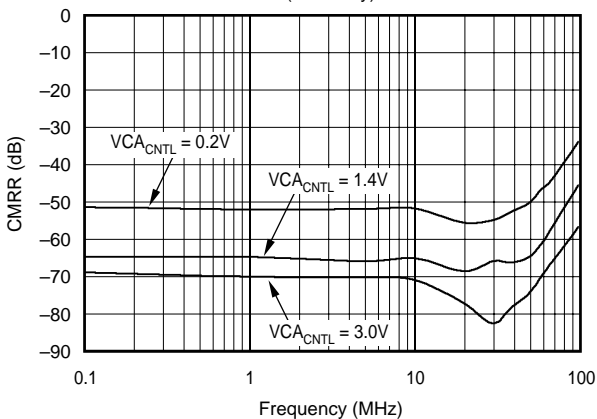

**CMRR vs FREQUENCY**  
(LNP only)

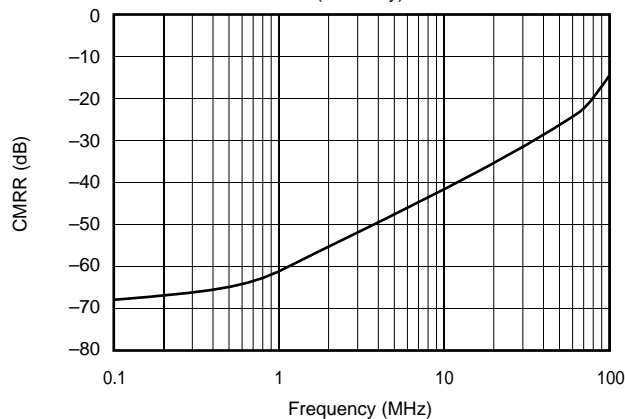

# TYPICAL CHARACTERISTICS (Cont.)

At  $T_A = +25^\circ\text{C}$ ,  $V_{DDA} = V_{DDB} = V_{DDR} = +5\text{V}$ , load resistance =  $500\Omega$  on each output to ground,  $MGS = 011$ ,  $LNP = 22\text{dB}$  and  $f_{IN} = 5\text{MHz}$ , unless otherwise noted. The input to the preamp (LNP) is single-ended, and the output from the VCA is single-ended unless otherwise noted. This results in a 6dB reduction in signal amplitude compared to differential operation.

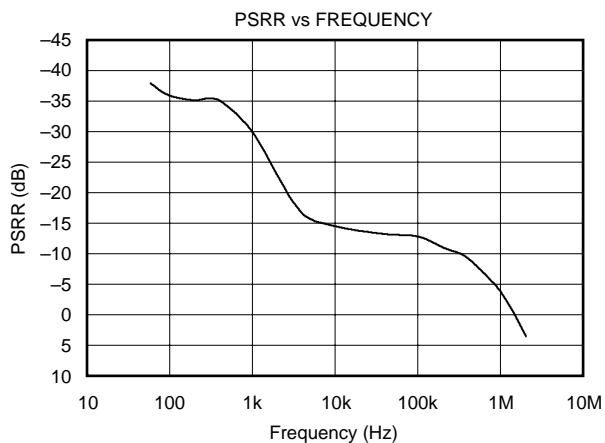
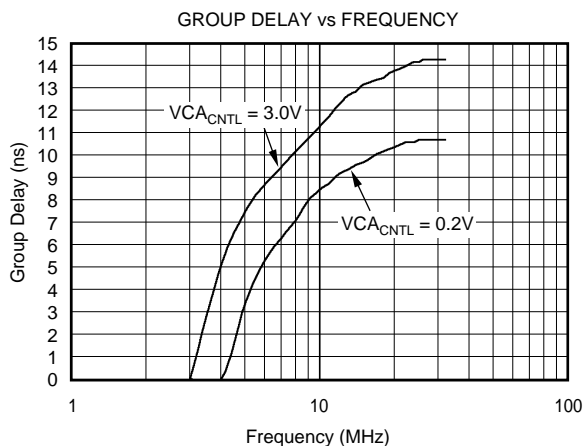
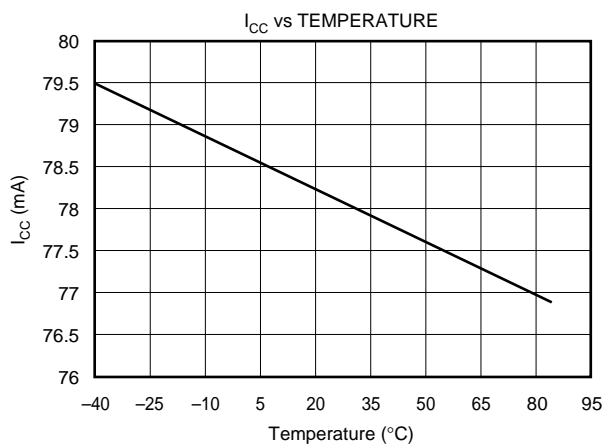

# THEORY OF OPERATION

The VCA2612 is a dual-channel system consisting of three primary blocks: a Low Noise Preamplifier (LNP), a Voltage Controlled Attenuator (VCA), and a Programmable Gain Amplifier (PGA). For greater system flexibility, an onboard multiplexer is provided for the VCA inputs, selecting either the LNP outputs or external signal inputs. Figure 1 shows a simplified block diagram of the dual-channel system.

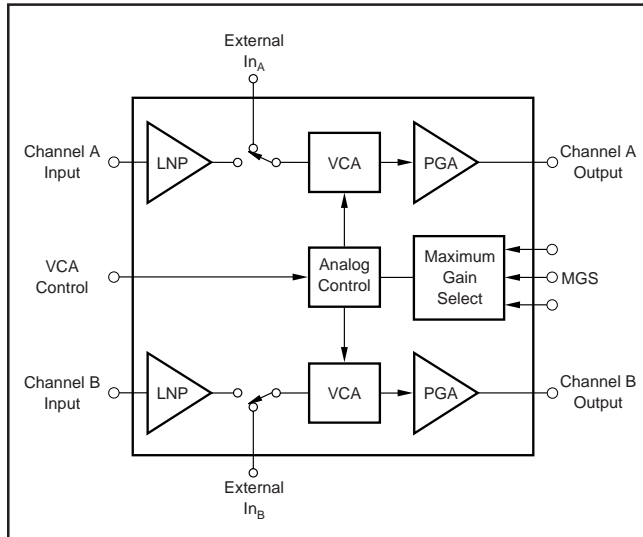

FIGURE 1. Simplified Block Diagram of the VCA2612.

## LNP—OVERVIEW

The LNP input may be connected to provide active-feedback signal termination, achieving lower system noise performance than conventional passive shunt termination. Even lower noise performance is obtained if signal termination is not required. The unterminated LNP input impedance is 600kΩ. The LNP can process fully differential or single-ended signals in each channel. Differential signal processing results in significantly reduced 2nd-harmonic distortion and improved rejection of common-mode and power supply noise. The first gain stage of the LNP is AC-coupled into its output buffer with a 44μs time constant (3.6kHz high-pass characteristic). The buffered LNP outputs are designed to drive the succeeding VCA directly or, if desired, external loads as low as 135Ω with minimal impact on signal distortion. The LNP employs very low impedance local feedback to achieve stable gain with the lowest possible noise and distortion. Four pin-programmable gain settings are available: 5dB, 17dB, 22dB, and 25dB. Additional intermediate gains can be programmed by adding trim resistors between the Gain Strap programming pins.

The common-mode DC level at the LNP output is nominally 2.5V, matching the input common-mode requirement of the VCA for simple direct coupling. When external signals are fed to the VCA, they should also be set up with a 2.5VDC common-mode level. Figure 2 shows a circuit that demonstrates the recommended coupling method using an external

op amp. The  $V_{CM}$  node shown in the drawing is the  $V_{CM}$  output (pin 19). Typical R and C values are shown, yielding a high-pass time constant similar to that of the LNP. If a different common-mode referencing method is used, it is important that the common-mode level be within 10mV of the  $V_{CM}$  output for proper operation.

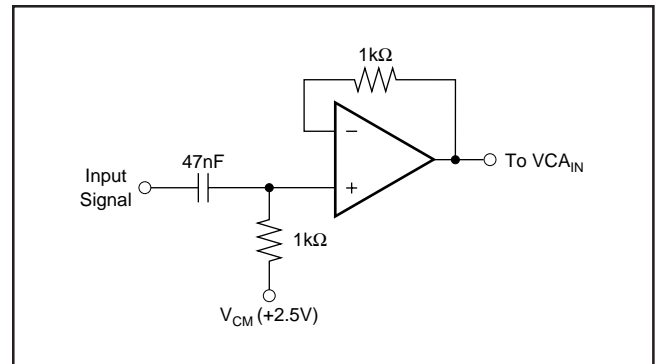

FIGURE 2. Recommended Circuit for Coupling an External Signal into the VCA Inputs.

## VCA—OVERVIEW

The magnitude of the differential VCA input signal (from the LNP or an external source) is reduced by a programmable attenuation factor, set by the analog VCA Control Voltage ( $V_{CA\_CNTL}$ ) at pin 43. The maximum attenuation factor is further programmable by using the three MGS bits (pins 40-42). Figure 3 illustrates this dual-adjustable characteristic. Internally, the signal is attenuated by having the analog  $V_{CA\_CNTL}$  vary the channel resistance of a set of shunt-connected FET transistors. The MGS bits effectively adjust the overall size of the shunt FET by switching parallel components in or out under logic control. At any given maximum gain setting, the analog variable gain characteristic is linear in dB as a function of the control voltage, and is created as a piecewise approximation of an ideal dB-linear transfer function. The VCA gain control circuitry is common to both channels of the VCA2612.

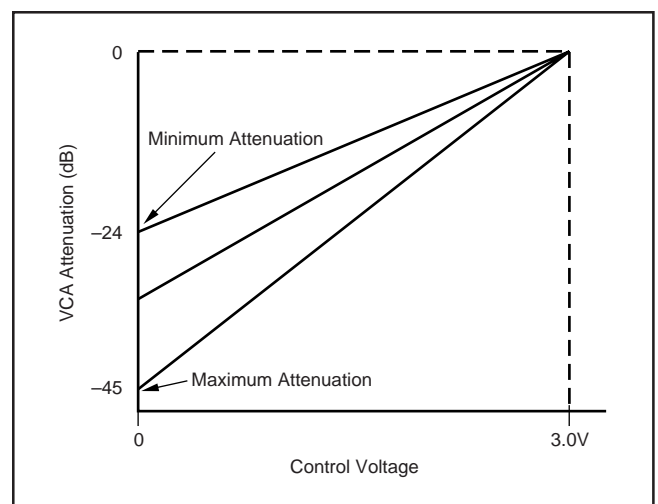

FIGURE 3. Swept Attenuator Characteristic.



where  $R_L$  is the load resistor in the drains of  $Q_3$  and  $Q_8$ , and  $R_S$  is the resistor connected between the sources of the input transistors  $Q_4$  and  $Q_7$ . The connections for various  $R_S$  combinations are brought out to device pins  $\text{LNPG}_{S1}$ ,  $\text{LNPG}_{S2}$ , and  $\text{LNPG}_{S3}$  (pins 13-15 for channel A, 22-24 for channel B). These Gain Strap pins allow the user to establish one of four fixed LNP gain options as shown in Table I.

| LNP PIN STRAPPING   | LNP GAIN (dB) |
|---|---------------|
| $\text{LNPG}_{S1}$ , $\text{LNPG}_{S2}$ , $\text{LNPG}_{S3}$ Connected Together | 25            |
| $\text{LNPG}_{S1}$ Connected to $\text{LNPG}_{S3}$                              | 22            |
| $\text{LNPG}_{S1}$ Connected to $\text{LNPG}_{S2}$                              | 17            |
| All Pins Open   | 5             |

TABLE I. Pin Strappings of the LNP for Various Gains.

It is also possible to create other gain settings by connecting an external resistor between  $\text{LNPG}_{S1}$  on one side, and  $\text{LNPG}_{S2}$  and/or  $\text{LNPG}_{S3}$  on the other. In that case, the internal resistor values shown in Figure 4 should be combined with the external resistor to calculate the effective value of  $R_S$  for use in Equation (1). The resulting expression for external resistor value is given in Equation (2).

$$R_{\text{EXT}} = \frac{2R_{S1}R_L + 2R_{\text{FIX}}R_L - \text{Gain} \cdot R_{S1}R_{\text{FIX}}}{\text{Gain} \cdot R_{S1} - 2R_L} \quad (2)$$

where  $R_{\text{EXT}}$  is the externally selected resistor value needed to achieve the desired gain setting,  $R_{S1}$  is the fixed parallel resistor in Figure 4, and  $R_{\text{FIX}}$  is the effective fixed value of the remaining internal resistors:  $R_{S2}$ ,  $R_{S3}$ , or  $(R_{S2} \parallel R_{S3})$  depending on the pin connections.

Note that the best process and temperature stability will be achieved by using the pre-programmed fixed gain options of Table I, since the gain is then set entirely by internal resistor ratios, which are typically accurate to  $\pm 0.5\%$ , and track quite well over process and temperature. When combining external resistors with the internal values to create an effective  $R_S$  value, note that the internal resistors have a typical temperature coefficient of  $+700\text{ppm}/^\circ\text{C}$  and an absolute value tolerance of approximately  $\pm 5\%$ , yielding somewhat less predictable and stable gain settings. With or without external resistors, the board layout should use short Gain Strap connections to minimize parasitic resistance and inductance effects.

The overall noise performance of the VCA2612 will vary as a function of gain. Table II shows the typical input- and output-referred noise densities of the entire VCA2612 for maximum VCA and PGA gain; i.e.,  $\text{VCA}_{\text{CNTL}}$  set to 3.0V and all MGS bits set to 1. Note that the input-referred noise values include the contribution of a  $50\Omega$  fixed source impedance, and are therefore somewhat larger than the intrinsic input noise. As the LNP gain is reduced, the noise contribution from the VCA/PGA portion becomes more significant, resulting in higher input-referred noise. However, the output-referred noise, which is indicative of the overall SNR at that gain setting, is reduced.

To preserve the low noise performance of the LNP, the user should take care to minimize resistance in the input lead. A parasitic resistance of only  $10\Omega$  will contribute  $0.4\text{nV}/\sqrt{\text{Hz}}$ .

| LNP GAIN (dB) | NOISE ( $\text{nV}/\sqrt{\text{Hz}}$ ) |                 |
|---------------|--|-----------------|
|               | Input-Referred                         | Output-Referred |
| 25            | 1.54                                   | 2260            |
| 22            | 1.59                                   | 1650            |
| 17            | 1.82                                   | 1060            |
| 5             | 4.07                                   | 597             |

TABLE II. Noise Performance for  $\text{MGS} = 111$  and  $\text{VCA}_{\text{CNTL}} = 3.0\text{V}$ .

The LNP is capable of generating a  $2V_{\text{PP}}$  differential signal. The maximum signal at the LNP input is therefore  $2V_{\text{PP}}$  divided by the LNP gain. An input signal greater than this would exceed the linear range of the LNP, an especially important consideration at low LNP gain settings.

### ACTIVE FEEDBACK WITH THE LNP

One of the key features of the LNP architecture is the ability to employ active-feedback termination to achieve superior noise performance. Active feedback termination achieves a lower noise figure than conventional shunt termination, essentially because no signal current is wasted in the termination resistor itself. Another way to understand this is as follows: Consider first that the input source, at the far end of the signal cable has a cable-matching source resistance of  $R_S$ . Using conventional shunt termination at the LNP input, a second terminating resistor of value  $R_S$  is connected to ground. Therefore, the signal loss is 6dB due to the voltage divider action of the series and shunt  $R_S$  resistors. The effective source resistance has been reduced by the same factor of 2, but the noise contribution has been reduced by only the  $\sqrt{2}$ , only a 3dB reduction. Therefore, the net theoretical SNR degradation is 3dB, assuming a noise-free amplifier input. (In practice, the amplifier noise contribution will degrade both the unterminated and the terminated noise figures, somewhat reducing the distinction between them.)

See Figure 5 for an amplifier using active feedback. This diagram appears very similar to a traditional inverting amplifier. However, the analysis is somewhat different because the gain  $A$  in this case is not a very large open-loop op amp gain; rather, it is the relatively low and controlled gain of the LNP itself. Thus, the impedance at the inverting amplifier terminal will be reduced by a finite amount, as given in the familiar relationship of Equation (3):

$$R_{\text{IN}} = \frac{R_F}{(1+A)} \quad (3)$$

where  $R_F$  is the feedback resistor (supplied externally between the  $\text{LNP}_{\text{INP}}$  and FB terminals for each channel),  $A$  is the user-selected gain of the LNP, and  $R_{\text{IN}}$  is the resulting amplifier input impedance with active feedback. In this case, unlike the conventional termination above, both the signal voltage and the  $R_S$  noise are attenuated by the same factor

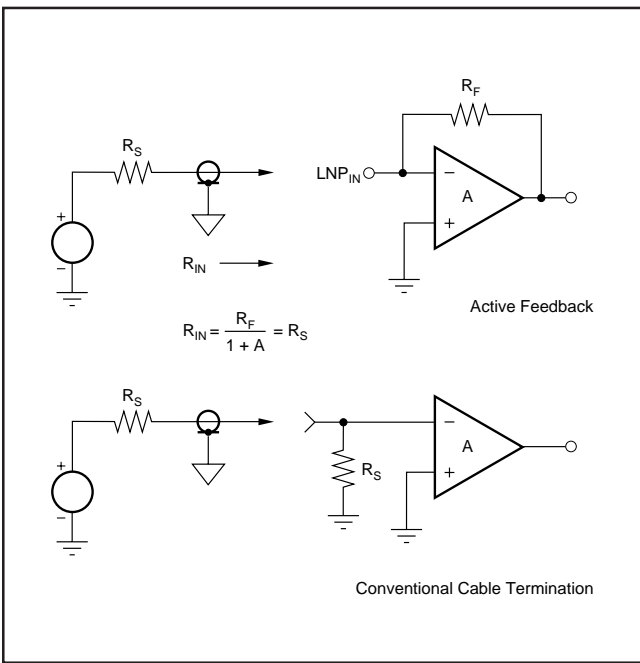

FIGURE 5. Configurations for Active Feedback and Conventional Cable Termination.

of two (6dB) before being re-amplified by the  $A$  gain setting. This avoids the extra 3dB degradation due to the square-root effect described above, the key advantage of the active termination technique.

As mentioned above, the previous explanation ignored the input noise contribution of the LNP itself. Also, the noise contribution of the feedback resistor must be included for a completely correct analysis. The curves given in Figures 6 and 7 allow the VCA2612 user to compare the achievable noise figure for active and conventional termination methods. The left-most set of data points in each graph give the results for typical 50Ω cable termination, showing the worst noise figure but also the greatest advantage of the active feedback method.

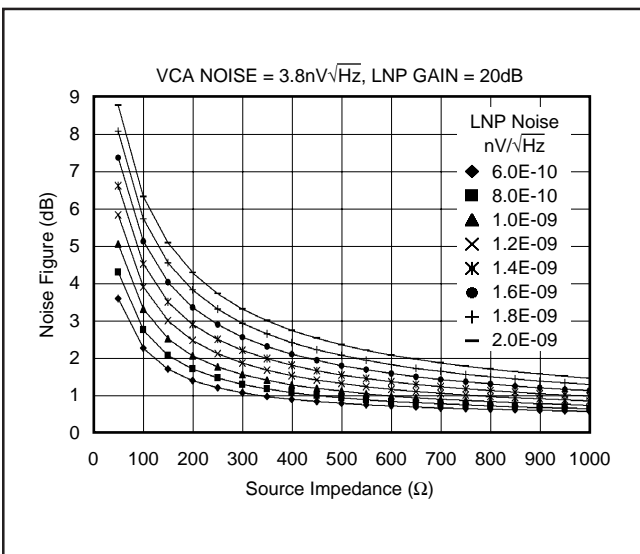

FIGURE 6. Noise Figure for Active Termination.

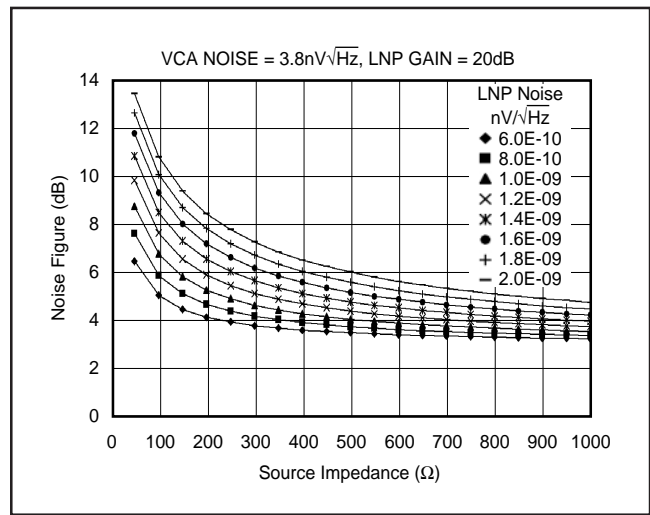

FIGURE 7. Noise Figure for Conventional Termination.

A switch, controlled by the  $FBSW_{CNTL}$  signal on pin 45, enables the user to reduce the feedback resistance by adding an additional parallel component, connected between the  $LNP_{INP}$  and  $SWFB$  terminals. The two different values of feedback resistance will result in two different values of active-feedback input resistance. Thus, the active-feedback impedance can be optimized at two different LNP gain settings. The switch is connected at the buffered output of the LNP and has an  $ON$  resistance of approximately 1Ω.

When employing active feedback, the user should be careful to avoid low-frequency instability or overload problems. Figure 8 illustrates the various low-frequency time constants. Referring again to the input resistance calculation of Equation (3), and considering that the gain term  $A$  falls off below 3.6kHz, it is evident that the effective LNP input impedance will rise below 3.6kHz, with a DC limit of approximately  $R_F$ . To avoid interaction with the feedback pole/zero at low frequencies, and to avoid the higher signal levels resulting from the rising impedance characteristic, it is recommended that the external  $R_F C_C$  time constant be set to about 5μs.

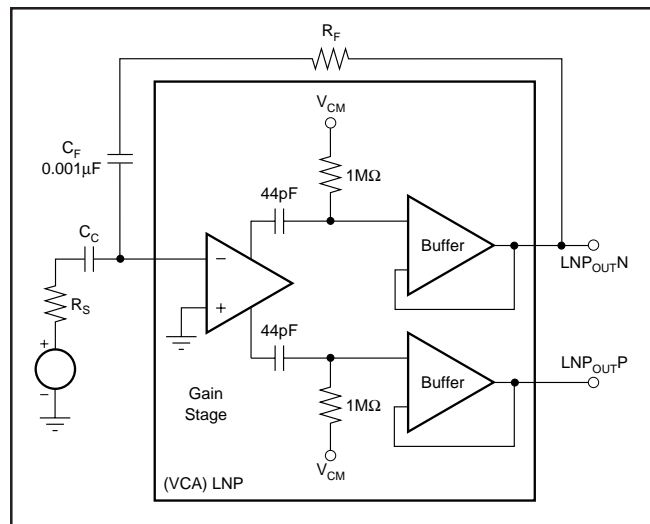

FIGURE 8. Low Frequency LNP Time Constants.

Achieving the best active feedback architecture is difficult with conventional op amp circuit structures. The overall gain  $A$  must be negative in order to close the feedback loop, the input impedance must be high to maintain low current noise and good gain accuracy, but the gain ratio must be set with very low value resistors to maintain good voltage noise. Using a two-amplifier configuration (noninverting for high impedance plus inverting for negative feedback reasons) results in excessive phase lag and stability problems when the loop is closed. The VCA2612 uses a patented architecture that achieves these requirements, with the additional benefits of low power dissipation and differential signal handling at both input and output.

For greatest flexibility and lowest noise, the user may wish to shape the frequency response of the LNP. The COMP1 and COMP2 pins for each channel (pins 10 and 11 for channel A, pins 26 and 27 for channel B) correspond to the drains of  $Q_3$  and  $Q_8$  in Figure 4. A capacitor placed between these pins will create a single-pole low-pass response, in which the effective  $R$  of the  $RC$  time constant is approximately  $186\Omega$ .

### COMPENSATION WHEN USING ACTIVE FEEDBACK

The typical open-loop gain versus frequency characteristic for the LNP is shown in Figure 9. The  $-3\text{dB}$  bandwidth is approximately  $180\text{MHz}$  and the phase response is such that when feedback is applied the LNP will exhibit a peaked response or might even oscillate. One method for compensating for this undesirable behavior is to place a compensation capacitor at the input to the LNP, as shown in Figure 10. This method is effective when the desired  $-3\text{dB}$  bandwidth is much less than the open-loop bandwidth of the LNP. This compensation technique also allows the total compensation capacitor to include any stray or cable capacitance that is

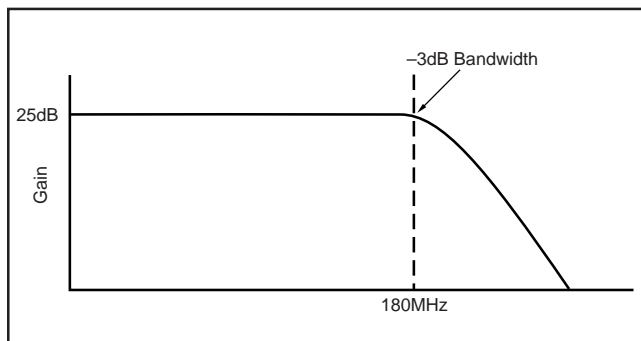

FIGURE 9. Open-Loop Gain Characteristic of LNP.

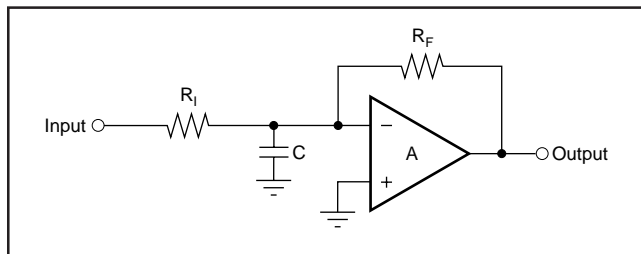

FIGURE 10. LNP with Compensation Capacitor.

associated with the input connection. Equation 4 relates the bandwidth to the various impedances that are connected to the LNP.

$$BW = \frac{(A + 1)R_1 + R_F}{2pC(R_1)(R_F)} \quad (4)$$

### LNP OUTPUT BUFFER

The differential LNP output is buffered by wideband class AB voltage followers which are designed to drive low impedance loads. This is necessary to maintain LNP gain accuracy, since the VCA input exhibits gain-dependent input impedance. The buffers are also useful when the LNP output is brought out to drive external filters or other signal processing circuitry. Good distortion performance is maintained with buffer loads as low as  $135\Omega$ . As mentioned previously, the buffer inputs are AC-coupled to the LNP outputs with a  $3.6\text{kHz}$  high-pass characteristic, and the DC common-mode level is maintained at the correct  $V_{CM}$  for compatibility with the VCA input.

### VOLTAGE-CONTROLLED ATTENUATOR (VCA)—DETAIL

The VCA is designed to have a  $\text{dB-linear}$  attenuation characteristic, i.e. the gain loss in  $\text{dB}$  is constant for each equal increment of the  $V_{CA\_CNTL}$  control voltage. See Figure 11 for a diagram of the VCA. The attenuator is essentially a variable voltage divider consisting of one series input resistor,  $R_S$ , and ten identical shunt FETs, placed in parallel and controlled by sequentially activated clipping amplifiers. Each clipping amplifier can be thought of as a specialized voltage comparator with a *soft* transfer characteristic and well-controlled output limit voltages. The reference voltages  $V_1$  through  $V_{10}$  are equally spaced over the  $0\text{V}$  to  $3.0\text{V}$  control voltage range. As the control voltage rises through the input range of each clipping amplifier, the amplifier output will rise from  $0\text{V}$  (FET completely *ON*) to  $V_{CM} - V_T$  (FET nearly *OFF*), where  $V_{CM}$  is the common source voltage and  $V_T$  is the threshold voltage of the FET. As each FET approaches its *OFF* state and the control voltage continues to rise, the next clipping amplifier/FET combination takes over for the next portion of the piecewise-linear attenuation characteristic. Thus, low control voltages have most of the FETs turned *ON*, while high control voltages have most turned *OFF*. Each FET acts to decrease the shunt resistance of the voltage divider formed by  $R_S$  and the parallel FET network.

The attenuator is comprised of two sections, with five parallel clipping amplifier/FET combinations in each. Special reference circuitry is provided so that the  $(V_{CM} - V_T)$  limit voltage will track temperature and IC process variations, minimizing the effects on the attenuator control characteristic.

In addition to the analog  $V_{CA\_CNTL}$  gain setting input, the attenuator architecture provides digitally programmable adjustment in eight steps, via the three Maximum Gain Setting (MGS) bits. These adjust the maximum achievable gain

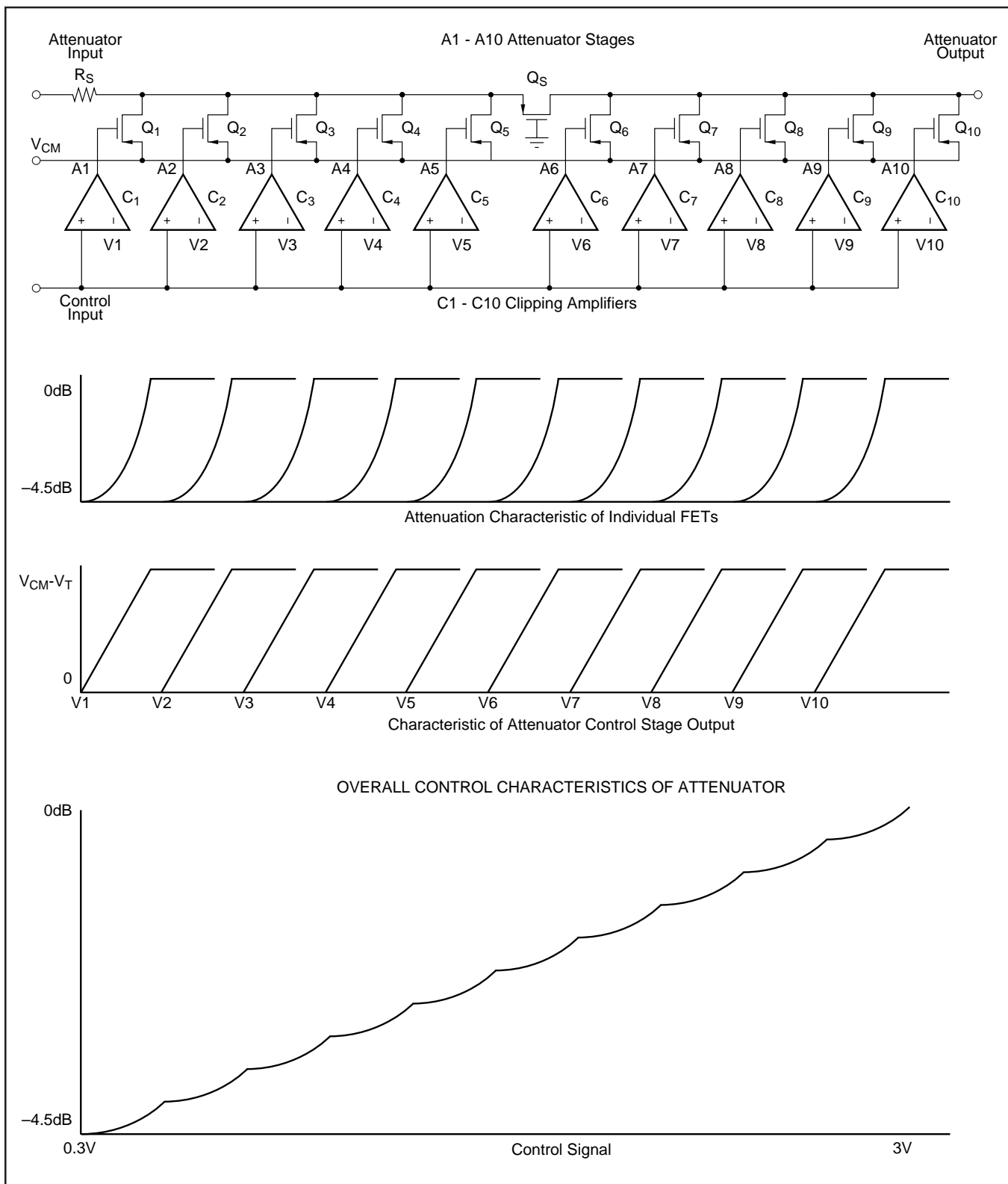

FIGURE 11. Piecewise Approximation to Logarithmic Control Characteristics.

(corresponding to minimum attenuation in the VCA, with  $VCA_{CNTL} = 3.0V$ ) in 3dB increments. This function is accomplished by providing multiple FET sub-elements for each of the  $Q_1$  to  $Q_{10}$  FET shunt elements shown in Figure 11. In the simplified diagram of Figure 12, each shunt FET is shown as two sub-elements,  $Q_{NA}$  and  $Q_{NB}$ . Selector

switches, driven by the MGS bits, activate either or both of the sub-element FETs to adjust the maximum  $R_{ON}$  and thus achieve the stepped attenuation options.

The VCA can be used to process either differential or single-ended signals. Fully differential operation will reduce 2nd-harmonic distortion by about 10dB for full-scale signals.

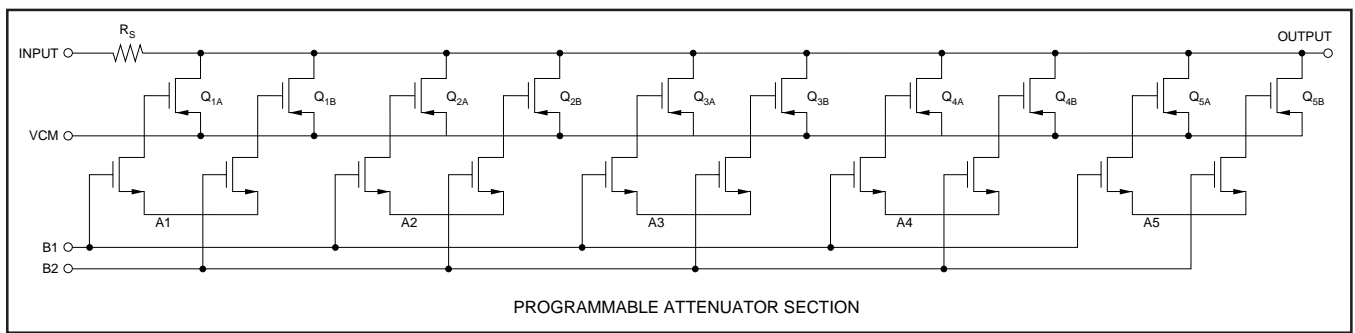

FIGURE 12. Programmable Attenuator Section.

Input impedance of the VCA will vary with gain setting, due to the changing resistances of the programmable voltage divider structure. At large attenuation factors (i.e., low gain settings), the impedance will approach the series resistor value of approximately 135Ω.

As with the LNP stage, the VCA output is AC-coupled into the PGA. This means that the attenuation-dependent DC common-mode voltage will not propagate into the PGA, and so the PGA's DC output level will remain constant.

Finally, note that the  $VCA_{CNTL}$  input consists of FET gate inputs. This provides very high impedance and ensures that multiple VCA2612 devices may be connected in parallel with no significant loading effects. The nominal voltage range for the  $VCA_{CNTL}$  input spans from 0V to 3V. Over driving this input ( $\leq 5V$ ) does not affect the performance.

### OVERLOAD RECOVERY CIRCUITRY—DETAIL

With a maximum overall gain of 70dB, the VCA2612 is prone to signal overloading. Such a condition may occur in either the LNP or the PGA depending on the various gain and attenuation settings available. The LNP is designed to produce low-distortion outputs as large as  $1V_{PP}$  single-ended ( $2V_{PP}$  differential). Therefore the maximum input signal for linear operation is  $2V_{PP}$  divided by the LNP differential gain setting. Clamping circuits in the LNP ensure that larger input amplitudes will exhibit symmetrical clipping and short recovery times. The VCA itself, being basically a voltage divider, is intrinsically free of overload conditions. However, the PGA post-amplifier is vulnerable to sudden overload, particularly at high gain settings. Rapid overload recovery is essential in many signal processing applications such as ultrasound imaging. A special comparator circuit is provided at the PGA input which detects overrange signals (detection level dependent on PGA gain setting). When the signal exceeds the comparator input threshold, the VCA output is blocked and an appropriate fixed DC level is substituted, providing fast and clean overload recovery. The basic architecture is shown in Figure 13. Both high and low overrange conditions are sensed and corrected by this circuit.

Figures 14 and 15 show typical overload recovery waveforms with  $MGS = 100$ , for VCA + PGA minimum gain (0dB) and maximum gain (36dB), respectively. LNP gain is set to 25dB in both cases.

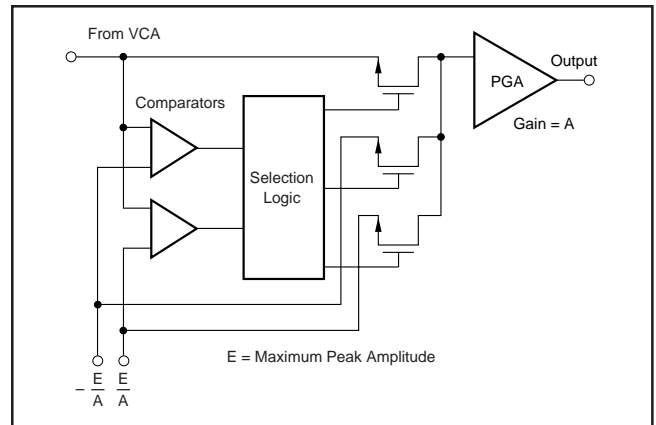

FIGURE 13. Overload Protection Circuitry.

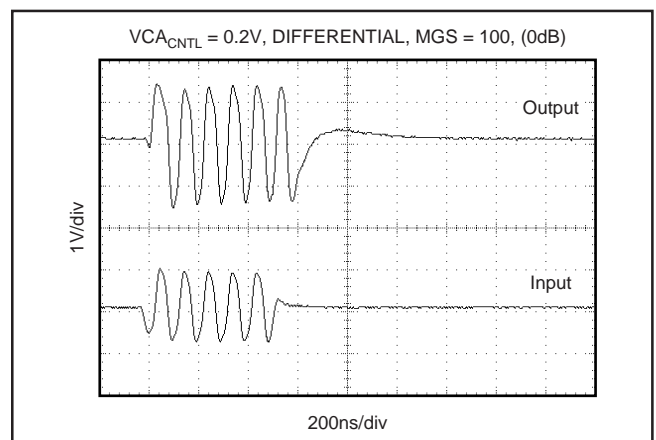

FIGURE 14. Overload Recovery Response For Minimum Gain.

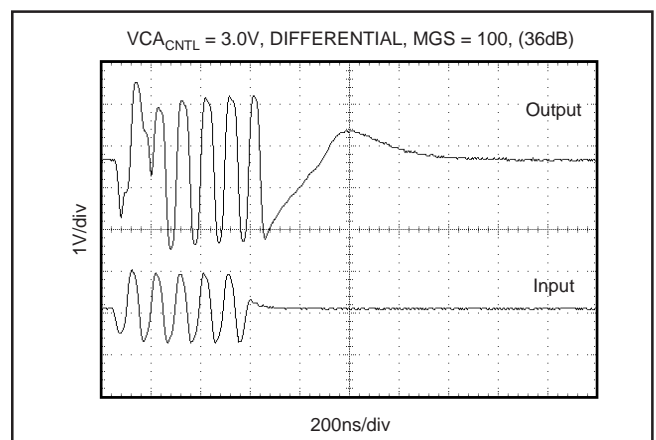

FIGURE 15. Overload Recovery Response For Maximum Gain.

## INPUT OVERLOAD RECOVERY

One of the most important applications for the VCA2612 is processing signals in an ultrasound system. The ultrasound signal flow begins when a large signal is applied to a transducer, which converts electrical energy to acoustic energy. It is not uncommon for the amplitude of the electrical signal that is applied to the transducer to be  $\pm 50V$  or greater. To prevent damage, it is necessary to place a protection circuit between the transducer and the VCA2612, as shown in Figure 16. Care must be taken to prevent any signal from turning the ESD diodes on. Turning on the ESD diodes inside the VCA2612 could cause the input coupling capacitor ( $C_C$ ) to charge to the wrong value.

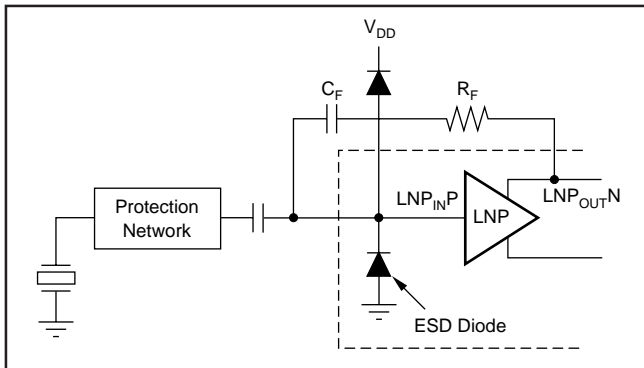

FIGURE 16. VCA2612 Diode Bridge Protection Circuit.

## PGA POST-AMPLIFIER—DETAIL

Figure 17 shows a simplified circuit diagram of the PGA block. As described previously, the PGA gain is programmed with the same MGS bits which control the VCA maximum attenuation factor. Specifically, the PGA gain at each MGS setting is the inverse (reciprocal) of the maximum VCA attenuation at

that setting. Therefore, the VCA + PGA overall gain will always be 0dB (unity) when the analog  $VCA_{CNTL}$  input is set to 0V (= maximum attenuation). For  $VCA_{CNTL} = 3V$  (no attenuation), the VCA + PGA gain will be controlled by the programmed PGA gain (24dB to 45dB in 3dB steps).

For clarity, the gain and attenuation factors are detailed in Table III.

| MGS SETTING | ATTENUATOR GAIN<br>$VCA_{CNTL} = 0V$ to $3V$ | DIFFERENTIAL<br>PGA GAIN | ATTENUATOR +<br>DIFF. PGA GAIN |
|-------------|--|--------------------------|--------------------------------|
| 000         | -24dB to 0dB                                 | 24dB                     | 0dB to 24dB                    |
| 001         | -27dB to 0dB                                 | 27dB                     | 0dB to 27dB                    |
| 010         | -30dB to 0dB                                 | 30dB                     | 0dB to 30dB                    |
| 011         | -33dB to 0dB                                 | 33dB                     | 0dB to 33dB                    |
| 100         | -36dB to 0dB                                 | 36dB                     | 0dB to 36dB                    |
| 101         | -39dB to 0dB                                 | 39dB                     | 0dB to 39dB                    |
| 110         | -42dB to 0dB                                 | 42dB                     | 0dB to 42dB                    |
| 111         | -45dB to 0dB                                 | 45dB                     | 0dB to 45dB                    |

TABLE III. MGS Settings.

The PGA architecture consists of a differential, programmable-gain voltage to current converter stage followed by transimpedance amplifiers to create and buffer each side of the differential output. The circuitry associated with the voltage to current converter is similar to that previously described for the LNP, with the addition of eight selectable PGA gain-setting resistor combinations (controlled by the MGS bits) in place of the fixed resistor network used in the LNP. Low input noise is also a requirement of the PGA design due to the large amount of signal attenuation which can be inserted between the LNP and the PGA. At minimum VCA attenuation (used for small input signals) the LNP noise dominates; at maximum VCA attenuation (large input signals) the PGA noise dominates. Note that if the PGA output is used single-ended, the apparent gain will be 6dB lower.

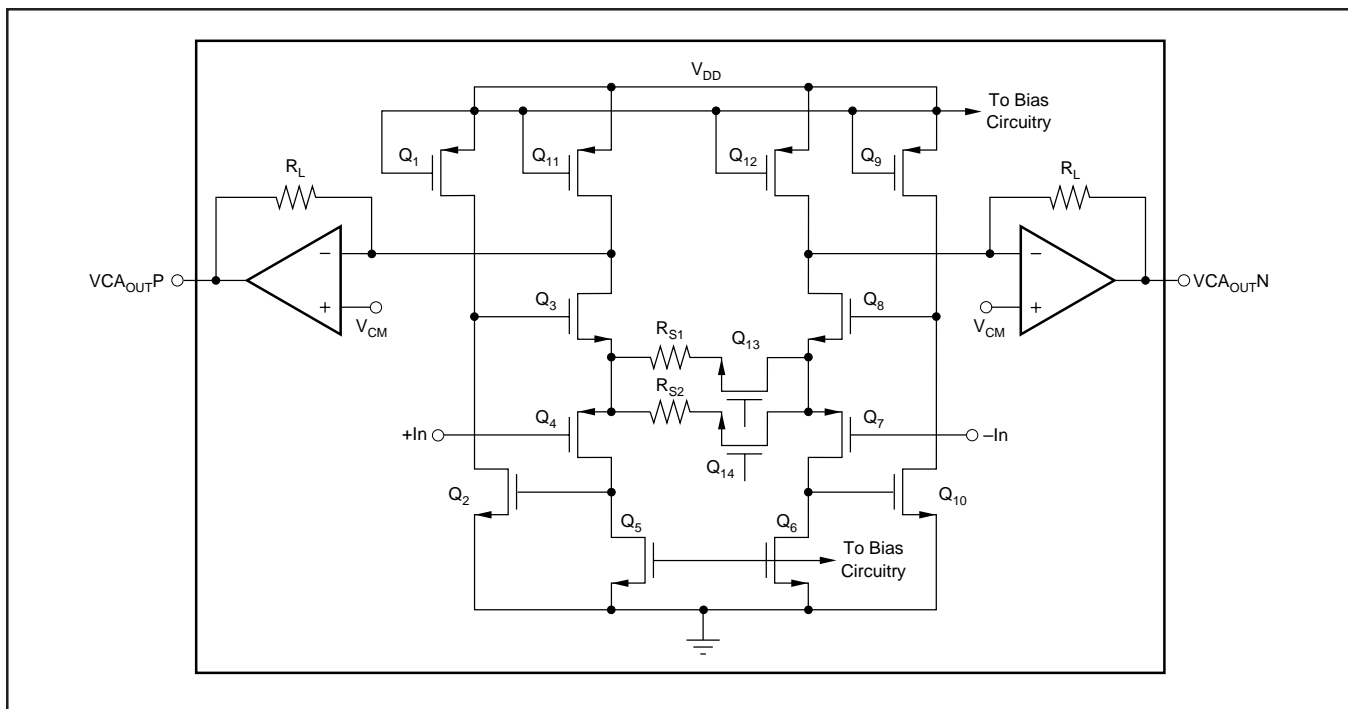

FIGURE 17. Simplified Block Diagram of the PGA Section Within the VCA2612.

**PACKAGING INFORMATION**

| Orderable Device | Status <sup>(1)</sup> | Package Type | Package Drawing | Pins | Package Qty | Eco Plan <sup>(2)</sup> | Lead/<br>Ball Finish | MSL Peak Temp <sup>(3)</sup> | Samples<br>(Requires Login) |
|------------------|-----------------------|--------------|-----------------|------|-------------|-------------------------|----------------------|------------------------------|-----------------------------|
| VCA2612Y/250     | ACTIVE                | TQFP         | PFB             | 48   | 250         | TBD                     | Call TI              | Call TI                      |                             |
| VCA2612Y/250G4   | ACTIVE                | TQFP         | PFB             | 48   | 250         | TBD                     | Call TI              | Call TI                      |                             |
| VCA2612Y/2K      | ACTIVE                | TQFP         | PFB             | 48   | 2000        | TBD                     | Call TI              | Call TI                      |                             |
| VCA2612Y/2KG4    | ACTIVE                | TQFP         | PFB             | 48   | 2000        | TBD                     | Call TI              | Call TI                      |                             |

<sup>(1)</sup> The marketing status values are defined as follows:

**ACTIVE:** Product device recommended for new designs.

**LIFEBUY:** TI has announced that the device will be discontinued, and a lifetime-buy period is in effect.

**NRND:** Not recommended for new designs. Device is in production to support existing customers, but TI does not recommend using this part in a new design.

**PREVIEW:** Device has been announced but is not in production. Samples may or may not be available.

**OBSOLETE:** TI has discontinued the production of the device.

<sup>(2)</sup> Eco Plan - The planned eco-friendly classification: Pb-Free (RoHS), Pb-Free (RoHS Exempt), or Green (RoHS & no Sb/Br) - please check <http://www.ti.com/productcontent> for the latest availability information and additional product content details.

**TBD:** The Pb-Free/Green conversion plan has not been defined.

**Pb-Free (RoHS):** TI's terms "Lead-Free" or "Pb-Free" mean semiconductor products that are compatible with the current RoHS requirements for all 6 substances, including the requirement that lead not exceed 0.1% by weight in homogeneous materials. Where designed to be soldered at high temperatures, TI Pb-Free products are suitable for use in specified lead-free processes.

**Pb-Free (RoHS Exempt):** This component has a RoHS exemption for either 1) lead-based flip-chip solder bumps used between the die and package, or 2) lead-based die adhesive used between the die and leadframe. The component is otherwise considered Pb-Free (RoHS compatible) as defined above.

**Green (RoHS & no Sb/Br):** TI defines "Green" to mean Pb-Free (RoHS compatible), and free of Bromine (Br) and Antimony (Sb) based flame retardants (Br or Sb do not exceed 0.1% by weight in homogeneous material)

<sup>(3)</sup> MSL, Peak Temp. -- The Moisture Sensitivity Level rating according to the JEDEC industry standard classifications, and peak solder temperature.

**Important Information and Disclaimer:** The information provided on this page represents TI's knowledge and belief as of the date that it is provided. TI bases its knowledge and belief on information provided by third parties, and makes no representation or warranty as to the accuracy of such information. Efforts are underway to better integrate information from third parties. TI has taken and continues to take reasonable steps to provide representative and accurate information but may not have conducted destructive testing or chemical analysis on incoming materials and chemicals. TI and TI suppliers consider certain information to be proprietary, and thus CAS numbers and other limited information may not be available for release.

In no event shall TI's liability arising out of such information exceed the total purchase price of the TI part(s) at issue in this document sold by TI to Customer on an annual basis.

PFB (S-PQFP-G48)

PLASTIC QUAD FLATPACK

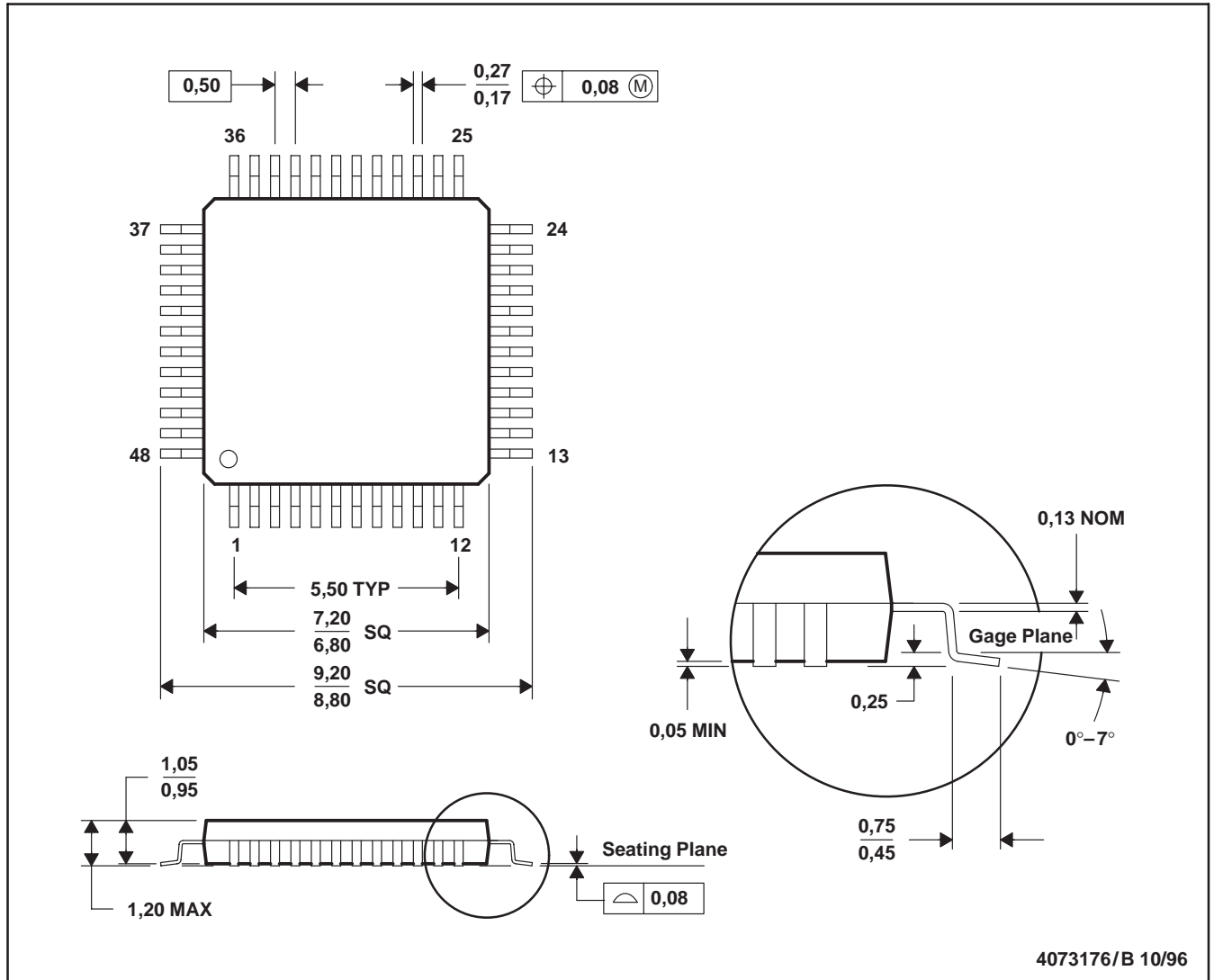

- NOTES: A. All linear dimensions are in millimeters.  
 B. This drawing is subject to change without notice.  
 C. Falls within JEDEC MS-026

PFB (S-PQFP-G48)

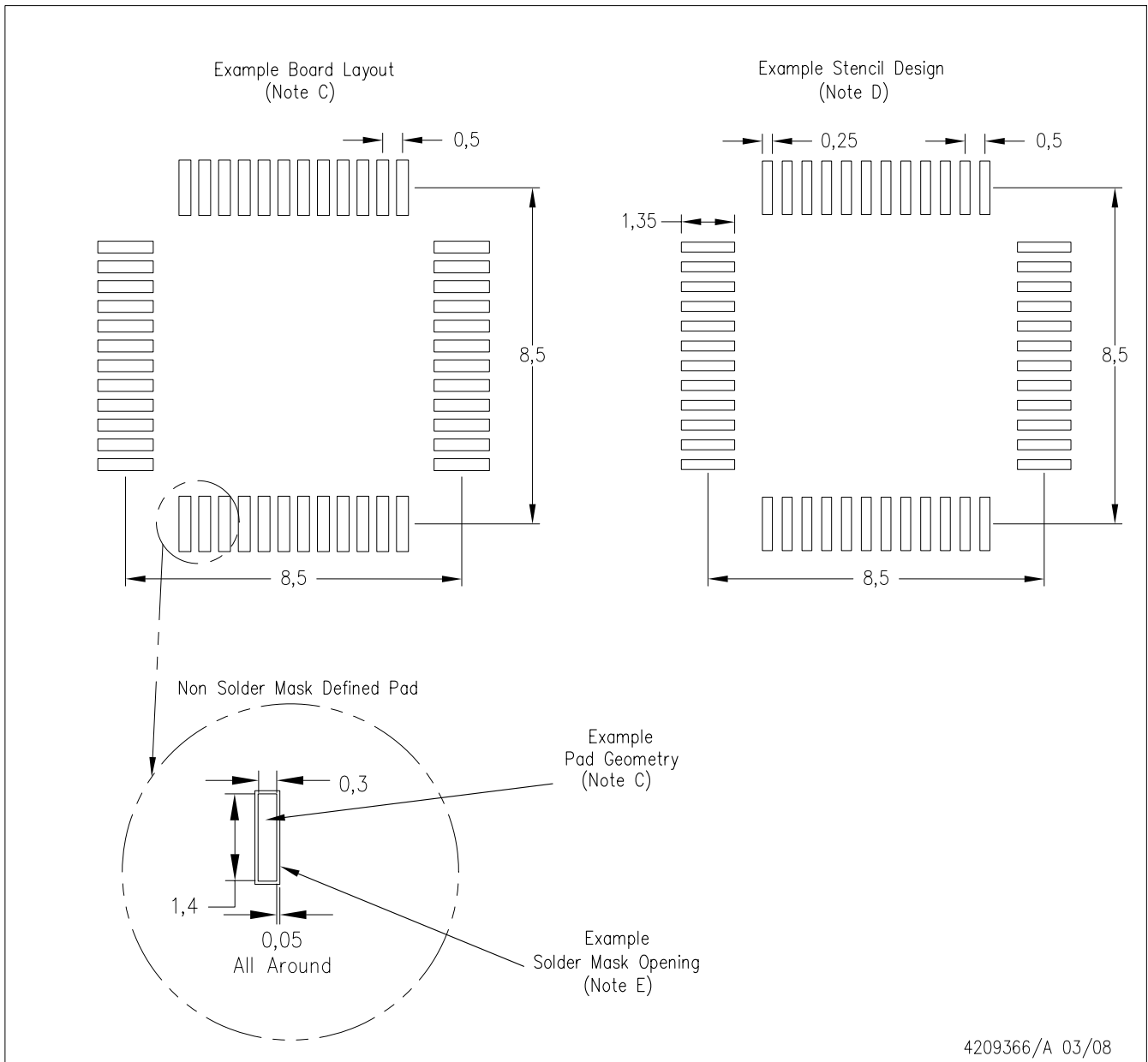

- NOTES:
- A. All linear dimensions are in millimeters.
  - B. This drawing is subject to change without notice.
  - C. Publication IPC-7351 is recommended for alternate designs.
  - D. Laser cutting apertures with trapezoidal walls and also rounding corners will offer better paste release. Customers should contact their board assembly site for stencil design recommendations. Refer to IPC-7525.
  - E. Customers should contact their board fabrication site for solder mask tolerances between and around signal pads.

## IMPORTANT NOTICE

Texas Instruments Incorporated and its subsidiaries (TI) reserve the right to make corrections, modifications, enhancements, improvements, and other changes to its products and services at any time and to discontinue any product or service without notice. Customers should obtain the latest relevant information before placing orders and should verify that such information is current and complete. All products are sold subject to TI's terms and conditions of sale supplied at the time of order acknowledgment.

TI warrants performance of its hardware products to the specifications applicable at the time of sale in accordance with TI's standard warranty. Testing and other quality control techniques are used to the extent TI deems necessary to support this warranty. Except where mandated by government requirements, testing of all parameters of each product is not necessarily performed.

TI assumes no liability for applications assistance or customer product design. Customers are responsible for their products and applications using TI components. To minimize the risks associated with customer products and applications, customers should provide adequate design and operating safeguards.

TI does not warrant or represent that any license, either express or implied, is granted under any TI patent right, copyright, mask work right, or other TI intellectual property right relating to any combination, machine, or process in which TI products or services are used. Information published by TI regarding third-party products or services does not constitute a license from TI to use such products or services or a warranty or endorsement thereof. Use of such information may require a license from a third party under the patents or other intellectual property of the third party, or a license from TI under the patents or other intellectual property of TI.

Reproduction of TI information in TI data books or data sheets is permissible only if reproduction is without alteration and is accompanied by all associated warranties, conditions, limitations, and notices. Reproduction of this information with alteration is an unfair and deceptive business practice. TI is not responsible or liable for such altered documentation. Information of third parties may be subject to additional restrictions.

Resale of TI products or services with statements different from or beyond the parameters stated by TI for that product or service voids all express and any implied warranties for the associated TI product or service and is an unfair and deceptive business practice. TI is not responsible or liable for any such statements.

TI products are not authorized for use in safety-critical applications (such as life support) where a failure of the TI product would reasonably be expected to cause severe personal injury or death, unless officers of the parties have executed an agreement specifically governing such use. Buyers represent that they have all necessary expertise in the safety and regulatory ramifications of their applications, and acknowledge and agree that they are solely responsible for all legal, regulatory and safety-related requirements concerning their products and any use of TI products in such safety-critical applications, notwithstanding any applications-related information or support that may be provided by TI. Further, Buyers must fully indemnify TI and its representatives against any damages arising out of the use of TI products in such safety-critical applications.

TI products are neither designed nor intended for use in military/aerospace applications or environments unless the TI products are specifically designated by TI as military-grade or "enhanced plastic." Only products designated by TI as military-grade meet military specifications. Buyers acknowledge and agree that any such use of TI products which TI has not designated as military-grade is solely at the Buyer's risk, and that they are solely responsible for compliance with all legal and regulatory requirements in connection with such use.

TI products are neither designed nor intended for use in automotive applications or environments unless the specific TI products are designated by TI as compliant with ISO/TS 16949 requirements. Buyers acknowledge and agree that, if they use any non-designated products in automotive applications, TI will not be responsible for any failure to meet such requirements.

Following are URLs where you can obtain information on other Texas Instruments products and application solutions:

### Products

|                             |  |
|-----------------------------|--|
| Audio                       | <a href="http://www.ti.com/audio">www.ti.com/audio</a>             |
| Amplifiers                  | <a href="http://amplifier.ti.com">amplifier.ti.com</a>             |
| Data Converters             | <a href="http://dataconverter.ti.com">dataconverter.ti.com</a>     |
| DLP® Products               | <a href="http://www.dlp.com">www.dlp.com</a>                       |
| DSP                         | <a href="http://dsp.ti.com">dsp.ti.com</a>                         |
| Clocks and Timers           | <a href="http://www.ti.com/clocks">www.ti.com/clocks</a>           |
| Interface                   | <a href="http://interface.ti.com">interface.ti.com</a>             |
| Logic                       | <a href="http://logic.ti.com">logic.ti.com</a>                     |
| Power Mgmt                  | <a href="http://power.ti.com">power.ti.com</a>                     |
| Microcontrollers            | <a href="http://microcontroller.ti.com">microcontroller.ti.com</a> |
| RFID                        | <a href="http://www.ti-rfid.com">www.ti-rfid.com</a>               |
| RF/IF and ZigBee® Solutions | <a href="http://www.ti.com/lprf">www.ti.com/lprf</a>               |

### Applications

|                               |  |
|-------------------------------|--|
| Communications and Telecom    | <a href="http://www.ti.com/communications">www.ti.com/communications</a>                 |
| Computers and Peripherals     | <a href="http://www.ti.com/computers">www.ti.com/computers</a>                           |
| Consumer Electronics          | <a href="http://www.ti.com/consumer-apps">www.ti.com/consumer-apps</a>                   |
| Energy and Lighting           | <a href="http://www.ti.com/energy">www.ti.com/energy</a>                                 |
| Industrial                    | <a href="http://www.ti.com/industrial">www.ti.com/industrial</a>                         |
| Medical                       | <a href="http://www.ti.com/medical">www.ti.com/medical</a>                               |
| Security                      | <a href="http://www.ti.com/security">www.ti.com/security</a>                             |
| Space, Avionics and Defense   | <a href="http://www.ti.com/space-avionics-defense">www.ti.com/space-avionics-defense</a> |
| Transportation and Automotive | <a href="http://www.ti.com/automotive">www.ti.com/automotive</a>                         |
| Video and Imaging             | <a href="http://www.ti.com/video">www.ti.com/video</a>                                   |
| Wireless                      | <a href="http://www.ti.com/wireless-apps">www.ti.com/wireless-apps</a>                   |

TI E2E Community Home Page

[e2e.ti.com](http://e2e.ti.com)

Mailing Address: Texas Instruments, Post Office Box 655303, Dallas, Texas 75265  
Copyright © 2011, Texas Instruments Incorporated