

VOLTAGE REFERENCE SCALING TECHNIQUES Increase the Accuracy of the Converter as well as Resolution

By Bonnie Baker

Temperature sensing can be one of the more challenging physical entities to measure if a variety of ranges and levels of accuracy are required by one electrical system. The circuit in Figure 1 uses a low power, single-supply analog-to-digital converter, ADS7816, configured with a thermocouple and CJC sub-circuit to achieve the desired range of responsiveness as well as high accuracy. The thermocouple is interfaced with a 12-bit A/D converter that allows for an adjustable input range. This range is adjusted with the voltage reference input. The range of the voltage reference input of the ADS7816 A/D converter is from the supply voltage (+5V typically) all the way down to 0.1V. The voltage reference range mimics a gain stage for the 12-bit converter. With this converter a auto-gain stage provides 17.6-bit virtual resolution against a 5V scale. When this circuit is properly calibrated for the desired temperature range, the effective resolution can be increased by 50x over a system with a standard 5V full-scale range.

Other converters in the same family include the ADS1286 and ADS7817 (see Table I). All three of these products have the unique characteristics of having a variable input range, while also being low power, low cost and available in 8-pin packages (such as PDIP, SOIC and MSOP). This product line, also known as the fly-spec converters, is only the

beginning of a new family of converters that take advantage of the versatile reference function and compact architecture. This application bulletin addresses the uniqueness of the voltage reference function to the A/D conversion process.

	ADS1286	ADS7816	ADS7817
Input Configuration	Single-Ended w/Sense Pin	Single-Ended w/Sense Pin	Full Differential
Maximum Sampling Rate	20kHz	200kHz	200kHz
Voltage Reference Range	100mV to Supply	100mV to Supply	50mV to Supply
Analog Input Voltage Range	V_{REF}	V_{REF}	$2V_{REF}$
Supply Voltage Range	4.5V - 5.25V	4.5V - 5.25V	4.75V - 5.25V
Minimum LSB Size to 12 Bits	24.4 μ V	24.4 μ V	24.4 μ V
Minimum Achievable LSB	51.79 μ V	51.79 μ V	51.79 μ V

TABLE I. Fyspec 12-Bit, Single Supply Converter Product Line Capable of Achieving Very Small Actual LSB Values.

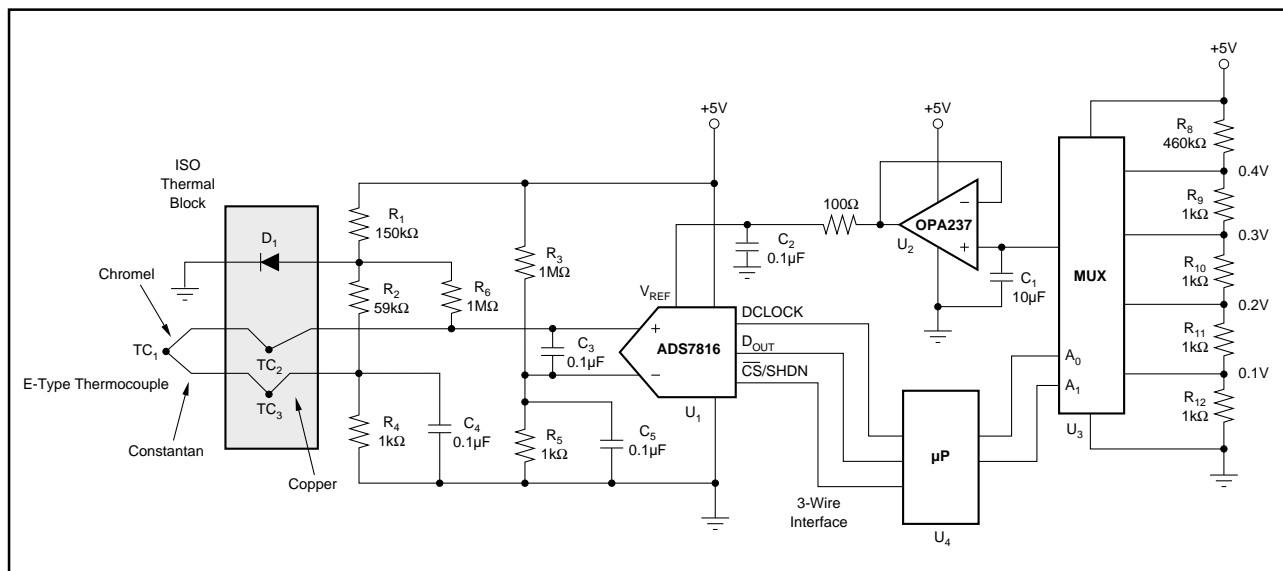

FIGURE 1. Thermocouple Application Using a MUX to Scale the Input Range of an Analog-to-Digital Converter in Order to Increase Accuracy as well as Resolution.

The key differentiating performance characteristics of these 12-bit A/D converters are summarized in Table I. In this product line, the A/D converter input configuration is either single-ended or differential. The single-ended style input stage has a additional “sense” (V_{IN-}) pin. The sense pin, in conjunction with the analog input pin, rejects small signals ($\pm 200\text{mV}$) common to both pins. This allows the user of the device to extend the signal lines coming to the device over a longer distance, giving the circuit a better chance to reject undesired radiated signals. The minimum LSB size is determined by the number of bits (in all these devices, 12 bits) and the minimum voltage that is assignable to the LSB, given the input voltage range. The minimum achievable LSB size is set by the actual accuracy of the converter with the given minimum input voltage range. The accuracy of the converter is defined by the measured rms (one sigma) noise levels at the output of the device after multiple conversions. This unique use of V_{REF} adjusts the full-scale range as well as the LSB size externally.

These converters can be used in a wide range of applications, one being thermocouple interface. A variety of thermocouples can be used for this application, such as “K”, “J” or “E” type devices. The thermocouple is constructed with two dissimilar metals that are connected together at one point. A voltage is created as a result of the temperature difference from one end of the metals to the other. The thermocouple used in this particular circuit is a type “E”. The materials used to build a type “E” thermocouple are Chromel and Constantan. The sensitivity of four different thermocouples is shown in the Table II below.

ISA TYPE	METALS USED FOR WIRES	TEMPERATURE COEFFICIENT ($\mu\text{V}/^\circ\text{C}$ at 0°C)	USEFUL TEMPERATURE RANGE ($^\circ\text{C}$)
E	Chromel/Constantan	58.5	0 to +1000
J	Iron/Constantan	50.2	0 to +1000
K	Chromel/Alumel	39.4	0 to +1300
T	Copper/Constantan	38.0	0 to +600

TABLE II. Temperature Coefficients of Various Thermocouple Types.

Thermocouples are low impedance, voltage output devices, requiring a temperature reference or compensation point. No voltage or current excitation is needed, which is a plus, however, their sensitivity is very low. For example, the K-Type thermocouple has approximately a $40\mu\text{V}/^\circ\text{C}$ sensitivity to changes in temperature and will change approximately 50mV for a temperature range of 0°C to 1300°C .

An application circuit that takes advantage of the unique voltage reference capability of the ADS7816 is shown in Figure 1. In this circuit, the two wires from the thermocouple are brought to an isothermal block. The isothermal block is

used as a temperature reference point to eliminate the voltage errors created by the two thermocouples built with the E-Type thermocouple leads are both connected to copper traces. At the isothermal block, a diode is used in conjunction with the resistors R_1 through R_6 to zero out the undesirable effects of the thermocouples that are built into the circuit as a result of connecting Chromel and Constantan wires to the PCB traces. The selection of the values of the resistors R_1 through R_5 depend on the type of thermocouple used, power requirements of the diode (D_1), A/D converter input offsets and overall power consumption requirements. In this circuit, the current to the CJC circuit is designed to a nominal $35\mu\text{A}$.

A designed-in offset ensures that offset variation from device to device of the A/D converter does not compromise the lower temperature readings. The difference at 0°C between the two inputs of the ADS7816 is designed to have a 5mV difference between the non-inverting and inverting inputs of the A/D converter. This 5mV difference accounts for temperatures below 0°C as well as a possible offset voltage with the A/D converter of 1mV (max). The ratio of the voltage divider of R_2 and R_4 is calculated to equal the drift of the “E” thermocouple ($58\mu\text{V}/^\circ\text{C}$) in relation to the diode drift ($-2.1\text{mV}/^\circ\text{C}$). The input range of the ADS7816 on the non-inverting input is equal to V_{IN+} minus V_{IN-} .

An open circuit indicator is implemented with the inclusion of R_6 . To insure that R_6 does not interface with the normal operation of the circuit, a high value is chosen, such as $1\text{M}\Omega$. In the event that the lines to the thermocouple are broken, the inverting input to the A/D converter immediately becomes the voltage at the diode, approximately 0.6V . This voltage easily exceeds any voltage that the thermocouple can generate as a result of high temperature exposure. The digital conversion of the diode voltage produces a full-scale output, which is flagged as an error condition by the $\mu\text{Processor}$ (U_4).

Typically, a thermocouple output voltage is gained by an analog front end, such as an instrumentation amplifier. The analog gain cell is set to insure that the signal full scale swing is equivalent to the A/D converter input range. The instrumentation amplifier can be eliminated by using the A/D converter with a smaller input range. This can be done by adjusting the reference voltage of the converter.

The ADS7816 is a 12-bit A/D converter with a sampling input. The input range of the ADS7816 A/D converter is equal to V_{IN+} minus V_{IN-} . The sense pin (V_{IN-}) input range is $\pm 200\text{mV}$. Reduced V_{REF} operates in the application as a gain increase by reducing the FSR of the converter. The A/D converter’s input range is decreased, while the converter continues to have 12-bit resolution. The multiplexer (U_3) uses the voltages generated by a voltage divider across the power supply. The range and absolute values of the voltages at the input of the multiplexer are dependent on the thermocouple type and temperature range of the application.

For a temperature range of 0°C to 1000°C, the delta voltage change of the “E” type thermocouple is 58mV. The output voltage of the multiplexer is filtered and buffered by a single supply op amp, U₂. The affect of changing the reference voltage is summarized in Table III and Table IV.

Although a thermocouple was used to illustrate the function of this circuit, other sensing devices can also be used making the multiplexer more useful. With this simple circuit the digital control can vary the gain coefficient from 1 to 50X.

V _{REF} INPUT	LSB VOLTAGE OF ADS7816	VIRTUAL ACCURACY TO 5V FSR	EFFECTIVE GAIN
5.00V	1220μV	12 Bits	1.00
3.75V	916μV	12.5 Bits	1.33
2.50V	610μV	13 Bits	2.00
1.25V	305μV	14 bits	4.00
0.50V	122μV	15.3 Bits	10.00
0.30V	73.2μV	16 Bits	16.67
0.20V	48.8μV	16.7 Bits	25.00
0.10V	24.5μV	17.6 Bits	50.00

TABLE III. By Decreasing V_{REF}, the Input Range of the ADS7816 Decreases One for One. The effective resolution remains at 12 bits, however, compared to a 5V FSR system the virtual accuracy is improved. The ‘Virtual Resolution’ shown in this table does not account for noise in the system, which could reduce the accuracy of the device (particularly at lower values of V_{REF}).

V _{REF} INPUT	DIFFERENTIAL INPUT VOLTAGE RANGE	LSB VOLTAGE OF ADS7817	VIRTUAL ACCURACY TO 5V FSR	EFFECTIVE GAIN
2.50V	±2.50V	1220μV	12 Bits	1.00
1.25V	±1.25V	612μV	13 Bits	2.00
0.50V	±0.50V	244μV	14.3 Bits	5.00
0.30V	±0.30V	146μV	15 Bits	8.33
0.20V	±0.20V	97.6μV	15.7 Bits	12.50
0.10V	±0.10V	49.0μV	16.3 Bits	25.00
0.05V	±0.05V	24.5μV	17.6 Bits	50.00

TABLE IV. The Input Range of the ADS7817 is Equal to Twice of the Reference Voltage. By decreasing V_{REF}, the input range of the ADS7817 decreases proportionally. The effective resolution remains at 12 bits. Compared to a 5V FSR system the virtual accuracy is improved. The ‘Virtual Resolution’ shown in this table does not account for noise in the system, which could reduce the accuracy of the device (particularly at lower values of V_{REF}).

The information provided herein is believed to be reliable; however, BURR-BROWN assumes no responsibility for inaccuracies or omissions. BURR-BROWN assumes no responsibility for the use of this information, and all use of such information shall be entirely at the user’s own risk. Prices and specifications are subject to change without notice. No patent rights or licenses to any of the circuits described herein are implied or granted to any third party. BURR-BROWN does not authorize or warrant any BURR-BROWN product for use in life support devices and/or systems.

IMPORTANT NOTICE

Texas Instruments and its subsidiaries (TI) reserve the right to make changes to their products or to discontinue any product or service without notice, and advise customers to obtain the latest version of relevant information to verify, before placing orders, that information being relied on is current and complete. All products are sold subject to the terms and conditions of sale supplied at the time of order acknowledgment, including those pertaining to warranty, patent infringement, and limitation of liability.

TI warrants performance of its semiconductor products to the specifications applicable at the time of sale in accordance with TI's standard warranty. Testing and other quality control techniques are utilized to the extent TI deems necessary to support this warranty. Specific testing of all parameters of each device is not necessarily performed, except those mandated by government requirements.

Customers are responsible for their applications using TI components.

In order to minimize risks associated with the customer's applications, adequate design and operating safeguards must be provided by the customer to minimize inherent or procedural hazards.

TI assumes no liability for applications assistance or customer product design. TI does not warrant or represent that any license, either express or implied, is granted under any patent right, copyright, mask work right, or other intellectual property right of TI covering or relating to any combination, machine, or process in which such semiconductor products or services might be or are used. TI's publication of information regarding any third party's products or services does not constitute TI's approval, warranty or endorsement thereof.