

Distributed by:

JAMECO[®]
ELECTRONICS

www.Jameco.com ♦ 1-800-831-4242

The content and copyrights of the attached
material are the property of its owner.

Jameco Part Number 901280



High-Side Measurement CURRENT SHUNT MONITOR

FEATURES

- COMPLETE UNIPOLAR HIGH-SIDE CURRENT MEASUREMENT CIRCUIT
- WIDE SUPPLY AND COMMON-MODE RANGE
- INA139: 2.7V to 40V
- INA169: 2.7V to 60V
- INDEPENDENT SUPPLY AND INPUT COMMON-MODE VOLTAGES
- SINGLE RESISTOR GAIN SET
- LOW QUIESCENT CURRENT (60µA typ)
- SOT23-5 PACKAGE

APPLICATIONS

- CURRENT SHUNT MEASUREMENT: Automotive, Telephone, Computers
- PORTABLE AND BATTERY-BACKUP SYSTEMS
- BATTERY CHARGERS
- POWER MANAGEMENT
- CELL PHONES
- PRECISION CURRENT SOURCE

DESCRIPTION

The INA139 and INA169 are high-side, unipolar, current shunt monitors. Wide input common-mode voltage range, high-speed, low quiescent current, and tiny SOT23 packaging enable use in a variety of applications.

Input common-mode and power-supply voltages are independent and can range from 2.7V to 40V for the INA139 and 2.7V to 60V for the INA169. Quiescent current is only 60µA, which permits connecting the power supply to either side of the current measurement shunt with minimal error.

The device converts a differential input voltage to a current output. This current is converted back to a voltage with an external load resistor that sets any gain from 1 to over 100. Although designed for current shunt measurement, the circuit invites creative applications in measurement and level shifting.

Both the INA139 and INA169 are available in SOT23-5 packages and are specified for the -40°C to +85°C industrial temperature range.

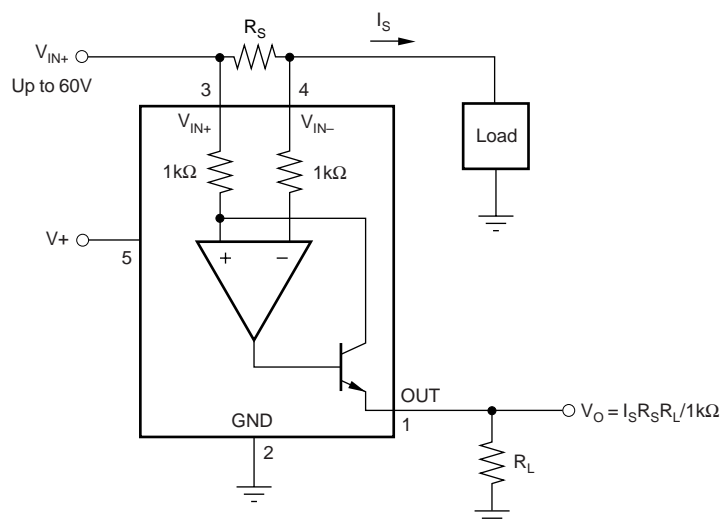

Please be aware that an important notice concerning availability, standard warranty, and use in critical applications of Texas Instruments semiconductor products and disclaimers thereto appears at the end of this data sheet.

All trademarks are the property of their respective owners.

PRODUCTION DATA information is current as of publication date. Products conform to specifications per the terms of Texas Instruments standard warranty. Production processing does not necessarily include testing of all parameters.

PACKAGE/ORDERING INFORMATION⁽¹⁾

PRODUCT	PACKAGE-LEAD	PACKAGE DESIGNATOR	SPECIFIED TEMPERATURE RANGE	PACKAGE MARKING	ORDERING NUMBER	TRANSPORT MEDIA, QUANTITY
INA139	SOT23-5 Surface-Mount	DBV	-40°C to +85°C	E39	INA139NA/250	Tape and Reel, 250
"	"	"	"	"	INA139NA/3K	Tape and Reel, 3000
INA169	SOT23-5 Surface-Mount	DBV	-40°C to +85°C	A69	INA169NA/250	Tape and Reel, 250
"	"	"	"	"	INA169NA/3K	Tape and Reel, 3000

NOTE: (1) For the most current package and ordering information, see the Package Option Addendum at the end of this document, or see the TI website at www.ti.com.

ABSOLUTE MAXIMUM RATINGS⁽¹⁾

Supply Voltage, V+	
INA139	-0.3V to 60V
INA169	-0.3V to 75V
Analog Inputs, V _{IN+} , V _{IN-}	
INA139	
Common Mode ⁽²⁾	-0.3V to 60V
Differential (V _{IN+}) - (V _{IN-})	-40V to 2V
INA169	
Common Mode ⁽²⁾	-0.3V to 75V
Differential (V _{IN+}) - (V _{IN-})	-40V to 2V
Analog Output, Out ⁽²⁾	-0.3V to 40V
Input Current Into Any Pin	10mA
Operating Temperature	-55°C to +125°C
Storage Temperature	-65°C to +125°C
Junction Temperature	+150°C

NOTE: (1) Stresses above these ratings may cause permanent damage. Exposure to absolute maximum conditions for extended periods may degrade device reliability. These are stress ratings only, and functional operation of the device at these or any other conditions beyond those specified is not implied. (2) The input voltage at any pin may exceed the voltage shown if the current at that pin is limited to 10mA.

PIN CONFIGURATION

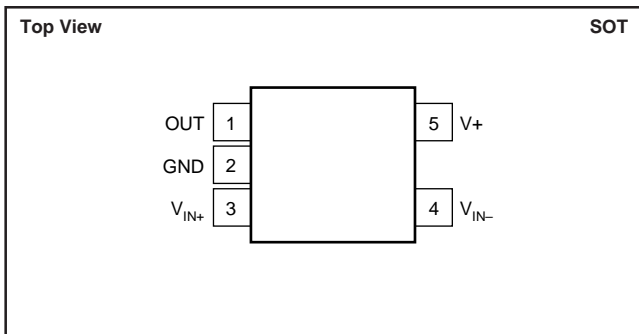

ELECTROSTATIC DISCHARGE SENSITIVITY

This integrated circuit can be damaged by ESD. Texas Instruments recommends that all integrated circuits be handled with appropriate precautions. Failure to observe proper handling and installation procedures can cause damage.

ESD damage can range from subtle performance degradation to complete device failure. Precision integrated circuits may be more susceptible to damage because very small parametric changes could cause the device not to meet its published specifications.

ELECTRICAL CHARACTERISTICS

At $T_A = -40^{\circ}\text{C}$ to $+85^{\circ}\text{C}$, $V_S = 5\text{V}$, $V_{IN+} = 12\text{V}$, and $R_{OUT} = 25\text{k}\Omega$, unless otherwise noted.

PARAMETER	CONDITION	INA139NA			INA169NA			UNITS
		MIN	TYP	MAX	MIN	TYP	MAX	
INPUT								
Full-Scale Sense Voltage	$V_{SENSE} = (V_{IN+}) - (V_{IN-})$	2.7	100	500	*	*	*	mV
Common-Mode Input Range	$V_{IN+} = 2.7\text{V}$ to 40V , $V_{SENSE} = 50\text{mV}$	100	115	40	*		60	V
Common-Mode Rejection	$V_{IN+} = 2.7\text{V}$ to 60V , $V_{SENSE} = 50\text{mV}$				100	120		dB
Offset Voltage ⁽¹⁾ RTI			± 0.2	± 1		*	*	mV
vs Temperature	T_{MIN} to T_{MAX}		1			*		$\mu\text{V}/^{\circ}\text{C}$
vs Power Supply, $V+$	$V- = 2.7\text{V}$ to 40V , $V_{SENSE} = 50\text{mV}$		0.5	10				$\mu\text{V}/\text{V}$
	$V- = 2.7\text{V}$ to 60V , $V_{SENSE} = 50\text{mV}$					0.1	10	$\mu\text{V}/\text{V}$
Input Bias Current			10			*		μA
OUTPUT								
Transconductance	$V_{SENSE} = 10\text{mV} - 150\text{mV}$	990	1000	1010	*	*	*	$\mu\text{A}/\text{V}$
vs Temperature	$V_{SENSE} = 100\text{mV}$		10			*		$\text{nA}/^{\circ}\text{C}$
Nonlinearity Error	$V_{SENSE} = 10\text{mV}$ to 150mV		± 0.01	± 0.1		*	*	%
Total Output Error	$V_{SENSE} = 100\text{mV}$		± 0.5	± 2		*	*	%
Output Impedance			1 5			*		$\text{G}\Omega$ pF
Voltage Output								
Swing to Power Supply, $V+$			$(V+) - 0.9$	$(V+) - 1.2$		*	*	V
Swing to Common Mode, V_{CM}			$V_{CM} - 0.6$	$V_{CM} - 1.0$		*	*	V
FREQUENCY RESPONSE								
Bandwidth	$R_{OUT} = 10\text{k}\Omega$		440			*		kHz
	$R_{OUT} = 20\text{k}\Omega$		220			*		kHz
Settling Time (0.1%)	5V Step, $R_{OUT} = 10\text{k}\Omega$		2.5			*		μs
	5V Step, $R_{OUT} = 20\text{k}\Omega$		5.0			*		μs
NOISE								
Output-Current Noise Density			20			*		$\text{pA}/\sqrt{\text{Hz}}$
Total Output-Current Noise	$\text{BW} = 100\text{kHz}$		7			*		nA RMS
POWER SUPPLY								
Operating Range, $V+$		2.7		40	*		60	V
Quiescent Current	$V_{SENSE} = 0$, $I_O = 0$		60	125		*	*	μA
TEMPERATURE RANGE								
Specification, T_{MIN} to T_{MAX}		-40		85	*		*	$^{\circ}\text{C}$
Operating		-55		125	*		*	$^{\circ}\text{C}$
Storage		-65		150	*		*	$^{\circ}\text{C}$
Thermal Resistance θ_{JA}			200			*		$^{\circ}\text{C}/\text{W}$

* Specification same as for the INA139NA.

NOTE: (1) Defined as the amount of input voltage, V_{SENSE} , to drive the output to zero.

TYPICAL CHARACTERISTICS

At $T_A = +25^\circ\text{C}$, $V_+ = 5\text{V}$, $V_{IN+} = 12\text{V}$, and $R_L = 25\text{k}\Omega$, unless otherwise noted.

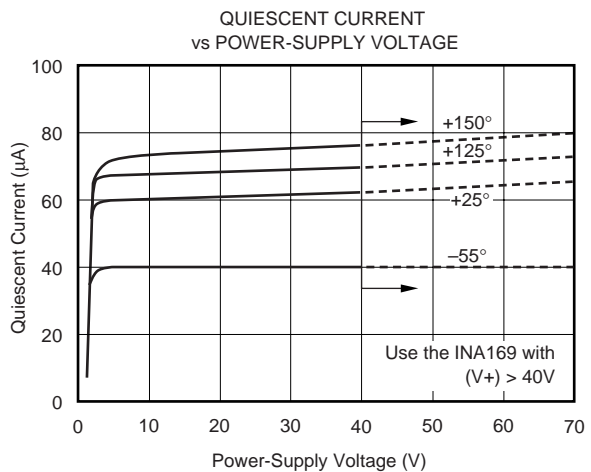
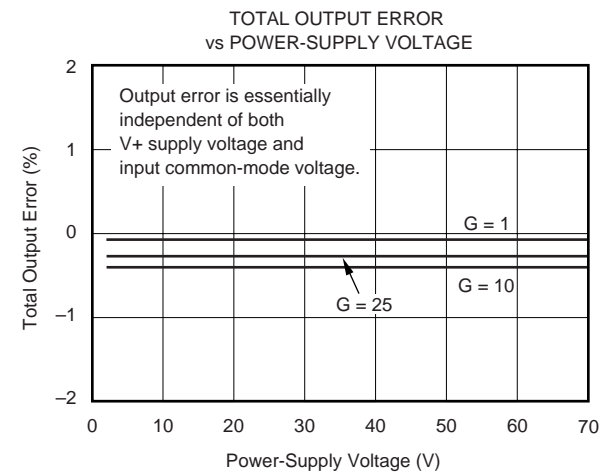
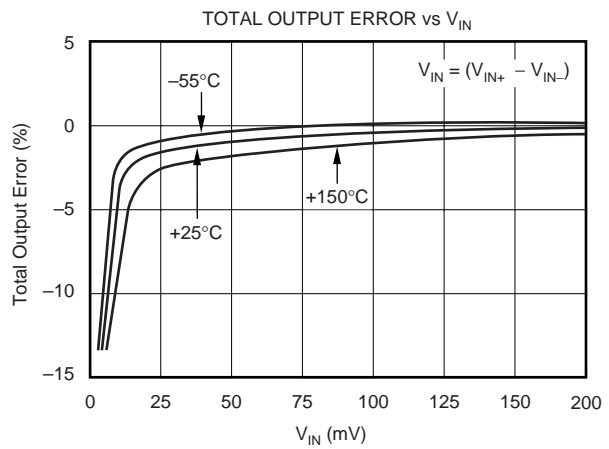
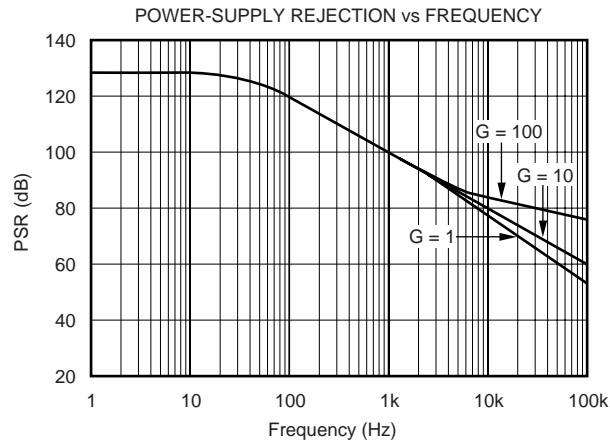
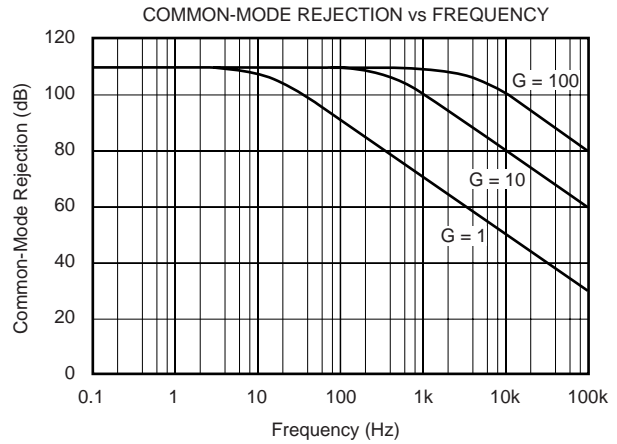
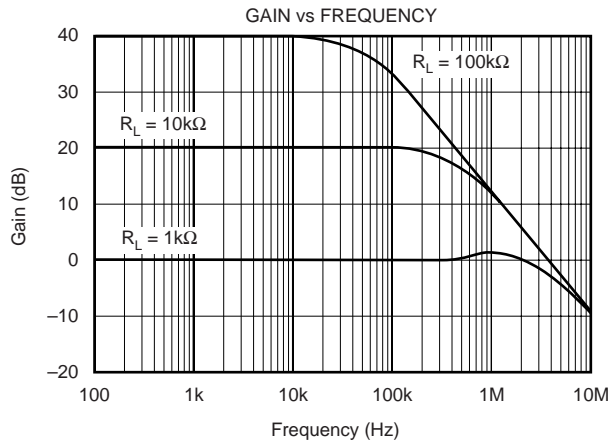

TYPICAL CHARACTERISTICS (Cont.)

At $T_A = +25^\circ\text{C}$, $V_+ = 5\text{V}$, $V_{IN+} = 12\text{V}$, and $R_L = 25\text{k}\Omega$, unless otherwise noted.

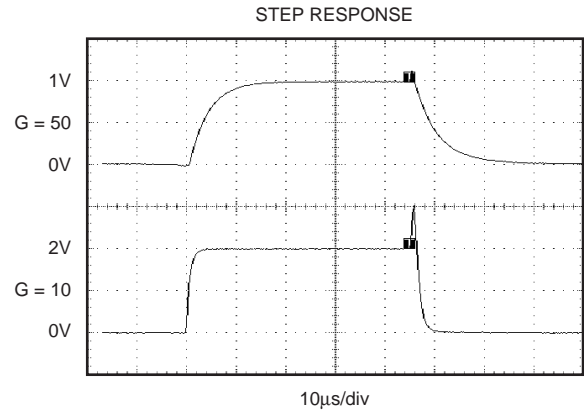
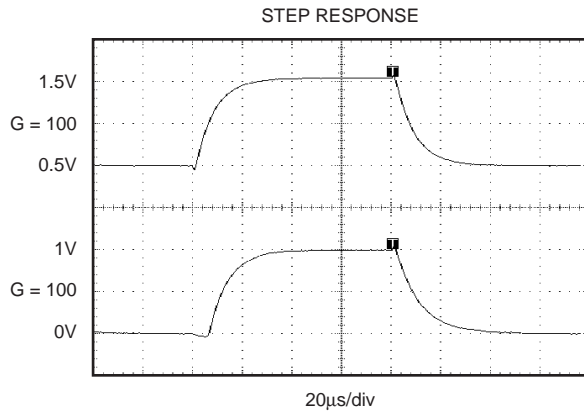

OPERATION

Figure 1 shows the basic circuit diagram for both the INA139 and the INA169. Load current, I_S , is drawn from the supply, V_S , through the shunt resistor, R_S . The voltage drop in the shunt resistor, V_S , is forced across R_{G1} by the internal op amp, causing current to flow into the collector of Q1. The external resistor, R_L , converts the output current to a voltage, V_{OUT} , at the OUT pin.

The transfer function for the INA139 is:

$$I_O = g_m (V_{IN+}) - (V_{IN-}) \quad (1)$$

$$\text{where } g_m = 1000\mu\text{A/V} \quad (2)$$

In the circuit of Figure 1, the input voltage, $(V_{IN+}) - (V_{IN-})$, is equal to $I_S \cdot R_S$ and the output voltage, V_{OUT} , is equal to $I_O \cdot R_L$. The transconductance, g_m , of the INA139 is $1000\mu\text{A/V}$. The complete transfer function for the current measurement amplifier in this application is:

$$V_{OUT} = (I_S) (R_S) (1000\mu\text{A/V}) (R_L) \quad (3)$$

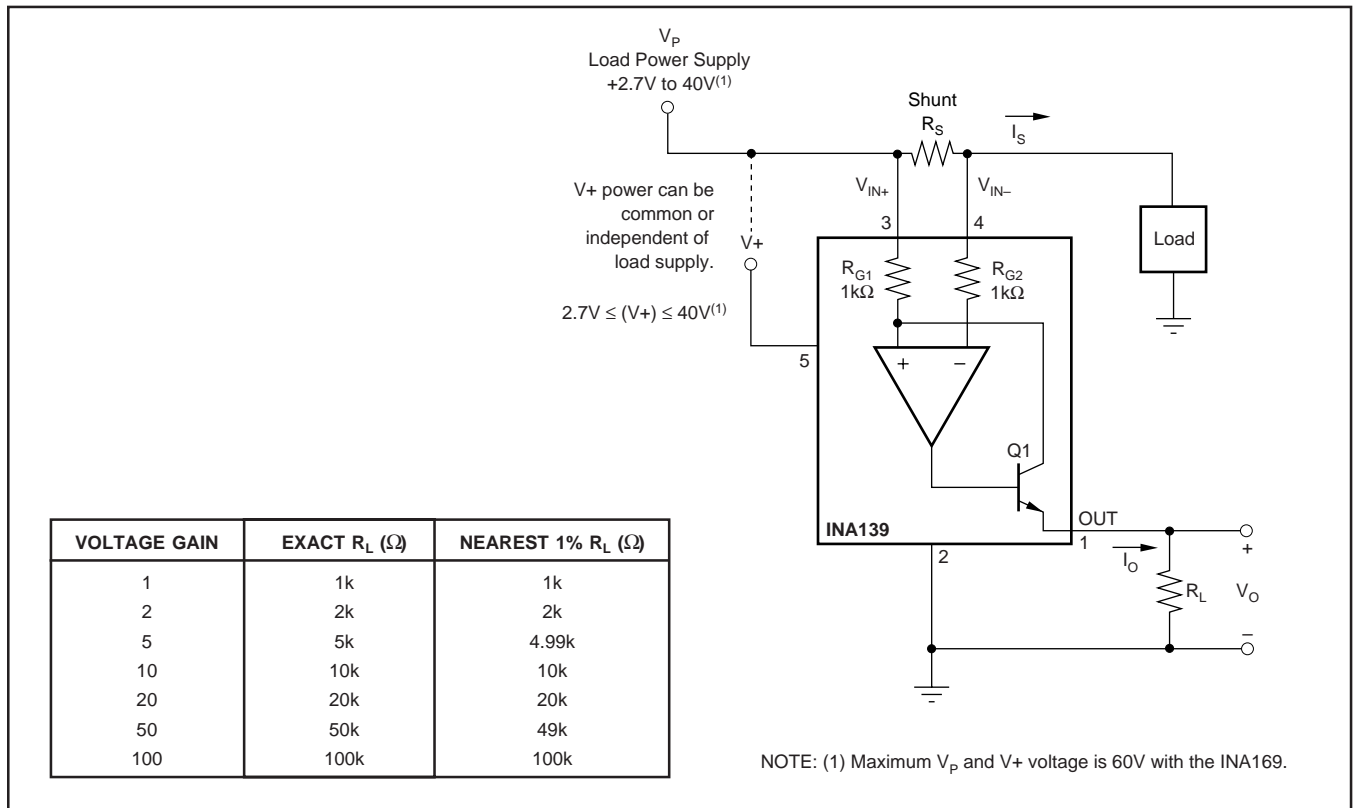

FIGURE 1. Basic Circuit Connections.

The maximum differential input voltage for accurate measurements is 0.5V, which produces a 500µA output current. A differential input voltage of up to 2V will not cause damage. Differential measurements (pins 3 and 4) must be unipolar with a more-positive voltage applied to pin 3. If a more-negative voltage is applied to pin 3, the output current (I_O) is zero, but will not cause damage.

BASIC CONNECTION

Figure 1 shows the basic connection of the INA139. The input pins, V_{IN+} and V_{IN-} , must be connected as closely as possible to the shunt resistor to minimize any resistance in series with the shunt resistance. The output resistor, R_L , is shown connected between pin 1 and ground. Best accuracy is achieved with the output voltage measured directly across R_L . This is especially important in high-current systems where load current can flow in the ground connections, affecting the measurement accuracy.

No power-supply bypass capacitors are required for stability of the INA139. However, applications with noisy or high-impedance power supplies can require decoupling capacitors to reject power-supply noise; connect the bypass capacitors close to the device pins.

POWER SUPPLIES

The input circuitry of the INA139 can accurately measure beyond its power-supply voltage, $V+$. For example, the $V+$ power supply can be 5V whereas the load power-supply voltage is up to +36V (or +60V with the INA169). However, the output voltage range of the OUT terminal (pin 1) is limited by the lesser of the two voltages (see the Output Voltage Range section).

SELECTING R_S AND R_L

The value chosen for the shunt resistor, R_S , depends on the application and is a compromise between small-signal accuracy and maximum permissible voltage loss in the measurement line. High values of R_S provide better accuracy at lower currents by minimizing the effects of offset, whereas low values of R_S minimize voltage loss in the supply line. For most applications, best performance is attained with an R_S value that provides a full-scale shunt voltage of 50mV to 100mV; maximum input voltage for accurate measurements is 500mV.

R_L is chosen to provide the desired full-scale output voltage. The output impedance of the INA139 OUT terminal is very high, which permits using values of R_L up to 100kΩ with excellent accuracy. The input impedance of any additional circuitry at the output must be much higher than the value of R_L to avoid degrading accuracy.

Some Analog-to-Digital (A/D) converters have input impedances that will significantly affect measurement gain. The input impedance of the A/D converter can be included as part of the effective R_L if its input can be modeled as a resistor to ground. Alternatively, an op amp can be used to buffer the A/D converter input, as shown in Figure 2, see Figure 1 for recommended values of R_L .

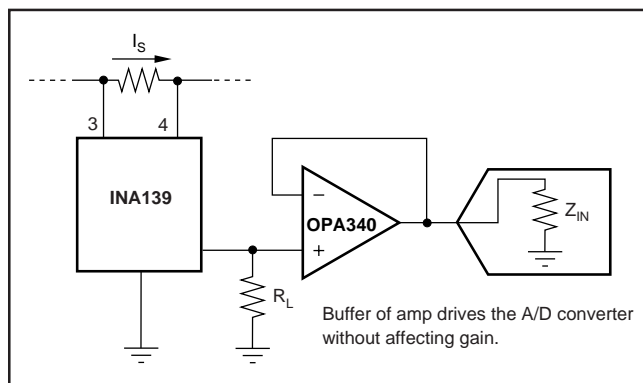

FIGURE 2. Buffering Output to Drive the A/D Converter.

OUTPUT VOLTAGE RANGE

The output of the INA139 is a current that is converted to a voltage by the load resistor, R_L . The output current remains accurate within the *compliance voltage range* of the output circuitry. The shunt voltage and the input common-mode and power-supply voltages limit the maximum possible output swing. The maximum output voltage compliance is limited by the lower of the two equations below:

$$V_{OUT\ MAX} = (V+) - 0.7V - (V_{IN+} - V_{IN-}) \quad (4)$$

or

$$V_{OUT\ MAX} = (V_{IN-}) - 0.5V \quad (5)$$

(whichever is lower)

BANDWIDTH

Measurement bandwidth is affected by the value of the load resistor, R_L . High gain produced by high values of R_L will yield a narrower measurement bandwidth (see the Typical Characteristics). For widest possible bandwidth, keep the capacitive load on the output to a minimum.

If bandwidth limiting (filtering) is desired, a capacitor can be added to the output, as shown in Figure 3, which will not cause instability.

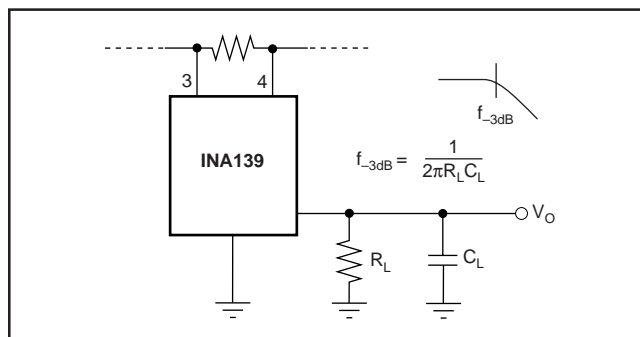

FIGURE 3. Output Filter.

APPLICATIONS

The INA139 is designed for current shunt measurement circuits (see Figure 1), but its basic function is useful in a wide range of circuitry. A creative engineer will find many unforeseen uses in measurement and level shifting circuits. A few ideas are illustrated in Figures 4 through 7.

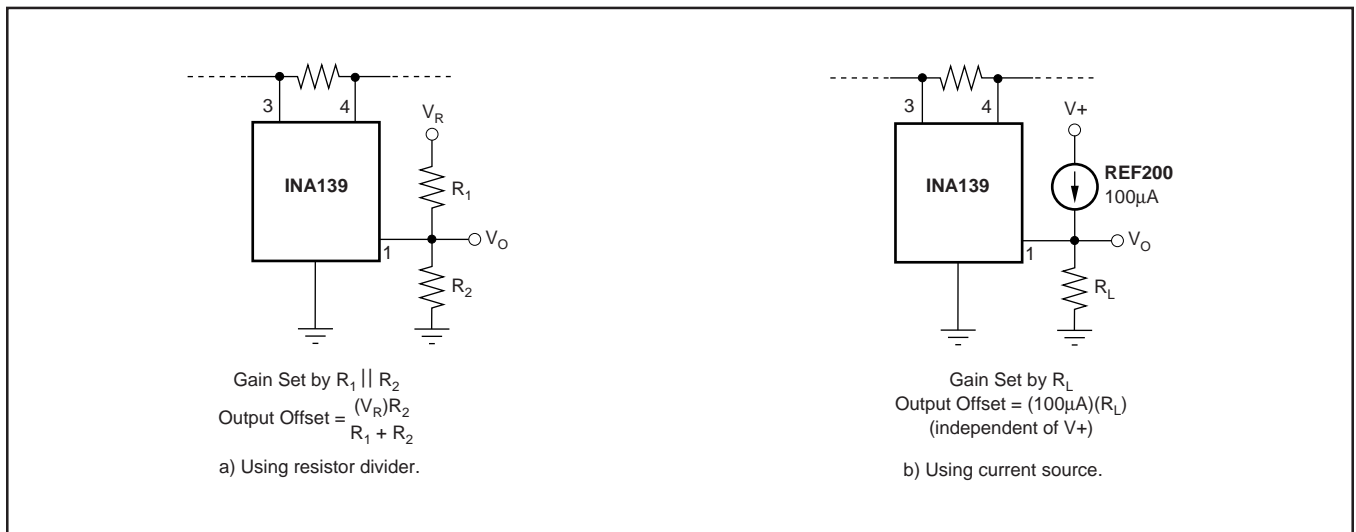

FIGURE 4. Offsetting the Output Voltage.

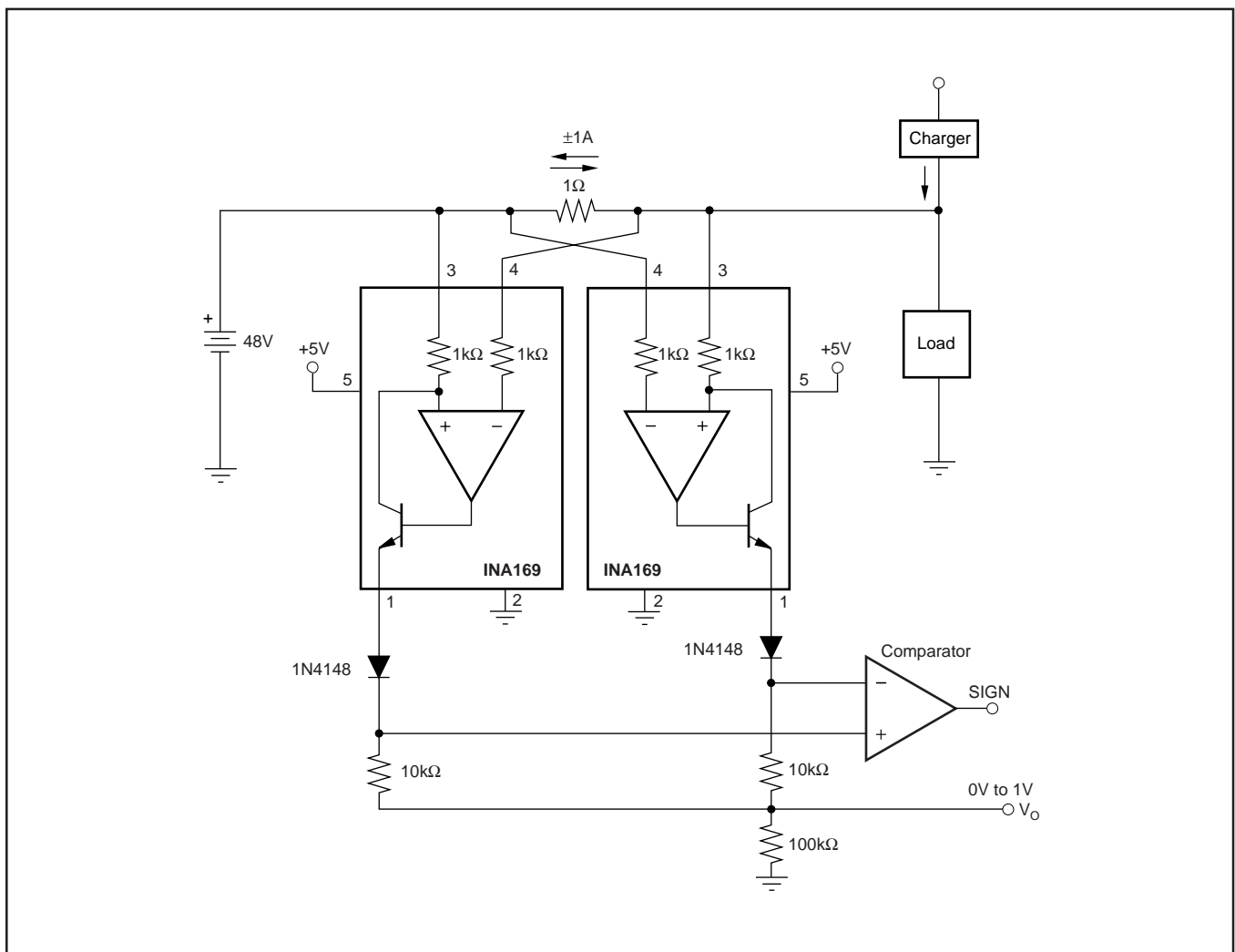

FIGURE 5. Bipolar Current Measurement.

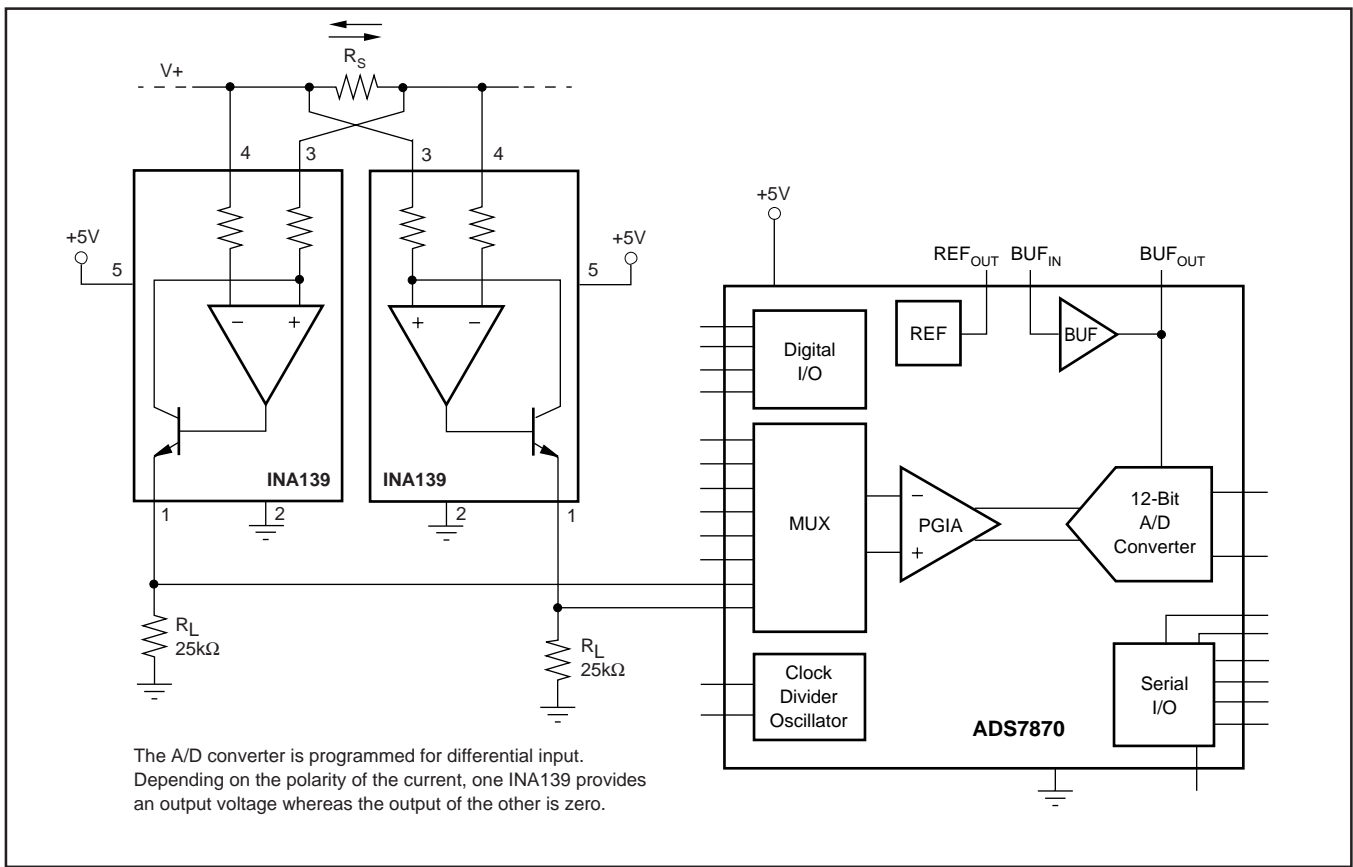

FIGURE 6. Bipolar Current Measurement Using a Differential Input of the A/D Converter.

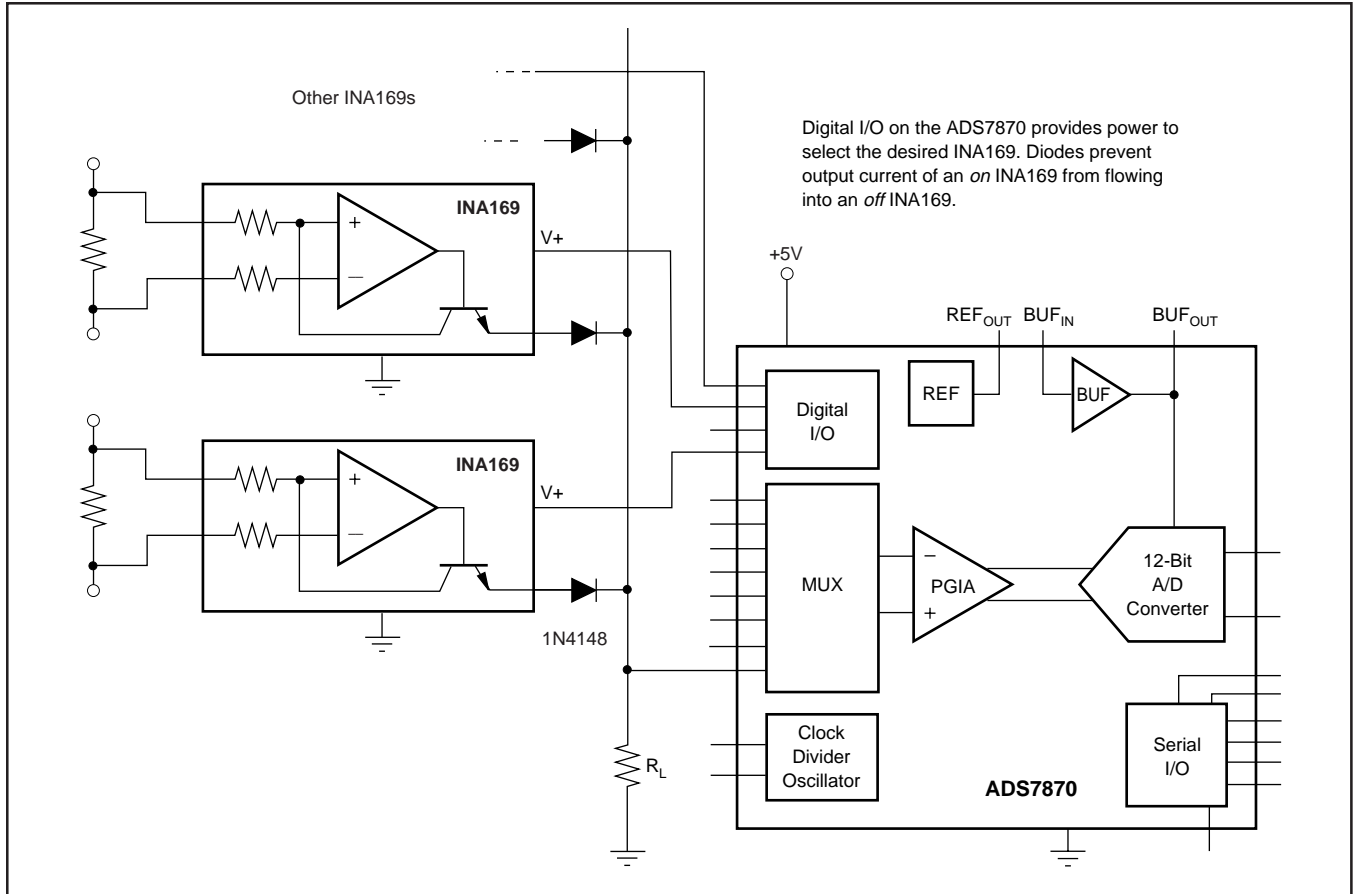

FIGURE 7. Multiplexed Measurement Using Logic Signal for Power.

PACKAGING INFORMATION

Orderable Device	Status ⁽¹⁾	Package Type	Package Drawing	Pins	Package Qty	Eco Plan ⁽²⁾	Lead/Ball Finish	MSL Peak Temp ⁽³⁾
INA139NA/250	ACTIVE	SOT-23	DBV	5	250	Green (RoHS & no Sb/Br)	CU NIPDAU	Level-2-260C-1 YEAR
INA139NA/250G4	ACTIVE	SOT-23	DBV	5	250	Green (RoHS & no Sb/Br)	CU NIPDAU	Level-2-260C-1 YEAR
INA139NA/3K	ACTIVE	SOT-23	DBV	5	3000	Green (RoHS & no Sb/Br)	CU NIPDAU	Level-2-260C-1 YEAR
INA139NA/3KG4	ACTIVE	SOT-23	DBV	5	3000	Green (RoHS & no Sb/Br)	CU NIPDAU	Level-2-260C-1 YEAR
INA169NA/250	ACTIVE	SOT-23	DBV	5	250	Green (RoHS & no Sb/Br)	CU NIPDAU	Level-2-260C-1 YEAR
INA169NA/250G4	ACTIVE	SOT-23	DBV	5	250	Green (RoHS & no Sb/Br)	CU NIPDAU	Level-2-260C-1 YEAR
INA169NA/3K	ACTIVE	SOT-23	DBV	5	3000	Green (RoHS & no Sb/Br)	CU NIPDAU	Level-2-260C-1 YEAR
INA169NA/3KG4	ACTIVE	SOT-23	DBV	5	3000	Green (RoHS & no Sb/Br)	CU NIPDAU	Level-2-260C-1 YEAR

⁽¹⁾ The marketing status values are defined as follows:

ACTIVE: Product device recommended for new designs.

LIFEBUY: TI has announced that the device will be discontinued, and a lifetime-buy period is in effect.

NRND: Not recommended for new designs. Device is in production to support existing customers, but TI does not recommend using this part in a new design.

PREVIEW: Device has been announced but is not in production. Samples may or may not be available.

OBSOLETE: TI has discontinued the production of the device.

⁽²⁾ Eco Plan - The planned eco-friendly classification: Pb-Free (RoHS), Pb-Free (RoHS Exempt), or Green (RoHS & no Sb/Br) - please check <http://www.ti.com/productcontent> for the latest availability information and additional product content details.

TBD: The Pb-Free/Green conversion plan has not been defined.

Pb-Free (RoHS): TI's terms "Lead-Free" or "Pb-Free" mean semiconductor products that are compatible with the current RoHS requirements for all 6 substances, including the requirement that lead not exceed 0.1% by weight in homogeneous materials. Where designed to be soldered at high temperatures, TI Pb-Free products are suitable for use in specified lead-free processes.

Pb-Free (RoHS Exempt): This component has a RoHS exemption for either 1) lead-based flip-chip solder bumps used between the die and package, or 2) lead-based die adhesive used between the die and leadframe. The component is otherwise considered Pb-Free (RoHS compatible) as defined above.

Green (RoHS & no Sb/Br): TI defines "Green" to mean Pb-Free (RoHS compatible), and free of Bromine (Br) and Antimony (Sb) based flame retardants (Br or Sb do not exceed 0.1% by weight in homogeneous material)

⁽³⁾ MSL, Peak Temp. -- The Moisture Sensitivity Level rating according to the JEDEC industry standard classifications, and peak solder temperature.

Important Information and Disclaimer:The information provided on this page represents TI's knowledge and belief as of the date that it is provided. TI bases its knowledge and belief on information provided by third parties, and makes no representation or warranty as to the accuracy of such information. Efforts are underway to better integrate information from third parties. TI has taken and continues to take reasonable steps to provide representative and accurate information but may not have conducted destructive testing or chemical analysis on incoming materials and chemicals. TI and TI suppliers consider certain information to be proprietary, and thus CAS numbers and other limited information may not be available for release.

In no event shall TI's liability arising out of such information exceed the total purchase price of the TI part(s) at issue in this document sold by TI to Customer on an annual basis.

DBV (R-PDSO-G5)

PLASTIC SMALL-OUTLINE PACKAGE

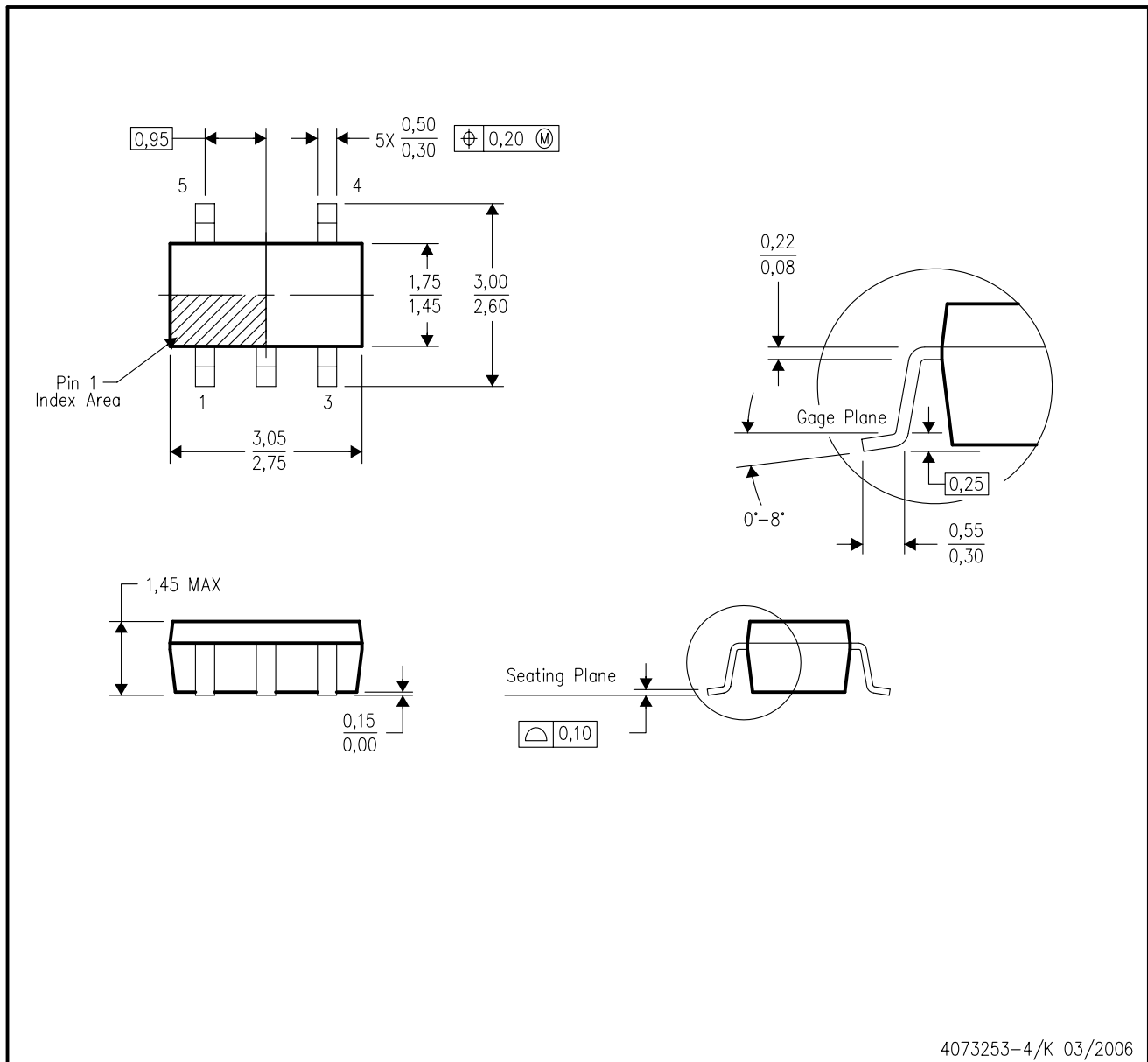

- NOTES:
- A. All linear dimensions are in millimeters.
 - B. This drawing is subject to change without notice.
 - C. Body dimensions do not include mold flash or protrusion. Mold flash and protrusion shall not exceed 0.15 per side.
 - D. Falls within JEDEC MO-178 Variation AA.

IMPORTANT NOTICE

Texas Instruments Incorporated and its subsidiaries (TI) reserve the right to make corrections, modifications, enhancements, improvements, and other changes to its products and services at any time and to discontinue any product or service without notice. Customers should obtain the latest relevant information before placing orders and should verify that such information is current and complete. All products are sold subject to TI's terms and conditions of sale supplied at the time of order acknowledgment.

TI warrants performance of its hardware products to the specifications applicable at the time of sale in accordance with TI's standard warranty. Testing and other quality control techniques are used to the extent TI deems necessary to support this warranty. Except where mandated by government requirements, testing of all parameters of each product is not necessarily performed.

TI assumes no liability for applications assistance or customer product design. Customers are responsible for their products and applications using TI components. To minimize the risks associated with customer products and applications, customers should provide adequate design and operating safeguards.

TI does not warrant or represent that any license, either express or implied, is granted under any TI patent right, copyright, mask work right, or other TI intellectual property right relating to any combination, machine, or process in which TI products or services are used. Information published by TI regarding third-party products or services does not constitute a license from TI to use such products or services or a warranty or endorsement thereof. Use of such information may require a license from a third party under the patents or other intellectual property of the third party, or a license from TI under the patents or other intellectual property of TI.

Reproduction of information in TI data books or data sheets is permissible only if reproduction is without alteration and is accompanied by all associated warranties, conditions, limitations, and notices. Reproduction of this information with alteration is an unfair and deceptive business practice. TI is not responsible or liable for such altered documentation.

Resale of TI products or services with statements different from or beyond the parameters stated by TI for that product or service voids all express and any implied warranties for the associated TI product or service and is an unfair and deceptive business practice. TI is not responsible or liable for any such statements.

Following are URLs where you can obtain information on other Texas Instruments products and application solutions:

Products		Applications	
Amplifiers	amplifier.ti.com	Audio	www.ti.com/audio
Data Converters	dataconverter.ti.com	Automotive	www.ti.com/automotive
DSP	dsp.ti.com	Broadband	www.ti.com/broadband
Interface	interface.ti.com	Digital Control	www.ti.com/digitalcontrol
Logic	logic.ti.com	Military	www.ti.com/military
Power Mgmt	power.ti.com	Optical Networking	www.ti.com/opticalnetwork
Microcontrollers	microcontroller.ti.com	Security	www.ti.com/security
Low Power Wireless	www.ti.com/lpw	Telephony	www.ti.com/telephony
		Video & Imaging	www.ti.com/video
		Wireless	www.ti.com/wireless

Mailing Address: Texas Instruments
Post Office Box 655303 Dallas, Texas 75265