



# DAC7613

For most current data sheet and other product information, visit [www.burr-brown.com](http://www.burr-brown.com)

## 12-Bit, Voltage Output DIGITAL-TO-ANALOG CONVERTER

### FEATURES

- **LOW POWER:** 1.8mW
- **UNIPOLAR OR BIPOLAR OPERATION**
- **SETTLING TIME:** 10 $\mu$ s to 0.012%
- **12-BIT LINEARITY AND MONOTONICITY:** -40°C to +85°C
- **DATA READBACK**
- **DOUBLE-BUFFERED DATA INPUTS**
- **24-LEAD SSOP PACKAGE**

### APPLICATIONS

- **PROCESS CONTROL**
- **CLOSED-LOOP SERVO-CONTROL**
- **MOTOR CONTROL**
- **DATA ACQUISITION SYSTEMS**

### DESCRIPTION

The DAC7613 is a 12-bit, voltage output digital-to-analog converter with guaranteed 12-bit monotonic performance over the specified temperature range. The DAC7613 accepts a 12-bit parallel input data, has double-buffered DAC input logic and provides a readback mode of the internal input register. An asynchronous reset clears all registers to a mid-scale code of 800<sub>H</sub> or to a zero-scale of 000<sub>H</sub>. The DAC7613 can operate from a single +5V supply or from +5V and -5V supplies.

Low power and small size makes the DAC7613 ideal for data acquisition systems and closed-loop servo-control. The DAC7613 is available in a plastic SSOP-24 package, and offers guaranteed specifications over the -40°C to +85°C temperature range.

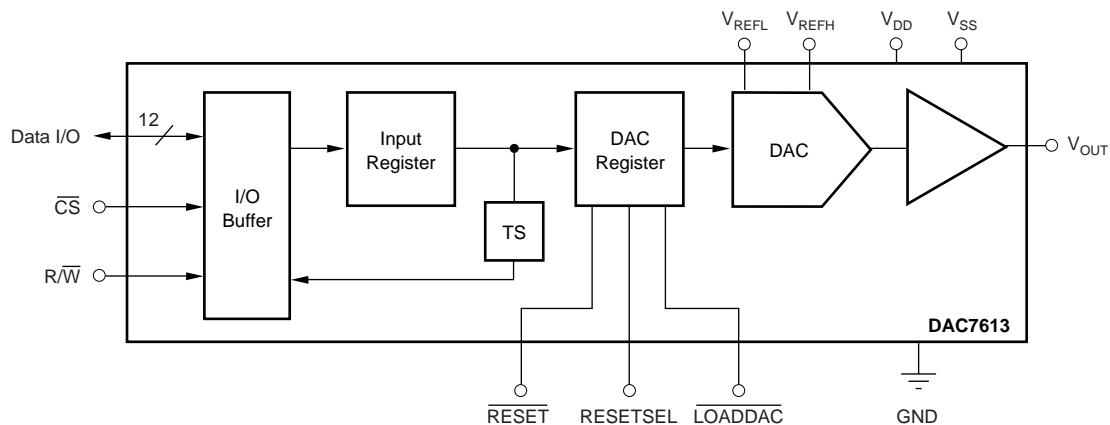

International Airport Industrial Park • Mailing Address: PO Box 11400, Tucson, AZ 85734 • Street Address: 6730 S. Tucson Blvd., Tucson, AZ 85706 • Tel: (520) 746-1111  
Twx: 910-952-1111 • Internet: <http://www.burr-brown.com/> • Cable: BBRCORP • Telex: 066-6491 • FAX: (520) 889-1510 • Immediate Product Info: (800) 548-6132

# SPECIFICATION

At  $T_A = -40^{\circ}\text{C}$  to  $+85^{\circ}\text{C}$ ,  $V_{DD} = +5\text{V}$ ,  $V_{SS} = -5\text{V}$ ,  $V_{REFH} = +2.5\text{V}$ , and  $V_{REFL} = -2.5\text{V}$ , unless otherwise noted.

PARAMETER	CONDITIONS	DAC7613E			DAC7613EB			UNITS
		MIN	TYP	MAX	MIN	TYP	MAX	
<b>ACCURACY</b>								
Linearity Error <sup>(1)</sup>	$V_{SS} = 0\text{V}$ or $-5\text{V}$			$\pm 2$			$\pm 1$	LSB <sup>(2)</sup>
Differential Linearity Error	$V_{SS} = 0\text{V}$ or $-5\text{V}$			$\pm 1$			$\pm 1$	LSB
Monotonicity	$T_{MIN}$ to $T_{MAX}$	12			*			Bits
Zero-Scale Error	Code = $000_H$			$\pm 4$			*	LSB
Zero-Scale Drift			2	5		*	*	ppm/ $^{\circ}\text{C}$
Full-Scale Error	Code = $FFF_H$			$\pm 4$			*	LS
Zero-Scale Error	Code = $00A_H$ , $V_{SS} = 0\text{V}$			$\pm 8$			*	LSB
Zero-Scale Drift	$V_{SS} = 0\text{V}$		5	10		*	*	ppm/ $^{\circ}\text{C}$
Full-Scale Error	Code = $FFF_H$ , $V_{SS} = 0\text{V}$			$\pm 8$			*	LSB
Power Supply Rejection			30			*		ppm/V
<b>ANALOG OUTPUT</b>								
Voltage Output <sup>(3)</sup>	$V_{REFL} = 0\text{V}$ , $V_{SS} = 0\text{V}$ $V_{SS} = -5\text{V}$	0 $V_{REFL}$ -1.25		$V_{REFH}$ $V_{REFH}$ +1.25	*		*	V V mA
Output Current							*	
Load Capacitance	No Oscillation		100			*		pF
Short-Circuit Current			+5, -15			*		mA
Short-Circuit Duration			Indefinite			*		
<b>REFERENCE INPUT</b>								
$V_{REFH}$ Input Range	$V_{SS} = 0\text{V}$ or $-5\text{V}$	$V_{REFL} + 1.25$		+2.5	*		*	V
$V_{REFL}$ Input Range	$V_{SS} = 0\text{V}$	0		$V_{REFH} - 1.25$	*		*	V
$V_{REFL}$ Input Range	$V_{SS} = -5\text{V}$	-2.5		$V_{REFH} - 1.25$	*		*	V
<b>DYNAMIC PERFORMANCE</b>								
Settling Time <sup>(4)</sup>	To $\pm 0.012\%$		5	10		*	*	$\mu\text{s}$
Output Noise Voltage	0Hz to 1MHz		40			*		nV/ $\sqrt{\text{Hz}}$
<b>DIGITAL INPUT/OUTPUT</b>								
Logic Family			CMOS		*			
Logic Levels								
$V_{IH}$	$I_{IH} \leq \pm 10\mu\text{A}$	$0.7 V_{DD}$		$V_{DD} + 0.3$	*		*	V
$V_{IL}$	$I_{IL} \leq \pm 10\mu\text{A}$	-0.3		$0.3 V_{DD}$	*		*	V
$V_{OH}$	$I_{OH} = -0.8\text{mA}$	3.6		$V_{DD}$	*		*	V
$V_{OL}$	$I_{OL} = 1.6\text{mA}$	0.0		0.4	*		*	V
Data Format			Straight Binary			*		
<b>POWER SUPPLY REQUIREMENTS</b>								
$V_{DD}$		4.75		5.25	*		*	V
$V_{SS}$	If $V_{SS} \neq 0\text{V}$	-5.25		-4.75	*		*	V
$I_{DD}$			0.35	0.5		*	*	mA
$I_{SS}$		-0.65	-0.45		*	*	*	mA
Power Dissipation	$V_{SS} = -5\text{V}$		4	5.75		*	*	mW
	$V_{SS} = 0\text{V}$		1.8	2.5		*	*	mW
<b>TEMPERATURE RANGE</b>								
Specified Performance		-40		+85	*		*	$^{\circ}\text{C}$

NOTES: (1) If  $V_{SS} = 0\text{V}$ , specification applies at code  $00A_H$  and above. (2) LSB means Least Significant Bit, when  $V_{REFH}$  equals +2.5V and  $V_{REFL}$  equals -2.5V, then one LSB equals 1.22mV. (3) Ideal output voltage, does not take into account zero or full-scale error. (4) If  $V_{SS} = -5\text{V}$ , full-scale 5V step. If  $V_{SS} = 0\text{V}$ , full-scale positive 2.5V step and negative step from code  $FFF_H$  to  $00A_H$ .

The information provided herein is believed to be reliable; however, BURR-BROWN assumes no responsibility for inaccuracies or omissions. BURR-BROWN assumes no responsibility for the use of this information, and all use of such information shall be entirely at the user's own risk. Prices and specifications are subject to change without notice. No patent rights or licenses to any of the circuits described herein are implied or granted to any third party. BURR-BROWN does not authorize or warrant any BURR-BROWN product for use in life support devices and/or systems.

## ABSOLUTE MAXIMUM RATINGS<sup>(1)</sup>

$V_{DD}$ to $V_{SS}$ .....	-0.3V to 11V
$V_{DD}$ to GND .....	-0.3V to 5.5V
$V_{REFL}$ to $V_{SS}$ .....	-0.3V to ( $V_{DD} - V_{SS}$ )
$V_{DD}$ to $V_{REFH}$ .....	-0.3V to ( $V_{DD} - V_{SS}$ )
$V_{REFH}$ to $V_{REFL}$ .....	-0.3V to ( $V_{DD} - V_{SS}$ )
Digital Input Voltage to GND .....	-0.3V to $V_{DD} + 0.3V$
Digital Output Voltage to GND .....	-0.3V to $V_{DD} + 0.3V$
Maximum Junction Temperature .....	+150°C
Operating Temperature Range .....	-40°C to +85°C
Storage Temperature Range .....	-65°C to +150°C
Lead Temperature (soldering, 10s) .....	+300°C

NOTE: (1) Stresses above those listed under "Absolute Maximum Ratings" may cause permanent damage to the device. Exposure to absolute maximum conditions for extended periods may affect device reliability.



## ELECTROSTATIC DISCHARGE SENSITIVITY

This integrated circuit can be damaged by ESD. Burr-Brown recommends that all integrated circuits be handled with appropriate precautions. Failure to observe proper handling and installation procedures can cause damage.

ESD damage can range from subtle performance degradation to complete device failure. Precision integrated circuits may be more susceptible to damage because very small parametric changes could cause the device not to meet its published specifications.

## PACKAGE/ORDERING INFORMATION

PRODUCT	MAXIMUM LINEARITY ERROR (LSB)	MAXIMUM DIFFERENTIAL LINEARITY ERROR (LSB)	PACKAGE	PACKAGE DRAWING NUMBER	SPECIFICATION TEMPERATURE RANGE	ORDERING NUMBER <sup>(1)</sup>	TRANSPORT MEDIA
DAC7613E	±2	±1	SSOP-24	338	-40°C to +85°C	DAC7613E	Rails
"	"	"	"	"	"	DAC7613E/1K	Tape and Reel
DAC7613EB	±1	±1	SSOP-24	338	-40°C to +85°C	DAC7613EB	Rails
"	"	"	"	"	"	DAC7613EB/1K	Tape and Reel

NOTE: (1) Models with a slash (/) are available only in Tape and Reel in the quantities indicated (e.g., /1K indicates 1000 devices per reel). Ordering 1000 pieces of "DAC7613E/1K" will get a single 1000-piece Tape and Reel.

## PIN CONFIGURATION

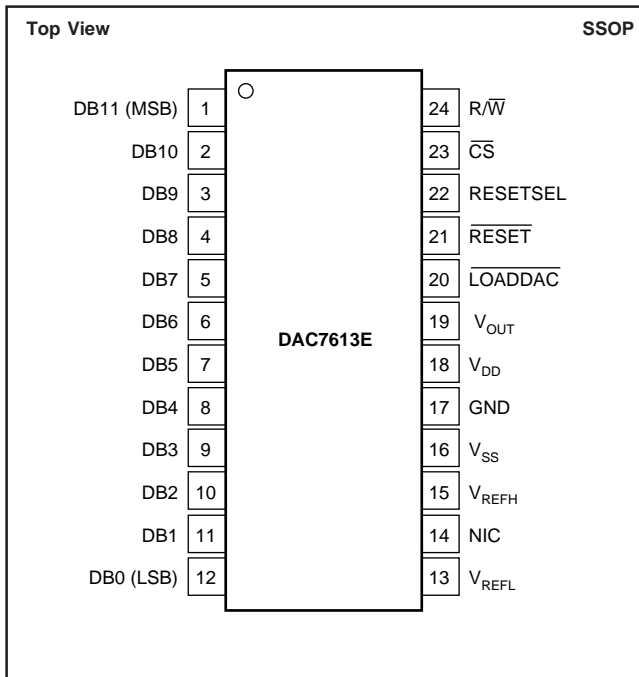

## PIN DESCRIPTIONS

PIN	LABEL	DESCRIPTION
1	DB11	Data Bit 11, MSB
2	DB10	Data Bit 10
3	DB9	Data Bit 9
4	DB8	Data Bit 8
5	DB7	Data Bit 7
6	DB6	Data Bit 6
7	DB5	Data Bit 5
8	DB4	Data Bit 4
9	DB3	Data Bit 3
10	DB2	Data Bit 2
11	DB1	Data Bit 1
12	DB0	Data Bit 0, LSB
13	V <sub>REFL</sub>	Reference Input Voltage Low. Sets minimum output voltage for the DAC.
14	NIC	Not Internally Connected
15	V <sub>REFH</sub>	Reference Input Voltage High. Sets maximum output voltage for the DAC.
16	V <sub>SS</sub>	Negative Analog Supply Voltage, 0V or -5V nominal.
17	GND	Ground
18	V <sub>DD</sub>	Positive Power Supply
19	V <sub>OUT</sub>	DAC Voltage Output
20	LOADDAC	The selected DAC register becomes transparent when $\overline{\text{LOADDAC}}$ is LOW. It is in the latched state when $\overline{\text{LOADDAC}}$ is HIGH.
21	RESET	Asynchronous Reset Input. Sets the DAC register to either zero-scale (000 <sub>H</sub> ) or mid-scale (800 <sub>H</sub> ) when LOW. RESETSEL determines which code is active.
22	RESETSEL	When LOW, a LOW on $\overline{\text{RESET}}$ will cause the DAC register to be set to code 000 <sub>H</sub> . When RESETSEL is HIGH, a LOW on $\overline{\text{RESET}}$ will set the registers to code 800 <sub>H</sub> .
23	CS	Chip Select. Active LOW.
24	R/W	Enabled by $\overline{\text{CS}}$ . Controls data read and write from the input register.

# TYPICAL PERFORMANCE CURVES: $V_{SS} = 0V$

At  $T_A = +25^\circ C$ ,  $V_{DD} = +5V$ ,  $V_{REFH} = +2.5V$ , and  $V_{REFL} = 0V$ , representative unit, unless otherwise specified.

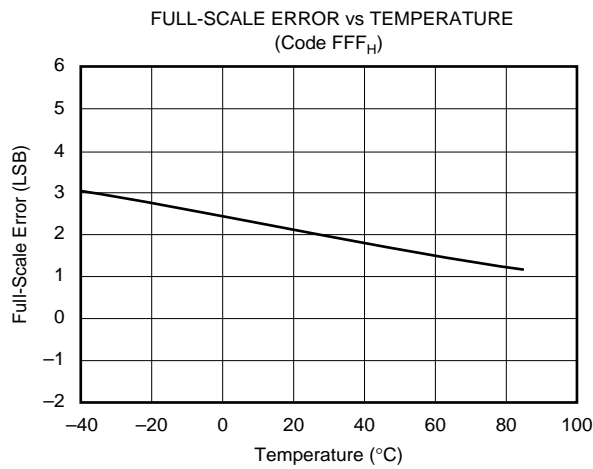
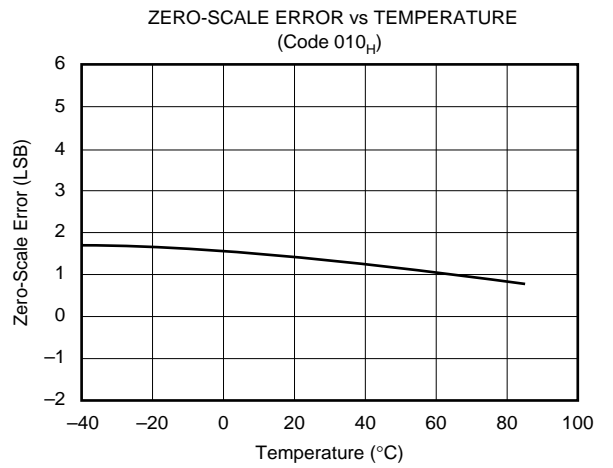
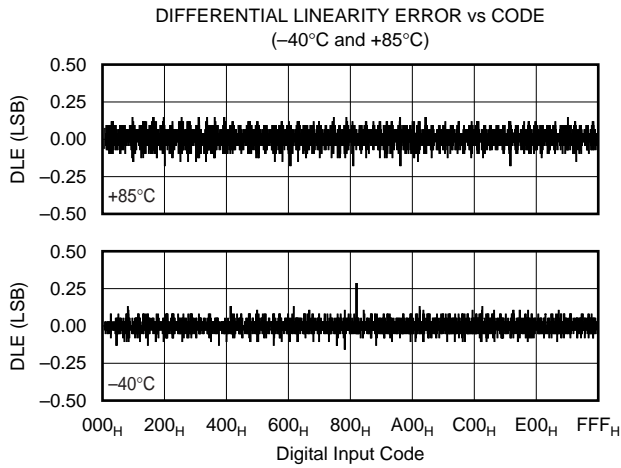
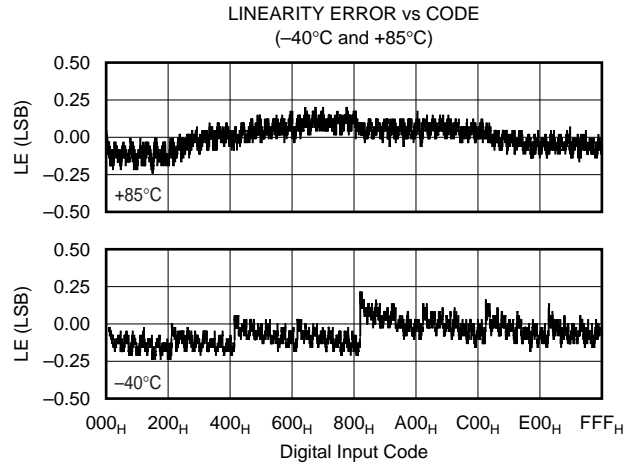
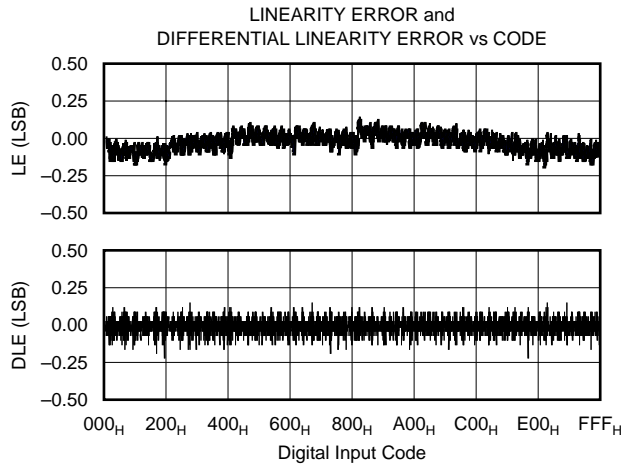

# TYPICAL PERFORMANCE CURVES: $V_{SS} = -5V$

At  $T_A = +25^\circ C$ ,  $V_{DD} = +5V$ ,  $V_{REFH} = +2.5V$ , and  $V_{REFL} = 0V$ , representative unit, unless otherwise specified.

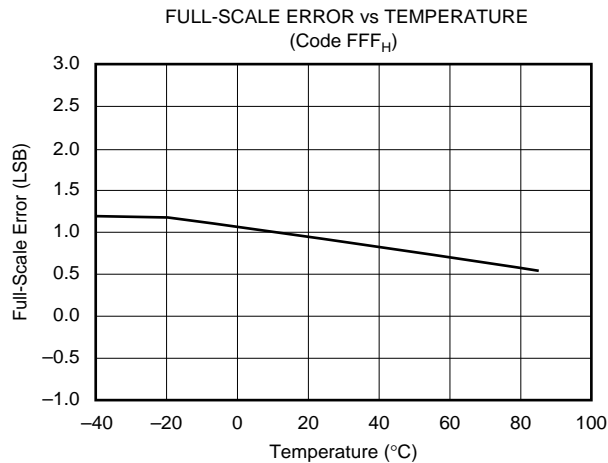
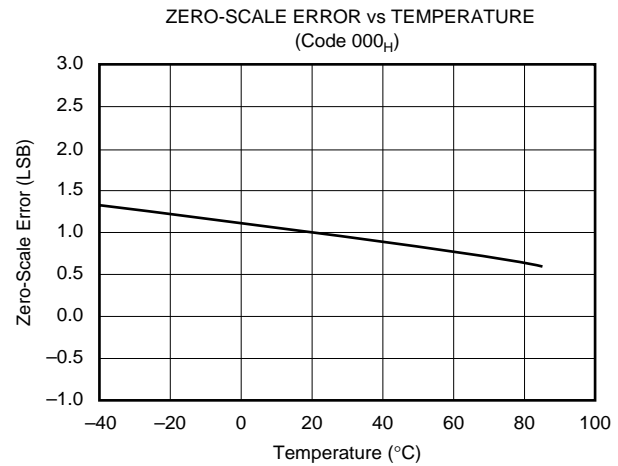
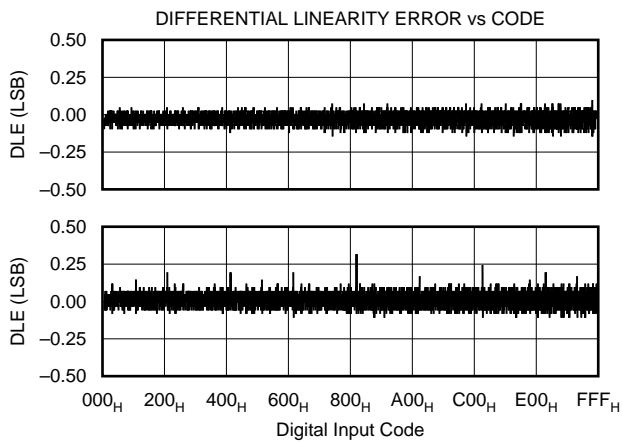
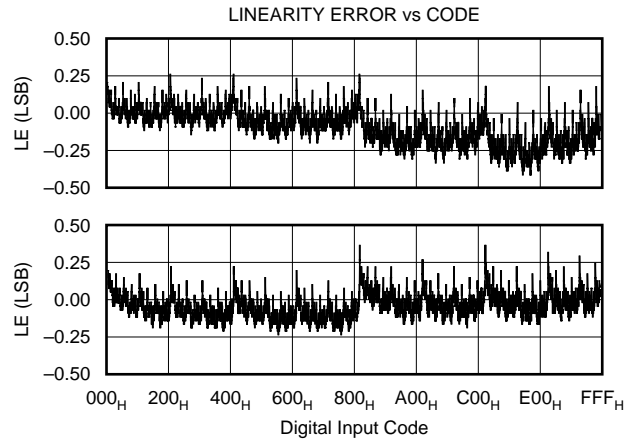
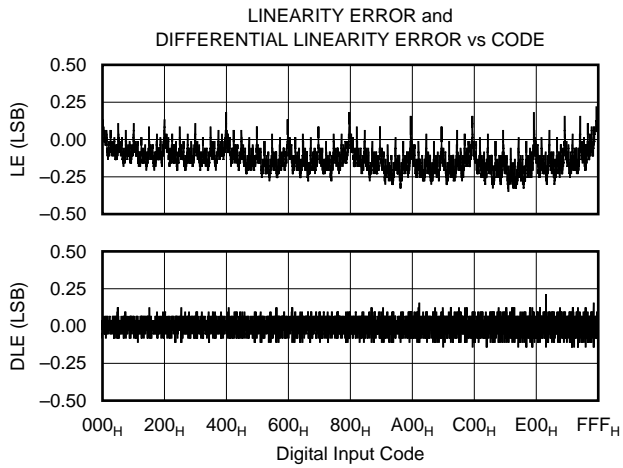

# THEORY OF OPERATION

The DAC7613 is a 12-bit, voltage output Digital-to-Analog Converter (DAC). The architecture is a classic R-2R ladder configuration followed by an operational amplifier that serves as a buffer. The minimum voltage output (“zero-scale”) and maximum voltage output (“full-scale”) are set by the external voltage references ( $V_{REFL}$  and  $V_{REFH}$ , respectively). The digital input is a 12-bit parallel word and the DAC input

register offers a readback capability. The converter can be powered from a single +5V supply or a dual  $\pm 5V$  supply. The device offers a reset function which immediately sets the DAC output voltage and DAC register to mid-scale (code 800<sub>H</sub>) or to zero-scale (code 000<sub>H</sub>), depending on the status of the reset selection. See Figures 1 and 2 for the basic operation of the DAC7613.

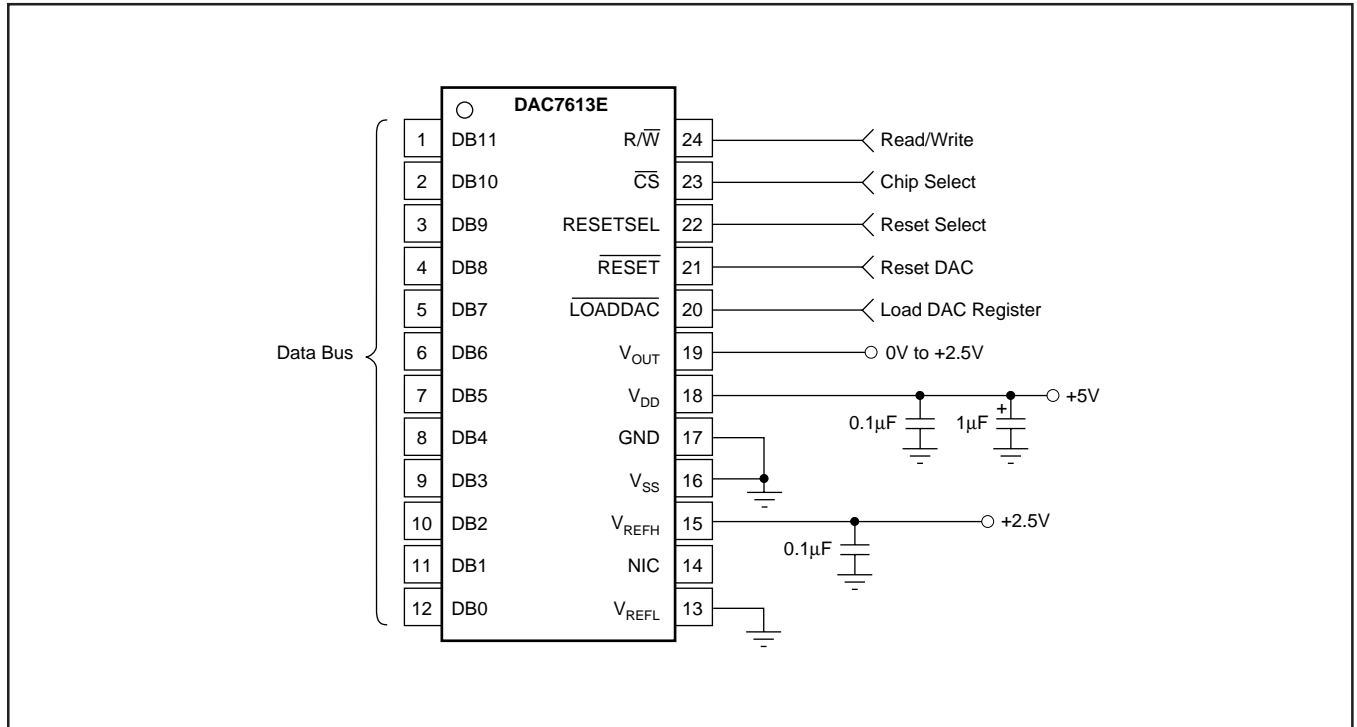

FIGURE 1. Basic Single-Supply Operation of the DAC7613.

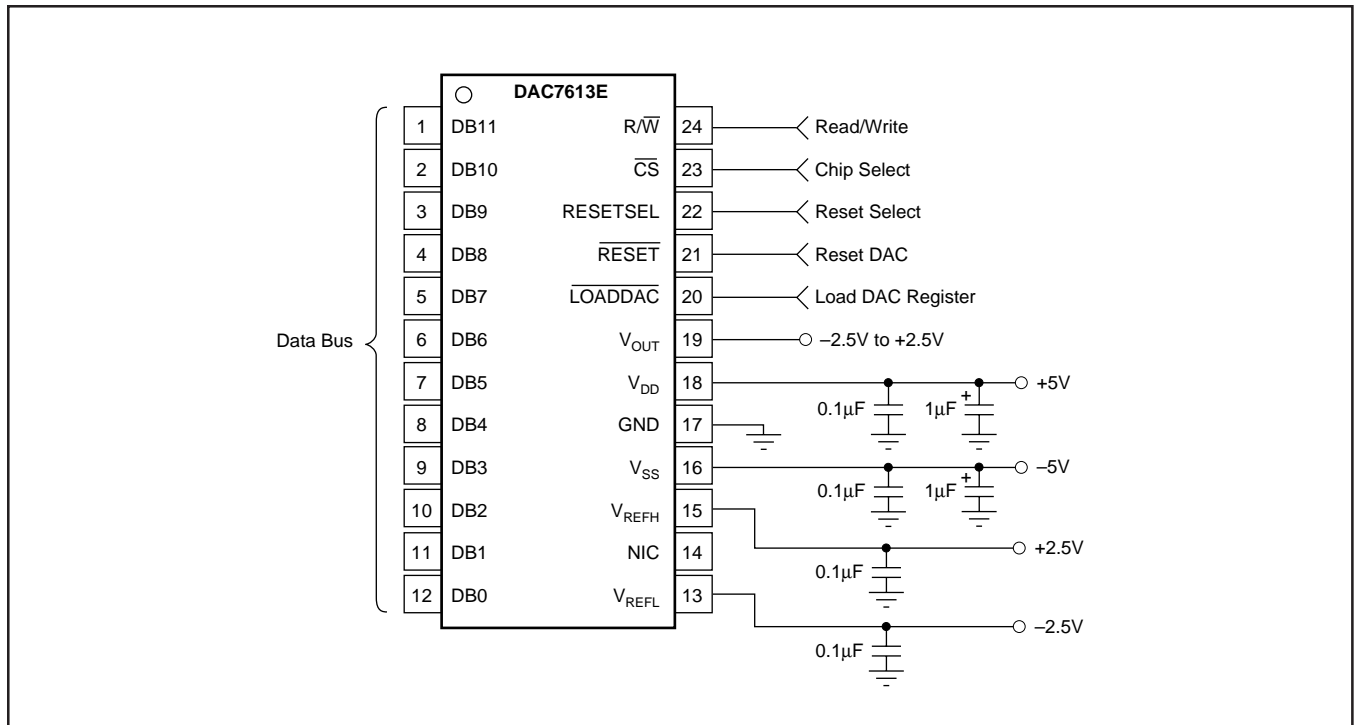

FIGURE 2. Basic Dual-Supply Operation of the DAC7613.

## ANALOG OUTPUTS

When  $V_{SS} = -5V$  (dual supply operation), the output amplifier can swing to within 2.25V of the supply rails, guaranteed over the  $-40^{\circ}C$  to  $+85^{\circ}C$  temperature range. With  $V_{SS} = 0V$  (single-supply operation), the output can swing to ground. Note that the settling time of the output op amp will be longer with voltages very near ground. Additionally, care must be taken when measuring the zero-scale error when  $V_{SS} = 0V$ . Since the output voltage cannot swing below ground, the output voltage may not change for the first few digital input codes (000<sub>H</sub>, 001<sub>H</sub>, 002<sub>H</sub>, etc.) if the output amplifier has a negative offset.

The behavior of the output amplifier can be critical in some applications. Under short-circuit conditions (DAC output shorted to ground), the output amplifier can sink a great deal more current than it can source. See the Specifications table for more details concerning short-circuit current.

## REFERENCE INPUTS

The reference inputs,  $V_{REFL}$  and  $V_{REFH}$ , can be any voltage between  $V_{SS} + 2.25V$  and  $V_{DD} - 2.25V$  provided that  $V_{REFH}$  is at least 1.25V greater than  $V_{REFL}$ . The minimum output of each DAC is equal to  $V_{REFL}$  plus a small offset voltage (essentially, the offset of the output op amp). The maximum output is equal to  $V_{REFH}$  plus a similar offset voltage. Note that  $V_{SS}$  (the negative power supply) must either be connected to ground or must be in the range of  $-4.75V$  to  $-5.25V$ . The voltage on  $V_{SS}$  sets several bias points within the converter. If  $V_{SS}$  is not in one of these two configurations, the bias values may be in error and proper operation of the device is not guaranteed.

The current into the  $V_{REFH}$  input depends on the DAC output voltages and can vary from a few microamps to approximately 0.1 milliamp. The  $V_{REFH}$  source will not be required to sink current, only source it. Bypassing the reference voltage or voltages with at least a 0.1 $\mu F$  capacitor placed as close to the DAC7613 package is strongly recommended.

## DIGITAL INTERFACE

Table I shows the basic control logic for the DAC7613. Note that the internal register is level triggered and not edge triggered. When the appropriate signal is LOW, the register becomes transparent. When this signal is returned HIGH, the digital word currently in the register is latched. The first register (the input register) is triggered via the R/W, and CS inputs. The second register (the DAC register) is transparent when  $\overline{LOADDAC}$  input is pulled LOW.

The double-buffered architecture is mainly designed so that the DAC input register can be written at any time and then the DAC voltage updated by pulling  $\overline{LOADDAC}$  LOW.

R/W	CS	RST	LOADDAC	INPUT REGISTER	DAC REGISTER	MODE
L	L	H	L	Write	Write	Write
L	L	H	H	Write	Hold	Write Input
H	L	H	H	Read	Hold	Read Input
X	H	H	L	Hold	Update	Update
X	H	H	H	Hold	Hold	Hold
X	H	L	X	Hold	Reset	Reset

X = Don't Care.

TABLE I. DAC7613 Control Logic Truth Table.

## DIGITAL TIMING

Figure 3 and Table II provide detailed timing for the digital interface of the DAC7613.

## DIGITAL INPUT CODING

The DAC7613 input data is in Straight Binary format. The output voltage is given by the following equation:

$$V_{OUT} = V_{REFL} + \frac{(V_{REFH} - V_{REFL}) \cdot N}{4096} \quad (1)$$

where N is the digital input code. This equation does not include the effects of offset (zero-scale) or gain (full-scale) errors.

SYMBOL	DESCRIPTION	MIN	TYP	MAX	UNITS
$t_{RCS}$	$\overline{CS}$ LOW for Read	200			ns
$t_{RDS}$	$R/\overline{W}$ HIGH to $\overline{CS}$ LOW	10			ns
$t_{RDH}$	$R/\overline{W}$ HIGH after $\overline{CS}$ HIGH	0			ns
$t_{DZ}$	$\overline{CS}$ HIGH to Data Bus in High Impedance		100		ns
$t_{CSD}$	$\overline{CS}$ LOW to Data Bus Valid		100	160	ns
$t_{WCS}$	$\overline{CS}$ LOW for Write	50			ns
$t_{WS}$	$R/\overline{W}$ LOW to $\overline{CS}$ LOW	0			ns
$t_{WH}$	$R/\overline{W}$ LOW after $\overline{CS}$ HIGH	5			ns
$t_{DS}$	Data Valid to $\overline{CS}$ HIGH	0			ns
$t_{DH}$	Data Valid after $\overline{CS}$ HIGH	5			ns
$t_{LWD}$	$\overline{LOADDAC}$ LOW	50			ns
$t_{RESET}$	RESET LOW	50			ns

TABLE II. Timing Specifications ( $T_A = -40^\circ\text{C}$  to  $+85^\circ\text{C}$ ).

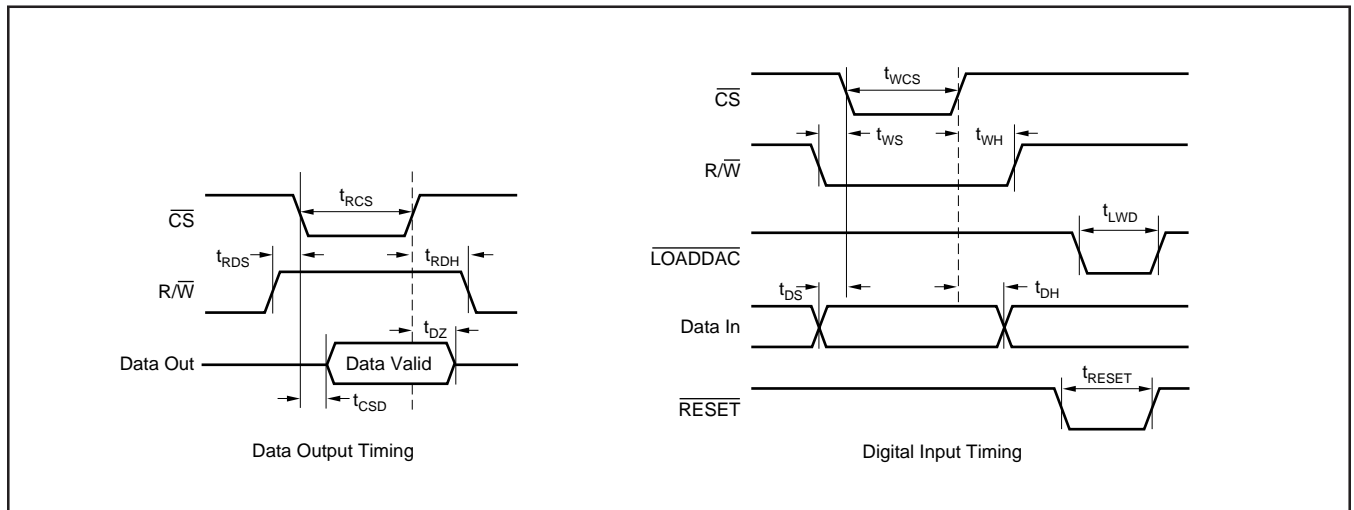

FIGURE 3. Digital Input and Output Timing.

**PACKAGING INFORMATION**

Orderable Device	Status <sup>(1)</sup>	Package Type	Package Drawing	Pins	Package Qty	Eco Plan <sup>(2)</sup>	Lead/Ball Finish	MSL Peak Temp <sup>(3)</sup>
DAC7613E	ACTIVE	SSOP	DB	24	60	Green (RoHS & no Sb/Br)	CU NIPDAU	Level-3-260C-168 HR
DAC7613E/1K	ACTIVE	SSOP	DB	24	1000	Green (RoHS & no Sb/Br)	CU NIPDAU	Level-3-260C-168 HR
DAC7613E/1KG4	ACTIVE	SSOP	DB	24	1000	Green (RoHS & no Sb/Br)	CU NIPDAU	Level-3-260C-168 HR
DAC7613EB	ACTIVE	SSOP	DB	24	60	Green (RoHS & no Sb/Br)	CU NIPDAU	Level-3-260C-168 HR
DAC7613EB/1K	ACTIVE	SSOP	DB	24	1000	Green (RoHS & no Sb/Br)	CU NIPDAU	Level-3-260C-168 HR
DAC7613EB/1KG4	ACTIVE	SSOP	DB	24	1000	Green (RoHS & no Sb/Br)	CU NIPDAU	Level-3-260C-168 HR
DAC7613EBG4	ACTIVE	SSOP	DB	24	60	Green (RoHS & no Sb/Br)	CU NIPDAU	Level-3-260C-168 HR
DAC7613EG4	ACTIVE	SSOP	DB	24	60	Green (RoHS & no Sb/Br)	CU NIPDAU	Level-3-260C-168 HR

<sup>(1)</sup> The marketing status values are defined as follows:

**ACTIVE:** Product device recommended for new designs.

**LIFEBUY:** TI has announced that the device will be discontinued, and a lifetime-buy period is in effect.

**NRND:** Not recommended for new designs. Device is in production to support existing customers, but TI does not recommend using this part in a new design.

**PREVIEW:** Device has been announced but is not in production. Samples may or may not be available.

**OBSOLETE:** TI has discontinued the production of the device.

<sup>(2)</sup> Eco Plan - The planned eco-friendly classification: Pb-Free (RoHS), Pb-Free (RoHS Exempt), or Green (RoHS & no Sb/Br) - please check <http://www.ti.com/productcontent> for the latest availability information and additional product content details.

**TBD:** The Pb-Free/Green conversion plan has not been defined.

**Pb-Free (RoHS):** TI's terms "Lead-Free" or "Pb-Free" mean semiconductor products that are compatible with the current RoHS requirements for all 6 substances, including the requirement that lead not exceed 0.1% by weight in homogeneous materials. Where designed to be soldered at high temperatures, TI Pb-Free products are suitable for use in specified lead-free processes.

**Pb-Free (RoHS Exempt):** This component has a RoHS exemption for either 1) lead-based flip-chip solder bumps used between the die and package, or 2) lead-based die adhesive used between the die and leadframe. The component is otherwise considered Pb-Free (RoHS compatible) as defined above.

**Green (RoHS & no Sb/Br):** TI defines "Green" to mean Pb-Free (RoHS compatible), and free of Bromine (Br) and Antimony (Sb) based flame retardants (Br or Sb do not exceed 0.1% by weight in homogeneous material)

<sup>(3)</sup> MSL, Peak Temp. -- The Moisture Sensitivity Level rating according to the JEDEC industry standard classifications, and peak solder temperature.

**Important Information and Disclaimer:**The information provided on this page represents TI's knowledge and belief as of the date that it is provided. TI bases its knowledge and belief on information provided by third parties, and makes no representation or warranty as to the accuracy of such information. Efforts are underway to better integrate information from third parties. TI has taken and continues to take reasonable steps to provide representative and accurate information but may not have conducted destructive testing or chemical analysis on incoming materials and chemicals. TI and TI suppliers consider certain information to be proprietary, and thus CAS numbers and other limited information may not be available for release.

In no event shall TI's liability arising out of such information exceed the total purchase price of the TI part(s) at issue in this document sold by TI to Customer on an annual basis.

## IMPORTANT NOTICE

Texas Instruments Incorporated and its subsidiaries (TI) reserve the right to make corrections, modifications, enhancements, improvements, and other changes to its products and services at any time and to discontinue any product or service without notice. Customers should obtain the latest relevant information before placing orders and should verify that such information is current and complete. All products are sold subject to TI's terms and conditions of sale supplied at the time of order acknowledgment.

TI warrants performance of its hardware products to the specifications applicable at the time of sale in accordance with TI's standard warranty. Testing and other quality control techniques are used to the extent TI deems necessary to support this warranty. Except where mandated by government requirements, testing of all parameters of each product is not necessarily performed.

TI assumes no liability for applications assistance or customer product design. Customers are responsible for their products and applications using TI components. To minimize the risks associated with customer products and applications, customers should provide adequate design and operating safeguards.

TI does not warrant or represent that any license, either express or implied, is granted under any TI patent right, copyright, mask work right, or other TI intellectual property right relating to any combination, machine, or process in which TI products or services are used. Information published by TI regarding third-party products or services does not constitute a license from TI to use such products or services or a warranty or endorsement thereof. Use of such information may require a license from a third party under the patents or other intellectual property of the third party, or a license from TI under the patents or other intellectual property of TI.

Reproduction of information in TI data books or data sheets is permissible only if reproduction is without alteration and is accompanied by all associated warranties, conditions, limitations, and notices. Reproduction of this information with alteration is an unfair and deceptive business practice. TI is not responsible or liable for such altered documentation.

Resale of TI products or services with statements different from or beyond the parameters stated by TI for that product or service voids all express and any implied warranties for the associated TI product or service and is an unfair and deceptive business practice. TI is not responsible or liable for any such statements.

Following are URLs where you can obtain information on other Texas Instruments products and application solutions:

### Products

Amplifiers	<a href="http://amplifier.ti.com">amplifier.ti.com</a>
Data Converters	<a href="http://dataconverter.ti.com">dataconverter.ti.com</a>
DSP	<a href="http://dsp.ti.com">dsp.ti.com</a>
Interface	<a href="http://interface.ti.com">interface.ti.com</a>
Logic	<a href="http://logic.ti.com">logic.ti.com</a>
Power Mgmt	<a href="http://power.ti.com">power.ti.com</a>
Microcontrollers	<a href="http://microcontroller.ti.com">microcontroller.ti.com</a>
Low Power Wireless	<a href="http://www.ti.com/lpw">www.ti.com/lpw</a>

### Applications

Audio	<a href="http://www.ti.com/audio">www.ti.com/audio</a>
Automotive	<a href="http://www.ti.com/automotive">www.ti.com/automotive</a>
Broadband	<a href="http://www.ti.com/broadband">www.ti.com/broadband</a>
Digital Control	<a href="http://www.ti.com/digitalcontrol">www.ti.com/digitalcontrol</a>
Military	<a href="http://www.ti.com/military">www.ti.com/military</a>
Optical Networking	<a href="http://www.ti.com/opticalnetwork">www.ti.com/opticalnetwork</a>
Security	<a href="http://www.ti.com/security">www.ti.com/security</a>
Telephony	<a href="http://www.ti.com/telephony">www.ti.com/telephony</a>
Video & Imaging	<a href="http://www.ti.com/video">www.ti.com/video</a>
Wireless	<a href="http://www.ti.com/wireless">www.ti.com/wireless</a>

Mailing Address: Texas Instruments  
Post Office Box 655303 Dallas, Texas 75265